

Technology – short and to the point

Special technical features of **maxon EC motors:**

- No mechanical commutation
- Long service life - only limited by bearing
- Without cogging
- High speeds even at low voltages
- The maxon winding technology allows the winding to be optimized for specific applications
- Good heat dissipation, high overload ability
- Mainly linear motor characteristics, excellent control properties
- High efficiency
- Very small electrical time constants and low inductance

The electronically commuted EC motors from maxon are high quality DC motors with neodymium magnets. Unlike maxon DC motors, the iron-less winding ❹ is stationary in this case. Instead, the permanent magnet ❺ turns in the electrically generated rotating field of the three-phase winding.

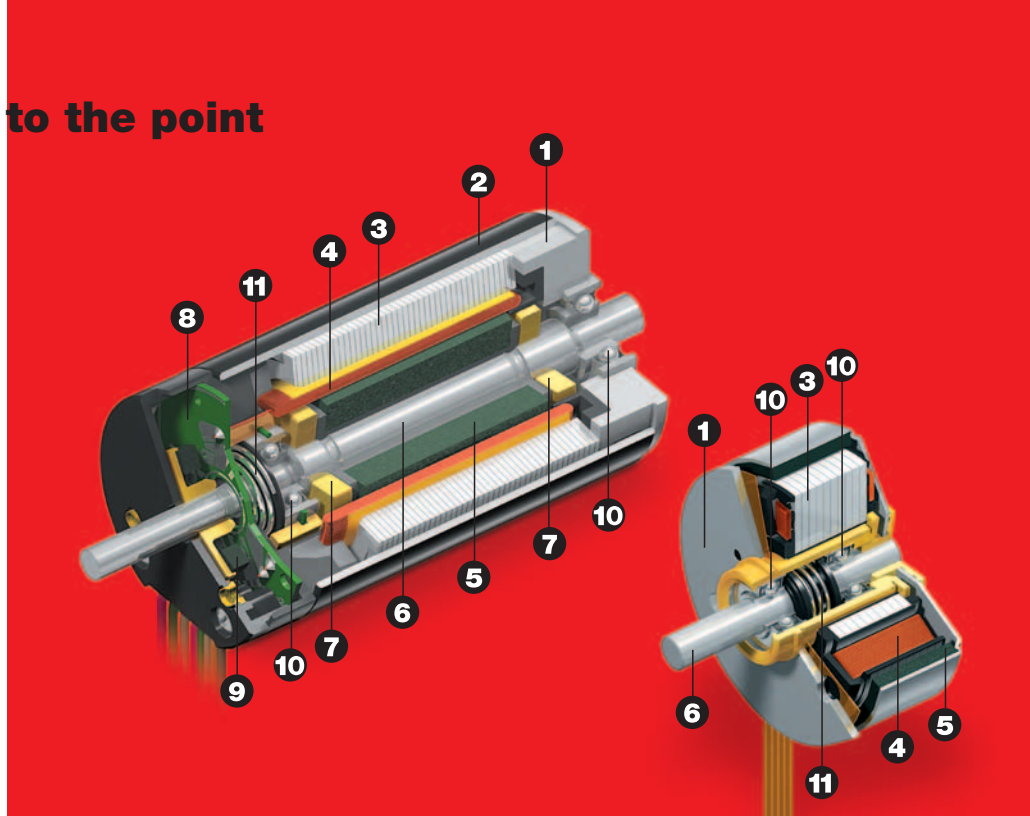

Features of the **maxon EC flat motors:**

- Flat design when space is limited
- Relatively high inertia
- Low detent (winding with iron core)
- Motor gradients that vary from the strongly linear pattern
- Block commutation with and without Hall sensors
- Small commutation steps through high number of poles of the permanent magnetic rotor
- Highly efficient
- Hall sensor signal can be used for simple speed and position measurements
- Combination options with gearheads
- Option of integrating electronics into the motor

Winding arrangement

The maxon rhombic winding is divided into three partial windings, each shifted by 120°. The partial windings can be connected in two different manners - "Y" or "Δ". This changes the speed and torque inversely proportional by the factor $\sqrt{3}$. However, the winding arrangement does not play a decisive role in the selection of the motor. It is important that the motor-specific parameters (speed and torque constants) are line with requirements.

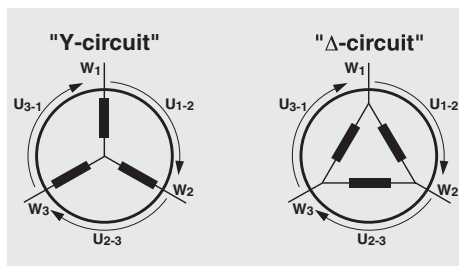

The maximum permissible winding temperature is 125°C. (EC-max to 155°C)

Electronical commutation

Block commutation

Rotor position is reported by three in-built Hall sensors. The Hall sensors arranged offset by 120° provide six different switch combinations per revolution. The three partial windings are now supplied in six different conducting phases in accordance with the sensor information. The current and voltage curves are block-shaped. The switching position of each electronic commutation is offset by 30° from the respective torque maximum.

Properties of block commutation

- Relatively simple and favorably priced electronics
- Torque ripple of 14 %
- Controlled motor start-up
- High starting torques and accelerations possible
- The data of the maxon EC motors are determined with block commutation.

Possible applications

- Highly dynamic servo drives
- Start / stop operation
- Positioning tasks

Hall sensor circuit

Hall sensors do not normally have their own pull-up resistance, as this is integral in maxon controllers. Any exceptions are specifically mentioned in the relevant motor data sheets.

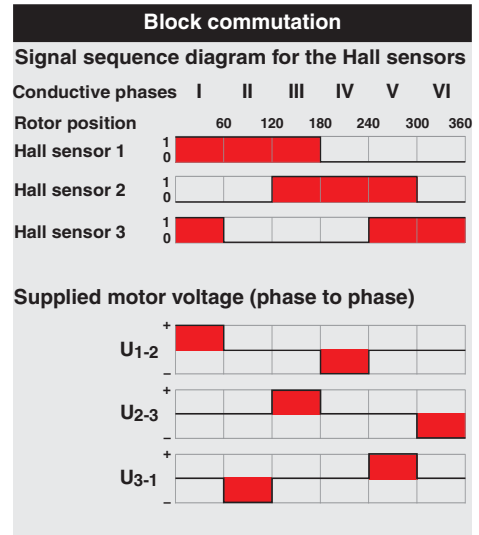
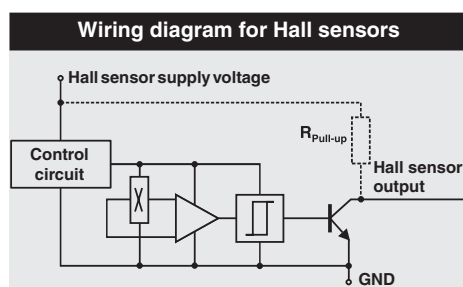

- 1 Flange
- 2 Housing
- 3 Laminated steel stack
- 4 Winding
- 5 Permanent magnet
- 6 Shaft
- 7 Balancing disks
- 8 Print with Hall sensors
- 9 Control magnet
- 10 Ball bearing
- 11 Spring (bearing preload)

Program

maxon EC motor

With Hall sensors

Sensorless

With integrated electronics

EC-Program

EC-max-Program

EC-powermax

EC flat motor

maxon EC motor

Sensorless block commutation

The rotor position is determined using the progression of the induced voltage. The electronics evaluate the zero crossing of the induced voltage (EMF) and commute the motor current after a speed dependent pause (30° after EMF zero crossing).

The amplitude of the induced voltage is dependent on the speed. When stalled or at low speed, the voltage signal is too small and the zero crossing cannot be detected precisely. This is why special algorithms are required for starting (similar to stepper motor control). To allow EC motors to be commuted without sensors in a Δ arrangement, a virtual star point is usually created in the electronics.

Properties of sensorless commutation

- Torque ripple of 14 % (block commutation)
- No defined start-up
- Not suitable for low speeds
- Not suitable for dynamic applications

Possible applications

- Continuous operation at higher speeds
- Fans

Sinusoidal commutation

The high resolution signals from the encoder or resolver are used for generating sine-shape motor currents in the electronics. The currents through the three motor windings are dependent on the rotor position and are shifted at each phase by 120 degrees (sinusoidal commutation). This results in the very smooth, precise running of the motor and, in a very precise, high quality control.

Properties of sinusoidal commutation

- More expensive electronics
- No torque ripple
- Very smooth running, even at very low speeds
- Approx. 5% more continuous torque compared to block commutation

Possible applications

- Highly dynamic servo drives
- Positioning tasks

Bearing

The EC motor only provides real benefits in conjunction with ball bearings. Most maxon EC motors have preloaded ball bearings.

Turning speed

Operating speeds of up to 50 000 rpm are possible. In the case of multi-pole motors the electronics (max. switching frequency) can limit the speed, since more commutation cycles must be run through per motor revolution. The maximum speed is calculated with service life considerations of the ball bearings (20 000 hours) at the maximum permissible residual unbalance of the rotor.

Service life

This is principally limited only by the service life of the bearing. Together with the expected service life of the electronic components used (industrial standards) the EC motor achieves service life of several 10 000 hours.

