

# RE-max 13 Ø13 mm, Precious Metal Brushes CLL, 1.2 Watt

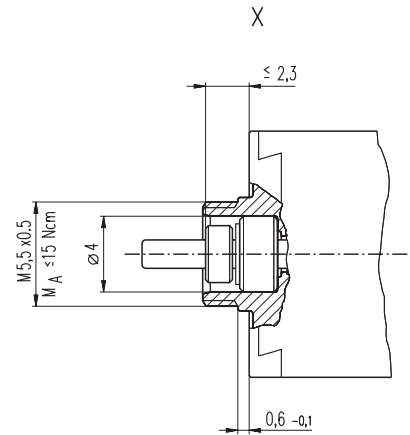
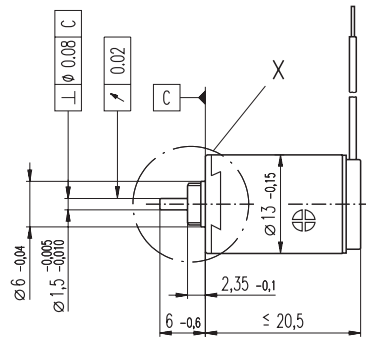
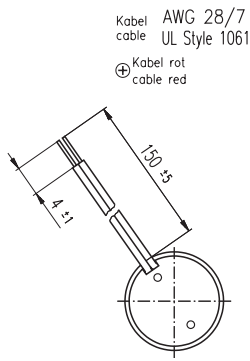

## M 1:1

- Stock program
- Standard program
- Special program (on request)

### Order Number

Motor Data	Order Number															
	201352	203881	203882	203883	203884	203885	203886	203887	203888	203889	203890	203891	203892	203893	203894	
<b>Values at nominal voltage</b>																
1 Nominal voltage	V	1.0	1.2	1.5	1.8	2.4	3.0	3.6	4.2	5.0	6.0	8.0	9.0	10.0	12.0	15.0
2 No load speed	rpm	11600	11400	11200	11100	11400	11700	12200	11600	11400	11100	11800	10700	11200	11400	10800
3 No load current	mA	67.8	54.9	42.8	35.0	27.5	22.7	20.2	16.1	13.1	10.4	8.69	6.65	6.35	5.43	4.01
4 Nominal speed	rpm	10000	9200	8630	7920	7390	7010	7190	6400	6120	5780	6540	5360	5750	5970	5350
5 Nominal torque (max. continuous torque)	mNm	0.335	0.422	0.552	0.682	0.897	1.11	1.28	1.33	1.31	1.32	1.31	1.30	1.28	1.29	1.28
6 Nominal current (max. continuous current)	A	0.480	0.480	0.480	0.480	0.480	0.480	0.480	0.404	0.330	0.267	0.213	0.170	0.158	0.135	0.102
7 Stall torque	mNm	2.42	2.21	2.41	2.41	2.56	2.81	3.14	2.98	2.85	2.78	2.94	2.61	2.67	2.75	2.57
8 Starting current	A	3.02	2.25	1.94	1.59	1.31	1.17	1.14	0.879	0.695	0.548	0.465	0.333	0.318	0.278	0.198
9 Max. efficiency	%	73	72	73	73	74	75	76	75	75	75	75	74	74	75	74
<b>Characteristics</b>																
10 Terminal resistance	Ω	0.331	0.533	0.775	1.13	1.84	2.57	3.17	4.78	7.20	11.0	17.2	27.0	31.4	43.2	75.8
11 Terminal inductance	mH	0.0056	0.0083	0.0135	0.0199	0.0333	0.0501	0.0661	0.0993	0.145	0.223	0.346	0.532	0.607	0.847	1.47
12 Torque constant	mNm / A	0.802	0.980	1.25	1.51	1.96	2.41	2.76	3.39	4.10	5.08	6.33	7.84	8.38	9.89	13.0
13 Speed constant	rpm / V	11900	9740	7650	6300	4870	3970	3460	2820	2330	1880	1510	1220	1140	965	734
14 Speed / torque gradient	rpm / mNm	4920	5300	4760	4710	4570	4240	3960	3980	4090	4050	4100	4190	4280	4220	4280
15 Mechanical time constant	ms	18.4	16.1	14.8	14.2	13.7	13.4	13.1	13.1	13.1	13.0	13.0	13.1	13.1	13.0	13.1
16 Rotor inertia	gcm <sup>2</sup>	0.356	0.290	0.298	0.288	0.287	0.301	0.317	0.313	0.305	0.306	0.303	0.298	0.292	0.295	0.292

### Specifications

- Thermal data**
- 17 Thermal resistance housing-ambient 47.5 K / W
  - 18 Thermal resistance winding-housing 14 K / W
  - 19 Thermal time constant winding 5.08 s
  - 20 Thermal time constant motor 356 s
  - 21 Ambient temperature -20 ... +65°C
  - 22 Max. permissible winding temperature +85°C
- Mechanical data (sleeve bearings)**
- 23 Max. permissible speed 19000 rpm
  - 24 Axial play 0.05 - 0.15 mm
  - 25 Radial play 0.014 mm
  - 26 Max. axial load (dynamic) 0.8 N
  - 27 Max. force for press fits (static) 35 N
  - 28 Max. radial loading, 5 mm from flange 1.4 N

### Operating Range

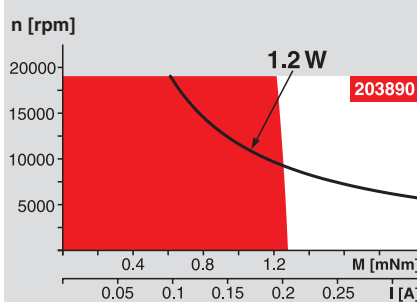

### Comments

- Continuous operation**  
In observation of above listed thermal resistance (lines 17 and 18) the maximum permissible winding temperature will be reached during continuous operation at 25°C ambient.  
= Thermal limit.
- Short term operation**  
The motor may be briefly overloaded (recurring).
- Assigned power rating**

### Other specifications

- 29 Number of pole pairs 1
  - 30 Number of commutator segments 7
  - 31 Weight of motor 15 g
  - CLL = Capacitor Long Life
  - Alignment of the electronic connections not specified.
- Values listed in the table are nominal.  
Explanation of the figures on page 49.

### maxon Modular System

Overview on page 16 - 21

- Planetary Gearhead**  
Ø13 mm  
0.05 - 0.15 Nm  
Page 217
- Planetary Gearhead**  
Ø13 mm  
0.2 - 0.35 Nm  
Page 218

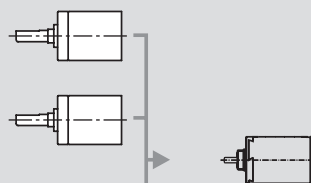

**Recommended Electronics:**  
LSC 30/2 Page 276  
Notes 18