

NOTES (UNLESS OTHERWISE SPECIFIED)

<PARA >1. LINEAR SPECIFICATIONS:

- LINEAR STROKE: 10 mm (5 mm EACH)
- ENC. RESOLUTION(+A/-A;+B/-B): 1, 5  $\mu$ m
- <PARA > ENCODER REPEATABILITY:  $\pm$ 4 COUNTS
- <PARA > OPERATING VOLTAGE: 24 Vdc
- COIL RESISTANCE:  $15.2 \pm 5\%$  Ohm
- MAXIMUM CURRENT 1.6 A
- PEAK FORCE: 1.7 N @ 24Vdc
- FORCE CONSTANT: 1.0 N/A
- MOVING MASS: 3 g
- TOTAL MASS: 42g (W/O CABLE, PIGTAIL CABLE 80g)
- 2. VACUUM OPTION: N/A
- 3. SPRING OPTION: N/A
- 4. OPERATING TEMPERATURE: 0°C TO 40°C
- 5. TOLERANCES

- X.:  $\pm 0.5$
- X.X: 0.25

REVISIONS				
REV	ECR	DESCRIPTION	DATE	APPROVED
A	5978	INITIAL RELEASE	1/11/2017	TW
B	6036	47 WAS 41	3/20/2017	TW

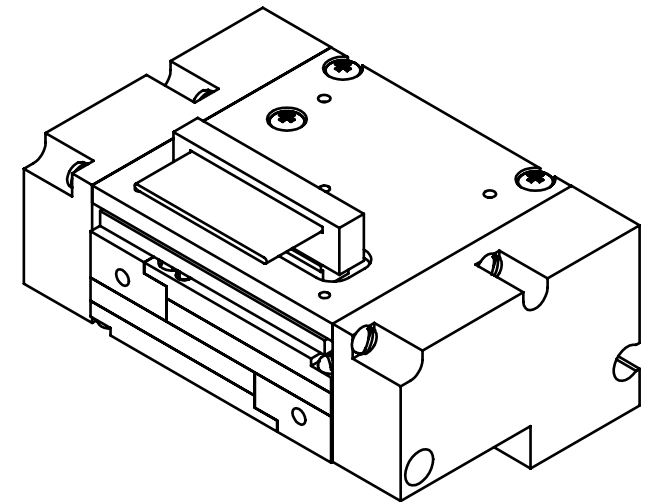
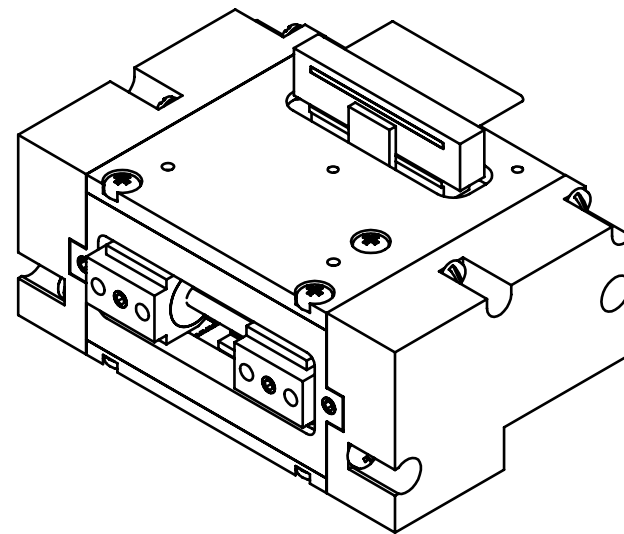
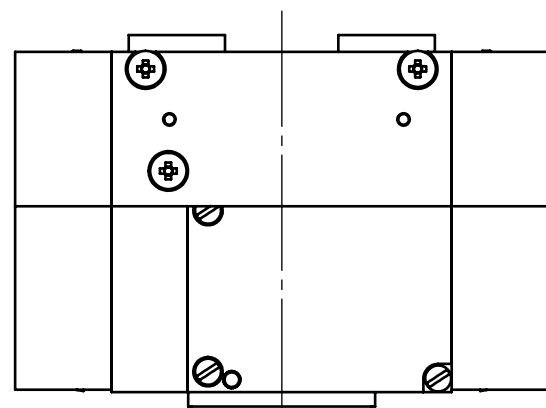
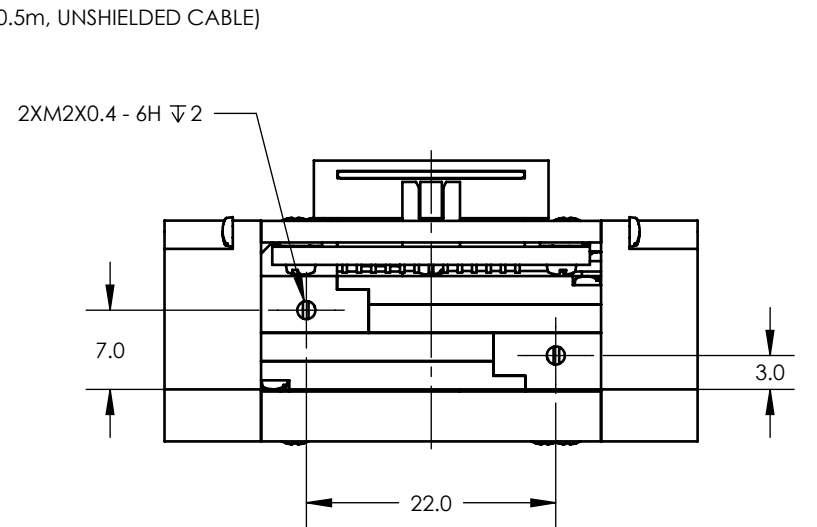
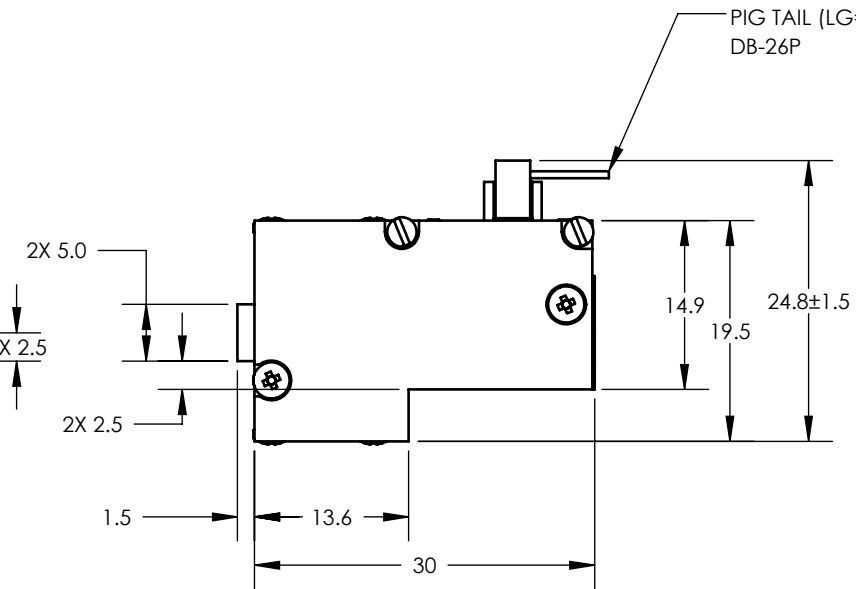
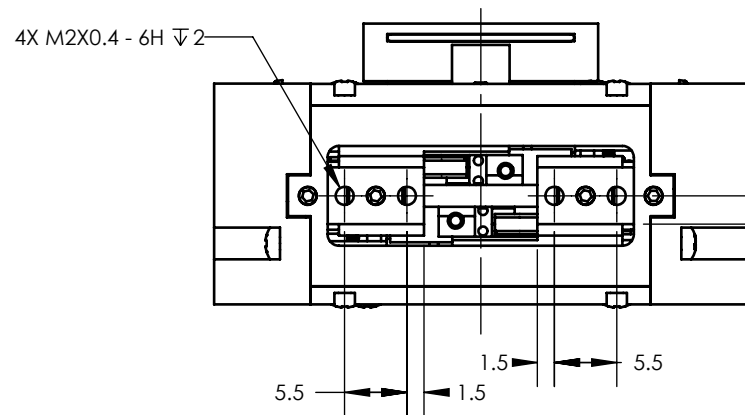
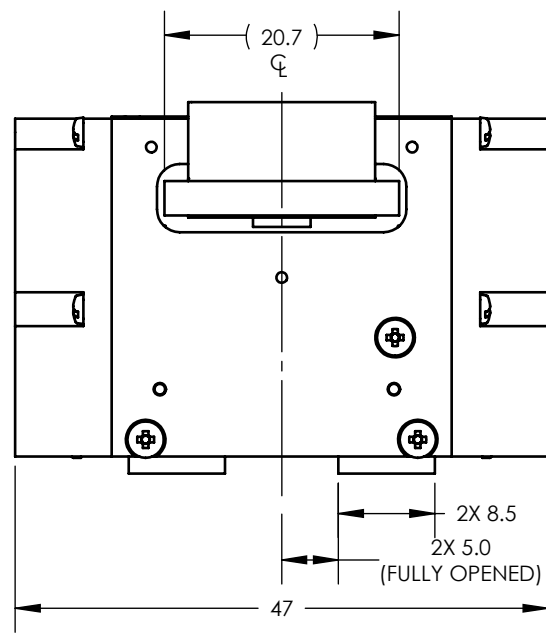

PIN No	DB-26P
1	(AXIS 1) PH. A+
2	(AXIS 1) PH. B+
3	(AXIS 1) PH. Z+
4	NC
5	NC
6	NC
7	(AXIS 2) PH. B+
8	(AXIS 2) PH. A+
9	(AXIS 2) PH. Z+
10	(AXIS 1) PH. A-
11	(AXIS 1) PH. B-
12	(AXIS 1) PH. Z-
13	NC
14	NC
15	NC
16	(AXIS 2) PH. B -
17	(AXIS 2) PH. A -
18	(AXIS 2) PH. Z -
19	+5 VDC
20	5V RTN
21	NC
22	(AXIS 1) COIL +
23	(AXIS 1) COIL -
24	NC
25	(AXIS 2) COIL -
26	(AXIS 2) COIL +

Sold & Serviced By:



Toll Free Phone (877) SERV098

Toll Free Fax (877) SERV099

www.electromate.com  
sales@electromate.com

UNLESS OTHERWISE SPECIFIED ALL DIMENSIONS ARE IN MM BREAK EDGES AND REMOVE BURRS TOLERANCES X.: $\pm 0.5$ X.X: $\pm 0.1$ X.XX: $\pm 0.03$ ANGLE: $\pm 0.1^\circ$ CONCENTRICITY: $\pm 0.025$ ROUNDNESS: $\pm 0.025$ EDGE BREAKS: 0.2 MAX ALL DIMENSIONS AND TOLERANCES ARE FINAL	MATERIAL: SEE BOM	NAME TW	DATE 1/9/2017	<b>SMAC</b> MOVING COIL ACTUATORS 5807 VAN ALLEN WAY CARLSBAD CA, 92008 (760) 929-7588
	FINISH: SEE BOM	DWN BY TW	DATE 1/9/2017	
MACHINE FINISH: SEE BOM	ENG APP TMV	DATE 1/9/2017		TITLE: MGR5-010-5X-1
INTERPRET PER: ASME Y14.5-2009	MFG APP QA APP			SIZE: B PART NO: MGR5-010-5X-1 REV: B
THIRD ANGLE PROJECTION	PROPRIETARY AND CONFIDENTIAL			SCALE: 2:1 DO NOT SCALE SHEET: 1 / 1

REVISIONS				
REV	ECR	DESCRIPTION	DATE	APPROVED
A	6000	INITIAL RELEASE	1/31/2017	TW

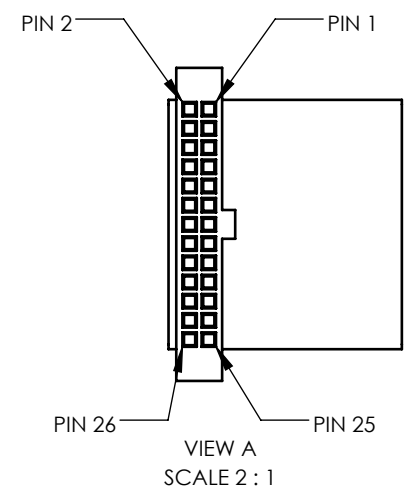
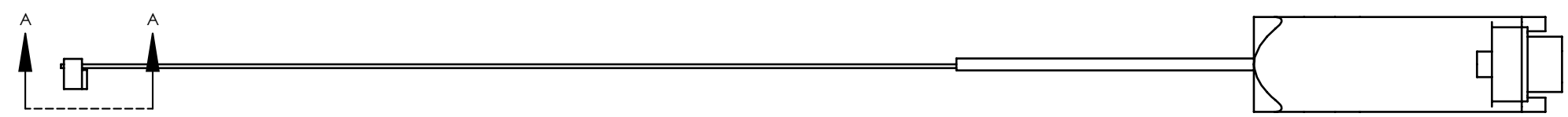
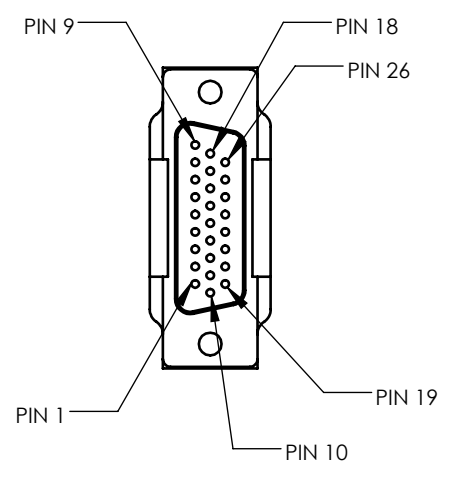
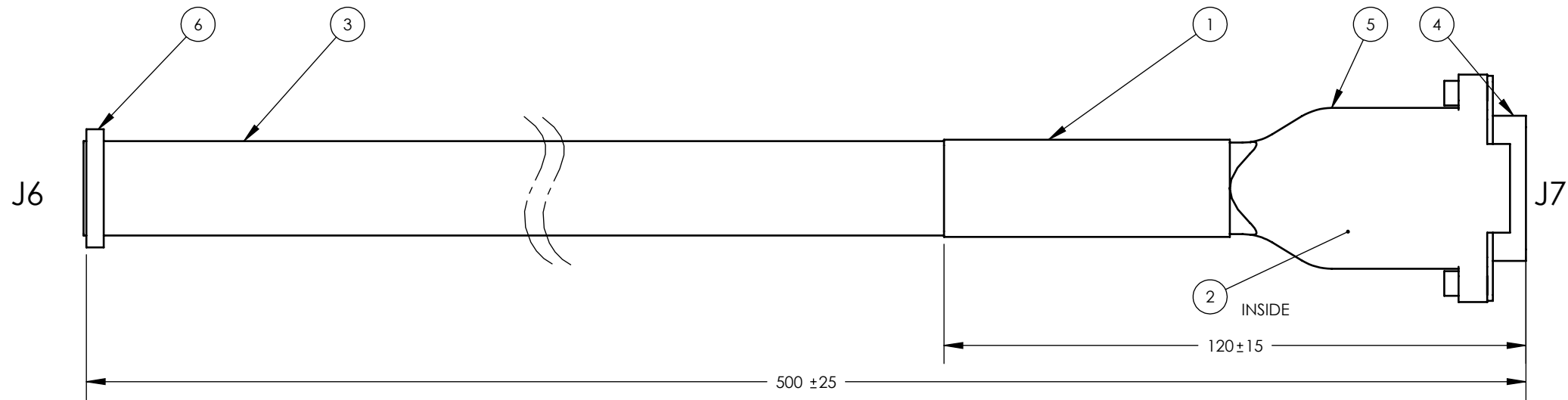

ITEM NO.	PART NUMBER	DESCRIPTION	QTY.
1	44132-00_A_001	SHRINK TUBE 3/8"	1
2	44060-00	SHRINK TUBE 3/64"	1
3	44506-26_A_001	RIBBON CABLE, 26 COND, .025" PITCH	1
4	47014-00_A	CONNECTOR, DB-26	1
5	47015-00_A	CONNECTOR HOOD	1
6	47108-26_A	SOCKET, 26 PIN	1

Sold & Serviced By:  
  
 Toll Free Phone (877) SERV098  
 Toll Free Fax (877) SERV099  
[www.electromate.com](http://www.electromate.com)  
[sales@electromate.com](mailto:sales@electromate.com)

UNLESS OTHERWISE SPECIFIED ALL DIMENSIONS ARE IN MM BREAK EDGES AND REMOVE BURRS TOLERANCES X: ±0.5 X.X: ±0.1 X.XX: ±0.03 ANGLE: ±0.1° CONCENTRICITY: ±0.025 ROUNDNESS: ±0.025 EDGE BREAKS: 0.2 MAX ALL DIMENSIONS AND TOLERANCES ARE FINAL	MATERIAL: SEE BOM	NAME TW	DATE 1/31/2017	<b>SMAC</b> 5807 VAN ALLEN WAY CARLSBAD CA, 92008 (760) 929-7588 <b>MOVING COIL ACTUATORS</b> TITLE: <b>CABLE, PIG TAIL, 0.5M,          MGR5</b> SIZE: B PART NO: <b>LAH-PT26-26</b> SCALE: 1:1 <b>DO NOT SCALE</b> SHEET: 1 / 2
	FINISH: N/A	DWN BY TMV	1/31/2017	
	MACHINE FINISH: 1.6	ENG APP TMV	1/31/2017	
	INTERPRET PER: ASME Y14.5-2009	MFG APP QA APP		
THIRD ANGLE PROJECTION		PROPRIETARY AND CONFIDENTIAL THE INFORMATION CONTAINED IN THIS DRAWING IS THE SOLE PROPERTY OF SMAC. ANY REPRODUCTION IN PART OR AS A WHOLE WITHOUT THE WRITTEN PERMISSION OF SMAC IS PROHIBITED.		

# PIN ASSIGNMENT

## J6

## J7

PIN No	26 P
9	(L)A+
5	(L) B+
10	(L)Z+
22	(R)B+
18	(R)A+
17	(R)Z+
7	(L)A-
6	(L)B-
8	(L)Z-
21	(R)B-
20	(R)A-
19	(R)Z-
12	(L)+5V
11	(L)GND
1	(L)COIL+
2	(L) COIL -
25	(R)COIL-
26	(R)COIL+

PIN No	DB-26P
1	(L) PH. A+
2	(L) PH. B+
3	(L) PH. Z+
4	NC
5	NC
6	NC
7	(R) PH. B+
8	(R) PH. A+
9	(R) PH. Z+
10	(L) PH. A-
11	(L) PH. B-
12	(L) PH. Z-
13	NC
14	NC
15	NC
16	(R) PH. B -
17	(R) PH. A -
18	(R) PH. Z -
19	+5 VDC
20	5V RTN
21	NC
22	(L) COIL+
23	(L) COIL -
24	NC
25	(R) COIL -
26	(R) COIL +

15	(R)+5V
16	(R)GND

JUMPER FOR  
35873-00 REV A

TO 35873-00

Sold & Serviced By:



Toll Free Phone (877) SERV098

Toll Free Fax (877) SERV099

www.electromate.com

sales@electromate.com

**SMAC**  
MOVING COIL ACTUATORS

5807 VAN ALLEN WAY  
CARLSBAD CA, 92008  
(760) 929-7588

TITLE:  
CABLE, PIG TAIL, 0.5M,  
MGR5

SIZE: B PART NO: LAH-PT26-26 REV: A

REF. NUMBER	MGR5-010	SCALE: 1:1	SHEET: 2 / 2
CONTRACT	STD	DO NOT SCALE	