

Description	Power Range
<p>The A12A100 PWM servo drive is designed to drive brush type DC motors at a high switching frequency. A single red/green LED indicates operating status. The drive is fully protected against over-voltage, under-voltage, over-current, over-heating and short-circuits across motor, ground and power leads. Furthermore, the drive can interface with digital controllers or be used stand-alone, and requires only a single unregulated DC power supply. Loop gain, current limit, input gain and offset can be adjusted using 14-turn potentiometers. The offset adjusting potentiometer can also be used as an on-board input signal for testing purposes.</p> <p>See Part Numbering Information on last page of datasheet for additional ordering options.</p>	Peak Current
	12 A
	Continuous Current
	6 A
	Supply Voltage
	20 - 80 VDC



**Features**

- ▲ Four Quadrant Regenerative Operation
- ▲ DIP Switch Selectable Modes
- ▲ DIP Switch Configurable Loop Tuning
- ▲ Selectable Inhibit Logic
- ▲ Adjustable Current Limits
- ▲ High Switching Frequency
- ▲ Differential Input Command
- ▲ Digital Fault Output Monitor
- ▲ On-Board Test Potentiometer
- ▲ Offset Adjustment Potentiometer
- ▲ Adjustable Input Gain
- ▲ Drive Status LED
- ▲ Current Monitor Output
- ▲ Directional Inhibit Inputs for Limit Switches

**MODES OF OPERATION**

- Current
- Voltage
- IR Compensation
- Tachometer Velocity

**COMMAND SOURCE**

- ±10 V Analog

**FEEDBACK SUPPORTED**

- Tachometer (±48 VDC)

**COMPLIANCES & AGENCY APPROVALS**

- UL
- cUL
- CE Class A (LVD)
- CE Class A (EMC)
- RoHS

Sold & Serviced By:



Toll Free Phone (877) SERV098  
 Toll Free Fax (877) SERV099  
[www.electromate.com](http://www.electromate.com)  
[sales@electromate.com](mailto:sales@electromate.com)

**BLOCK DIAGRAM**

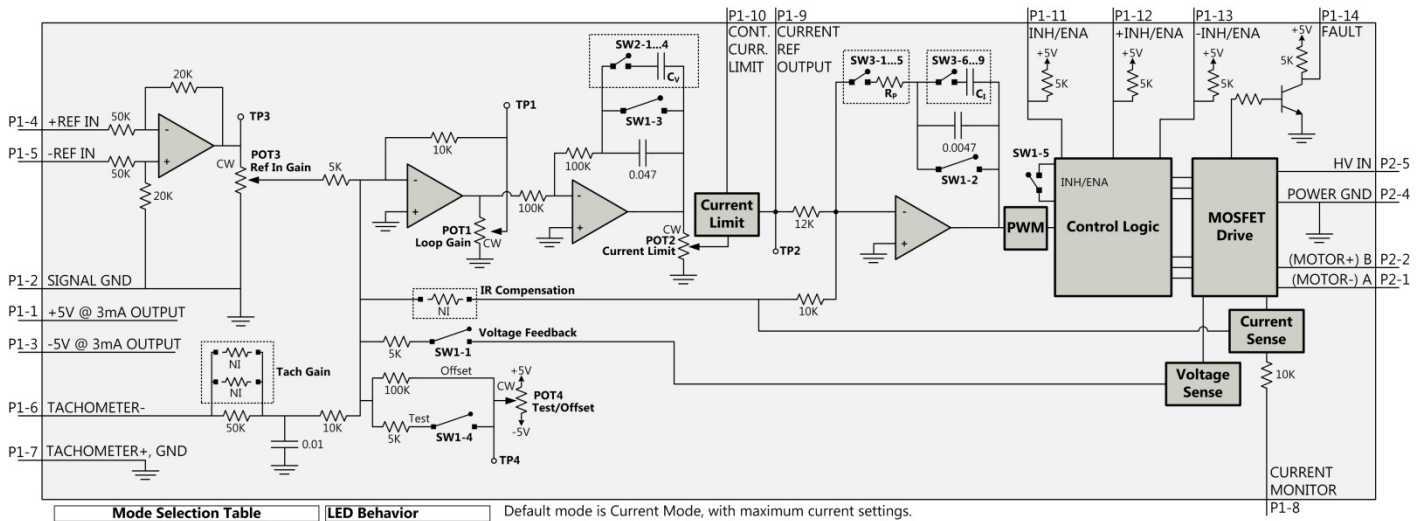



Mode Selection Table		
Mode	SW1-1	SW1-3
Current Mode	OFF	ON
Voltage Mode	ON	OFF
IR Compensation Mode	ON	OFF
Tachometer Mode	OFF	OFF

LED Behavior	
Color	Function
Green	Normal Operation
Red	Fault Condition

Default mode is Current Mode, with maximum current settings.  
Recommended potentiometer setting for Current Mode is:  
Pot 1 = Full CCW, Pot 2 = Full CW, Pot 3 = Full CW.

**Information on Approvals and Compliances**

	<p>US and Canadian safety compliance with UL 508c, the industrial standard for power conversion electronics. UL registered under file number E140173. Note that machine components compliant with UL are considered UL registered as opposed to UL listed as would be the case for commercial products.</p>
	<p>Compliant with European EMC Directive 2004/108/EC on Electromagnetic Compatibility (specifically EN 61000-6-4:2007 for Emissions, Class A and EN 61000-6-2:2005 for Immunity, Performance Criteria A). LVD requirements of Directive 2006/95/EC (specifically, EN 60204-1:2004, a Low Voltage Directive to protect users from electrical shock).</p>
	<p>RoHS (Reduction of Hazardous Substances) is intended to prevent hazardous substances such as lead from being manufactured in electrical and electronic equipment.</p>

Sold & Serviced By:



Toll Free Phone (877) SERV098  
Toll Free Fax (877) SERV099  
www.electromate.com  
sales@electromate.com

**SPECIFICATIONS**

Description		Power Specifications	
		Units	Value
DC Supply Voltage Range		VDC	20 - 80
DC Bus Over Voltage Limit		VDC	88
DC Bus Under Voltage Limit		VDC	15
Maximum Peak Output Current <sup>1</sup>		A	12
Maximum Continuous Output Current		A	6
Maximum Continuous Output Power at Continuous Current		W	456
Maximum Power Dissipation at Continuous Current		W	24
Minimum Load Inductance (Line-To-Line) <sup>2</sup>		μH	200
Internal Bus Capacitance		μF	141
Low Voltage Supply Outputs		-	±5 VDC (3 mA)
Switching Frequency		kHz	38
Description		Control Specifications	
		Units	Value
Command Sources		-	±10 V Analog
Feedback Supported		-	Tachometer (±48 VDC)
Commutation Methods		-	Brush Type
Modes of Operation		-	Current, Voltage, IR Compensation, Tachometer Velocity
Motors Supported		-	Single Phase (Brushed, Voice Coil, Inductive Load)
Hardware Protection		-	Over-Current, Over-Temperature, Over-Voltage, Under-Voltage, Short-Circuit (Phase-Phase & Phase-Ground)
Primary I/O Logic Level		-	5V TTL
Description		Mechanical Specifications	
		Units	Value
Agency Approvals		-	CE Class A (EMC), CE Class A (LVD), cUL, RoHS, UL
Size (H x W x D)		mm (in)	129.3 x 75.8 x 25.1 (5.09 x 2.98 x 0.99)
Weight		g (oz)	249.5 (8.8)
Heatsink (Base) Temperature Range <sup>3</sup>		°C (°F)	0 - 65 (32 - 149)
Storage Temperature Range		°C (°F)	-40 - 85 (-40 - 185)
Form Factor		-	Panel Mount
P1 Connector		-	16-pin, 2.54 mm spaced, friction lock header
P2 Connector		-	5-port, 5.08 mm spaced, quick disconnect terminal

**Notes**

1. Maximum duration of peak current is ~2 seconds. Peak RMS value must not exceed continuous current rating of the drive.
2. Lower inductance is acceptable for bus voltages well below maximum. Use external inductance to meet requirements.
3. Additional cooling and/or heatsink may be required to achieve rated performance.

Sold & Serviced By:



Toll Free Phone (877) SERV098

Toll Free Fax (877) SERV099

[www.electromate.com](http://www.electromate.com)

[sales@electromate.com](mailto:sales@electromate.com)

**PIN FUNCTIONS**

P1 - Signal Connector				
Pin	Name	Description / Notes	I/O	
1	+5V 3mA OUT	±5 V @ 3 mA low power supply for customer use. Short circuit protected. Reference ground common with signal ground.	O	
2	SIGNAL GND		GND	
3	-5V 3mA OUT		O	
4	+REF IN	Differential Reference Input (±10 V Operating Range, ±15 V Maximum Input)	I	
5	-REF IN		I	
6	-TACH IN	Negative Tachometer Input (Maximum ±48 V). Use signal ground for positive input.	I	
7	+TACH / GND	Positive Tachometer Input and Signal Ground	GND	
8	CURRENT MONITOR	Current Monitor. Analog output signal proportional to the actual current output. Scaling is 2.0 A/V. Measure relative to signal ground.	O	
9	CURR REF OUT	Measures the command signal to the internal current-loop. This pin has a maximum output of ±7.25 V when the drive outputs maximum peak current. Measure relative to signal ground.	O	
10	CONT CURRENT LIMIT	Can be used to reduce the factory-preset maximum continuous current limit without affecting the peak current limit by attaching an external current limiting resistor between this pin and signal ground. See pin details for resistor values.	I	
11	INHIBIT / ENABLE	TTL level (+5 V) inhibit/enable input. Pull to ground to inhibit drive (SW1-5 ON). Pull to ground to enable drive (SW1-5 OFF). Inhibit turns off all power devices.	I	
12	+INHIBIT / ENABLE	Positive Direction Inhibit (Does Not Cause A Fault Condition). Pull to ground to inhibit positive direction (SW1-5 ON). Pull to ground to enable positive direction (SW1-5 OFF).	I	
13	-INHIBIT / ENABLE	Negative Direction Inhibit (Does Not Cause A Fault Condition). Pull to ground to inhibit negative direction (SW1-5 ON). Pull to ground to enable negative direction (SW1-5 OFF).	I	
14	FAULT OUT	TTL level (+5 V) output becomes high when power devices are disabled due to at least one of the following conditions: inhibit, output short circuit, over voltage, over temperature, power-up reset.	O	
15	NC	Not Connected (Reserved)	-	
16	NC	Not Connected (Reserved)	-	

P2 - Power Connector				
Pin	Name	Description / Notes	I/O	
1	A	Negative Motor Output	O	
2	B	Positive Motor Output	O	
3	C	Not connected	-	
4	POWER GND	Power Ground (Common With Signal Ground)	PGND	
5	HIGH VOLTAGE	DC Power Input	I	

**Pin Details**

*CONT CURRENT LIMIT (P1-10)*

This pin can be used to reduce the continuous current limit without affecting the peak current limit by connecting an external current limiting resistor between this pin and signal ground. See table below.

Current Limit Resistor	15 kΩ	6.6 kΩ	3.4 kΩ	2.1 kΩ	1.2 kΩ	810Ω	500 Ω	250 Ω	0 kΩ
Continuous Current Limit	90%	80%	70%	60%	50%	40%	30%	20%	10%

Sold & Serviced By:



Toll Free Phone (877) SERV098  
 Toll Free Fax (877) SERV099  
[www.electromate.com](http://www.electromate.com)  
[sales@electromate.com](mailto:sales@electromate.com)

**HARDWARE SETTINGS**

**Configuration Switch Functions**

SW1	Description	Setting	
		On	Off
1	Voltage feedback. Mode dependent (see Mode Selection Table). OFF by default.	On	Off
2	Current loop integral gain. Activates or deactivates integration. Must be OFF if using SW3-6...9 for current loop integral gain tuning purposes. OFF by default.	Inactive	Active
3	Outer loop integration. Activates or deactivates integration. ON for current mode and OFF for other modes. Must be OFF if using SW2 for outer loop. ON by default.	Inactive	Active
4	Test/Offset. Switches the function of the Test/Offset pot between an on-board command input for testing or a command offset adjustment. OFF by default.	Test	Offset
5	Inhibit logic. Sets the logic level of inhibit pins. ON by default.	Drive Inhibit is active low	Drive Inhibit is active high
6	<b>Leave in the ON position for standard operation.</b>	Standard	-

*Mode Selection Table*

	SW1-1	SW1-3	Tachometer
CURRENT	OFF	ON	Not Connected
VOLTAGE	ON	OFF	Not Connected
IR COMPENSATION	ON	OFF	Not Connected
TACHOMETER	OFF	OFF	Connected

**Additional Components†**

*Tachometer Gain*

Some applications may require an increase in the gain of the tachometer input signal. This occurrence will be most common in designs where the tachometer input has a low voltage to RPM scaling ratio. The drive offers two SMT locations where a resistor can be added to increase the tachometer gain. Contact the factory for assistance and instructions before modifying the drive.

*IR Compensation Mode*

For applications that will use IR Compensation mode, a resistor must be added to an SMT location on the PCB. The combination of the added resistor and correct DIP switch settings will configure the amplifier for IR Compensation mode. While in IR Compensation mode, the drive will adjust the duty cycle to compensate for changes in the output current. Contact the factory for assistance and instructions before modifying the drive.

**†Note: Damage done to the drive while performing these modifications will void the warranty.**

**Potentiometer Functions**

Potentiometer	Description	Turning CW
1	Loop gain adjustment for voltage / velocity modes. Turn this pot fully CCW in current mode.	Increases gain
2	Current limit. It adjusts both continuous and peak current limit while maintaining their ratio.	Increases limit
3	Reference gain. Adjusts the ratio between input signal and output variables (voltage, current, or velocity).	Increases gain
4	Offset / Test. Used to adjust any imbalance in the input signal or in the drive. Can also be used as an on-board signal source for testing purposes.	Adjusts offset in negative direction

Note: Potentiometers are approximately linear and have 12 active turns with 1 inactive turn on each end. Test points are provided on the drive PCB near each potentiometer to measure the potentiometer value.

Sold & Serviced By:



Toll Free Phone (877) SERV098  
 Toll Free Fax (877) SERV099  
[www.electromate.com](http://www.electromate.com)  
[sales@electromate.com](mailto:sales@electromate.com)

**Loop Tuning Switch Functions**

In general, the drive will not need to be further tuned beyond the default configuration. However, for applications requiring more precise tuning, DIP switches can be used to adjust the current and velocity loop tuning values. Some general rules of thumb to follow when tuning the drive are:

- A larger resistor value will increase the proportional gain, and therefore create a faster response time.
- A larger capacitor value will increase the integration time, and therefore create a slower response time.

Proper tuning will require careful observation of the loop response on a digital oscilloscope to find optimal DIP switch settings for the specific application.

**(Note: Drive cover must be removed to access SW2 and SW3)**

SW2 DIP switches 1-4 add additional parallel capacitance to the outer loop integrator capacitor (see Block Diagram). The resulting outer loop capacitance values are given in the table below along with the appropriate DIP switch settings. By default, all SW2 switches are OFF (shaded in the SW2 table below).

<b>SW2</b>																
Switch	Outer Loop Integrator Capacitance Options (μF)															
	.047	.147	.267	.367	.517	.617	.737	.837	1.047	1.147	1.267	1.367	1.517	1.617	1.737	1.837
SW2-1	OFF	ON	OFF	ON	OFF	ON	OFF	ON	OFF	ON	OFF	ON	OFF	ON	OFF	ON
SW2-2	OFF	OFF	ON	ON	OFF	OFF	ON	ON	OFF	OFF	ON	ON	OFF	OFF	ON	ON
SW2-3	OFF	OFF	OFF	OFF	ON	ON	ON	ON	OFF	OFF	OFF	OFF	ON	ON	ON	ON
SW2-4	OFF	OFF	OFF	OFF	OFF	OFF	OFF	OFF	ON	ON	ON	ON	ON	ON	ON	ON

Note: The outer loop integrator capacitor can be shorted entirely by setting SW1-3 to OFF.

SW3 DIP switches add additional resistance and capacitance to the current loop tuning circuitry. SW3 switches 1-5 add additional series resistance to the current loop gain resistor, and SW3 switches 6-9 add additional parallel capacitance to the current loop integrator capacitor (see Block Diagram). The resulting capacitance and resistance values are given in the tables below along with the appropriate DIP switch settings. The default switch settings are shaded in the SW3 tables below.

<b>SW3</b>																
Switch	Current Loop Proportional Gain Resistance Options (kΩ)															
	10	20	30	40	50	60	70	80	90	100	110	120	130	140	150	160
SW3-1	ON	OFF	ON	OFF	ON	OFF	ON	OFF	ON	OFF	ON	OFF	ON	OFF	ON	OFF
SW3-2	ON	ON	OFF	OFF	ON	ON	OFF	OFF	ON	ON	OFF	OFF	ON	ON	OFF	OFF
SW3-3	ON	ON	ON	ON	OFF	OFF	OFF	OFF	ON	ON	ON	ON	OFF	OFF	OFF	OFF
SW3-4	ON	ON	ON	ON	ON	ON	ON	ON	ON	OFF	OFF	OFF	OFF	OFF	OFF	OFF
SW3-5	ON	ON	ON	ON	ON	ON	ON	ON	ON	ON	ON	ON	ON	ON	ON	ON
Switch (continued)	170	180	190	200	210	220	230	240	250	260	270	280	290	300	310	320
SW3-1	ON	OFF	ON	OFF	ON	OFF	ON	OFF	ON	OFF	ON	OFF	ON	OFF	ON	OFF
SW3-2	ON	ON	OFF	OFF	ON	ON	OFF	OFF	ON	ON	OFF	OFF	ON	ON	OFF	OFF
SW3-3	ON	ON	ON	ON	OFF	OFF	OFF	OFF	ON	ON	ON	ON	OFF	OFF	OFF	OFF
SW3-4	ON	ON	ON	ON	ON	ON	ON	ON	ON	OFF	OFF	OFF	OFF	OFF	OFF	OFF
SW3-5	OFF	OFF	OFF	OFF	OFF	OFF	OFF	OFF	OFF	OFF	OFF	OFF	OFF	OFF	OFF	OFF

<b>SW3</b>																
Switch	Current Loop Integrator Capacitance Options (μF)															
	.0047	.0094	.0247	.0294	.0517	.0564	.0717	.0764	.0987	.1034	.1187	.1234	.1457	.1504	.1647	.1694
SW3-6	OFF	ON	OFF	ON	OFF	ON	OFF	ON	OFF	ON	OFF	ON	OFF	ON	OFF	ON
SW3-7	OFF	OFF	ON	ON	OFF	OFF	ON	ON	OFF	OFF	ON	ON	OFF	OFF	ON	ON
SW3-8	OFF	OFF	OFF	OFF	ON	ON	ON	ON	OFF	OFF	OFF	OFF	ON	ON	ON	ON
SW3-9	OFF	OFF	OFF	OFF	OFF	OFF	OFF	OFF	ON	ON	ON	ON	ON	ON	ON	ON
SW3-10	SW3-10 should be left OFF at all times															

Note: The current loop integrator capacitor can be shorted entirely by setting SW1-2 to OFF.

**MECHANICAL INFORMATION**

**P1 - Signal Connector**

Connector Information		16-pin, 2.54 mm spaced, friction lock header
Mating Connector	Details	Molex: P/N 22-01-3167 (connector) and P/N 08-50-0114 (insert terminals)
	Included with Drive	Yes

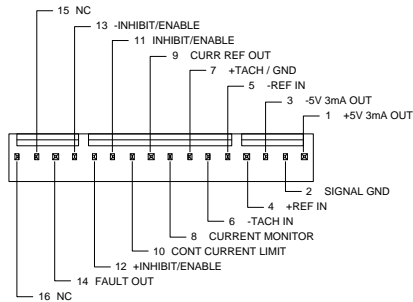

**P2 - Power Connector**

Connector Information		5-port, 5.08 mm spaced, quick-disconnect terminal
Mating Connector	Details	Phoenix: P/N 1911994
	Included with Drive	Yes

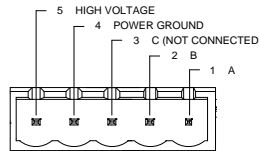

Sold & Serviced By:



Toll Free Phone (877) SERV098

Toll Free Fax (877) SERV099

www.electromate.com

sales@electromate.com

**MOUNTING DIMENSIONS**

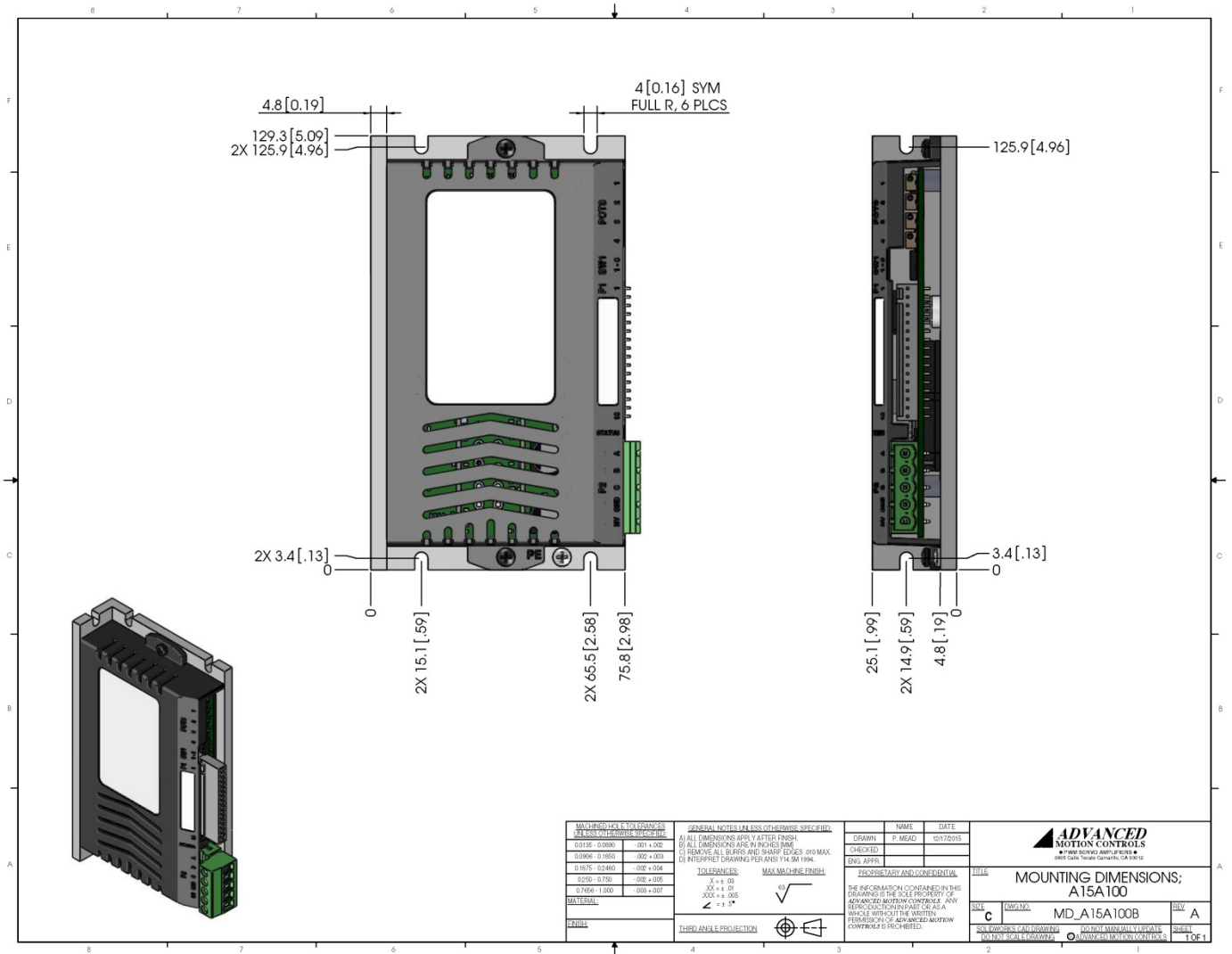

<b>MAXIMUM ALLOWABLE TOLERANCES</b> PER ASME Y14.5-2009		<b>GENERAL NOTES: ALL DIMENSIONS UNLESS OTHERWISE SPECIFIED:</b>		DRAWN: P. MEAD CHECKED: ENG. APPR.:			
0.015: 0.000	-.011 +.002	(A) ALL DIMENSIONS ARE IN INCHES UNLESS OTHERWISE SPECIFIED	(B) ALL DIMENSIONS ARE IN INCHES UNLESS OTHERWISE SPECIFIED	(C) FINISH ALL BLIND AND SHARP EDGES .010 MAX.	(D) INTERPRET DRAWINGS PER ANSI Y14.3M 1994.	<b>TITILE</b> MOUNTING DIMENSIONS; A15A100	
0.0004: 0.0000	-.002 +.003	<b>TOLERANCES:</b> XX +.00 YY +.01 ZZ +.005 AA ±.004		<b>MAX. MACHINE FINISH:</b> 		<b>PROPERTY AND CONFIDENTIAL</b>	
0.0016: 0.0040	-.005 +.004	<b>THE INFORMATION CONTAINED IN THIS DRAWING IS THE SOLE PROPERTY OF ADVANCED MOTION CONTROLS. ANY REPRODUCTION OR DISTRIBUTION OF THIS DRAWING WITHOUT THE WRITTEN PERMISSION OF ADVANCED MOTION CONTROLS IS PROHIBITED.</b>		<b>SIZE</b> C		<b>DWG. NO.</b> MD_A15A100B	
0.005: 0.075	-.002 +.005	<b>THIRD ANGLE PROJECTION</b> 		<b>DATE</b> 10/12/2016		<b>REV</b> A	
0.0069: 1.000	-.009 +.007	<b>MATERIAL</b>		<b>DATE</b> 10/12/2016		<b>REV</b> A	

Sold & Serviced By:



Toll Free Phone (877) SERV098

Toll Free Fax (877) SERV099

www.electromate.com

sales@electromate.com



**PART NUMBERING INFORMATION**

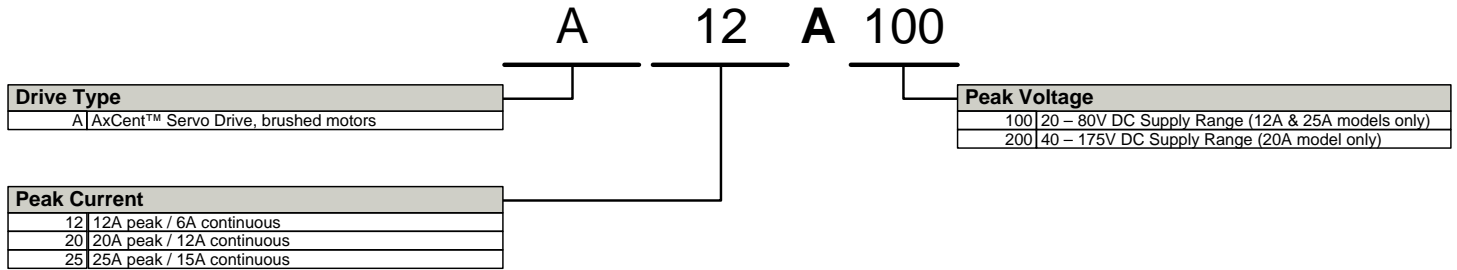

ADVANCED Motion Controls' AxCent™ series of servo drives are available in many configurations. Note that not all possible part number combinations are offered as standard drives. All models listed in the selection tables of the website are readily available, standard product offerings.

ADVANCED Motion Controls also has the capability to promptly develop and deliver specified products for OEMs with volume requests. Our Applications and Engineering Departments will work closely with your design team through all stages of development in order to provide the best servo drive solution for your system. Equipped with on-site manufacturing for quick-turn customs capabilities, ADVANCED Motion Controls utilizes our years of engineering and manufacturing expertise to decrease your costs and time-to-market while increasing system quality and reliability.

**Examples of Modifications and Customized Products**

- |   |  |
|---|--|
| <ul style="list-style-type: none"> <li>▲ Integration of Drive into Motor Housing</li> <li>▲ Mount OEM PCB onto Drive Without Cables</li> <li>▲ Multi-axis Configuration for Compact System</li> <li>▲ Custom PCB and Baseplate for Optimized Footprint</li> <li>▲ RTV/Epoxy Components for High Vibration</li> <li>▲ OEM Specified Connectors for Instant Compatibility</li> <li>▲ OEM Specified Silkscreen for Custom Appearance</li> <li>▲ Increased Thermal Limits for High Temp. Operation</li> </ul> | <ul style="list-style-type: none"> <li>▲ Integrate OEM Circuitry onto Drive PCB</li> <li>▲ Custom Control Loop Tuned to Motor Characteristics</li> <li>▲ Custom I/O Interface for System Compatibility</li> <li>▲ Preset Switches and Pots to Reduce User Setup</li> <li>▲ Optimized Switching Frequency</li> <li>▲ Ramped Velocity Command for Smooth Acceleration</li> <li>▲ Remove Unused Features to Reduce OEM Cost</li> <li>▲ Application Specific Current and Voltage Limits</li> </ul> |
|---|--|

Feel free to contact Applications Engineering for further information and details.

**Available Accessories**

ADVANCED Motion Controls offers a variety of accessories designed to facilitate drive integration into a servo system. Visit [www.a-m-c.com](http://www.a-m-c.com) to see which accessories will assist with your application design and implementation.

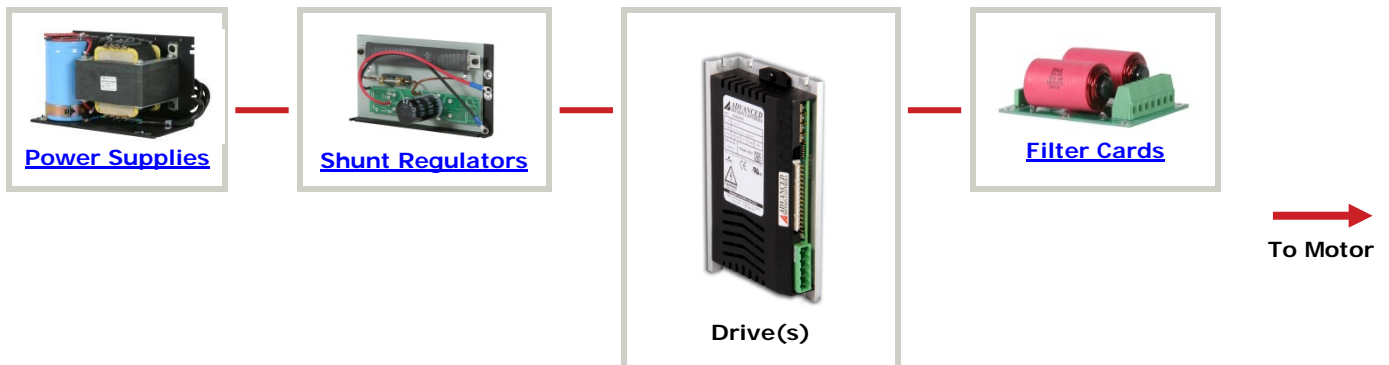

Sold & Serviced By:



Toll Free Phone (877) SERV098

Toll Free Fax (877) SERV099

[www.electromate.com](http://www.electromate.com)

[sales@electromate.com](mailto:sales@electromate.com)