

Sold & Serviced By:

 **ELECTROMATE**

Toll Free Phone (877) SERV098

Toll Free Fax (877) SERV099

www.electromate.com

sales@electromate.com

Bell  **Everman**

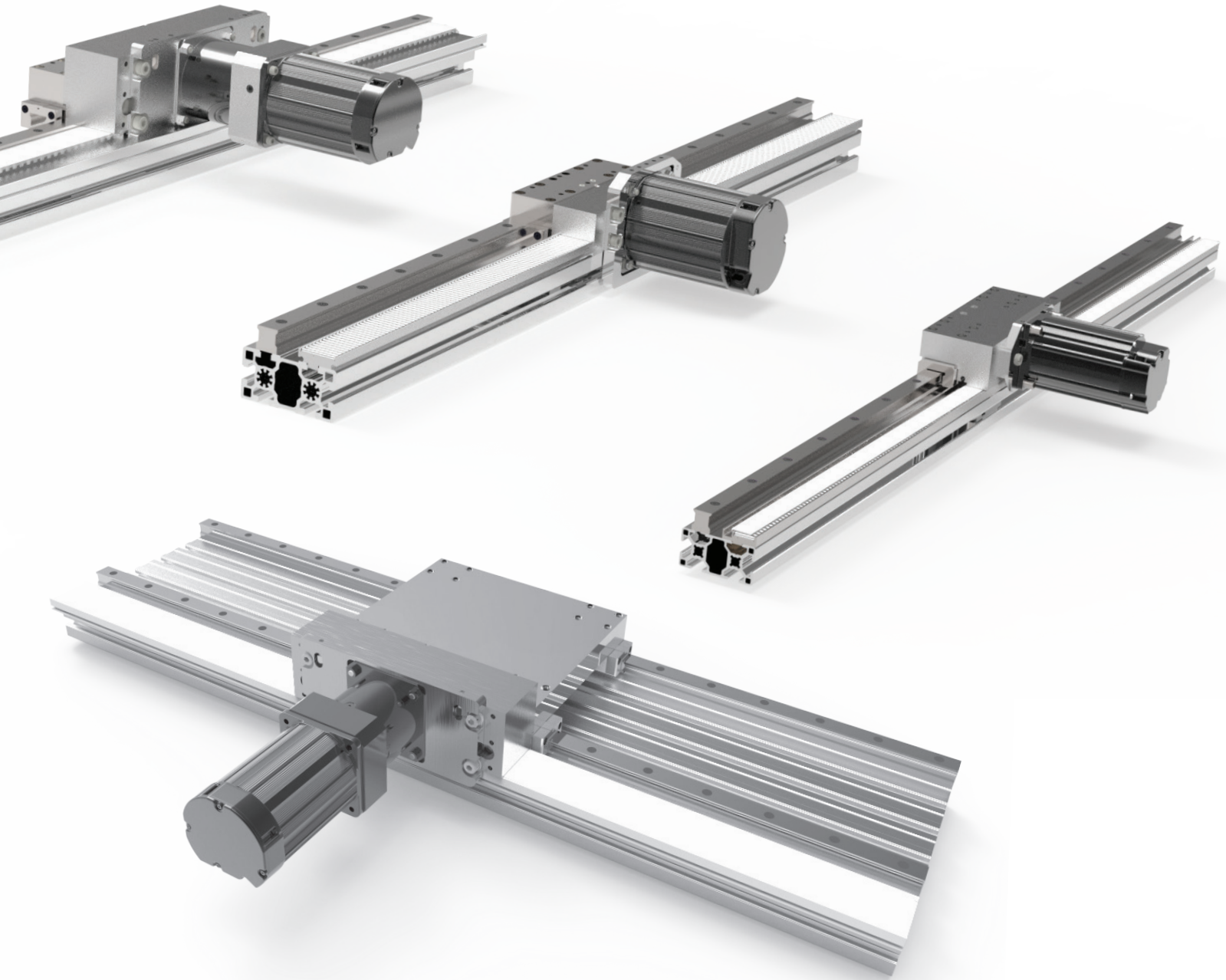



ServoBelt™ Linear

www.bell-everman.com

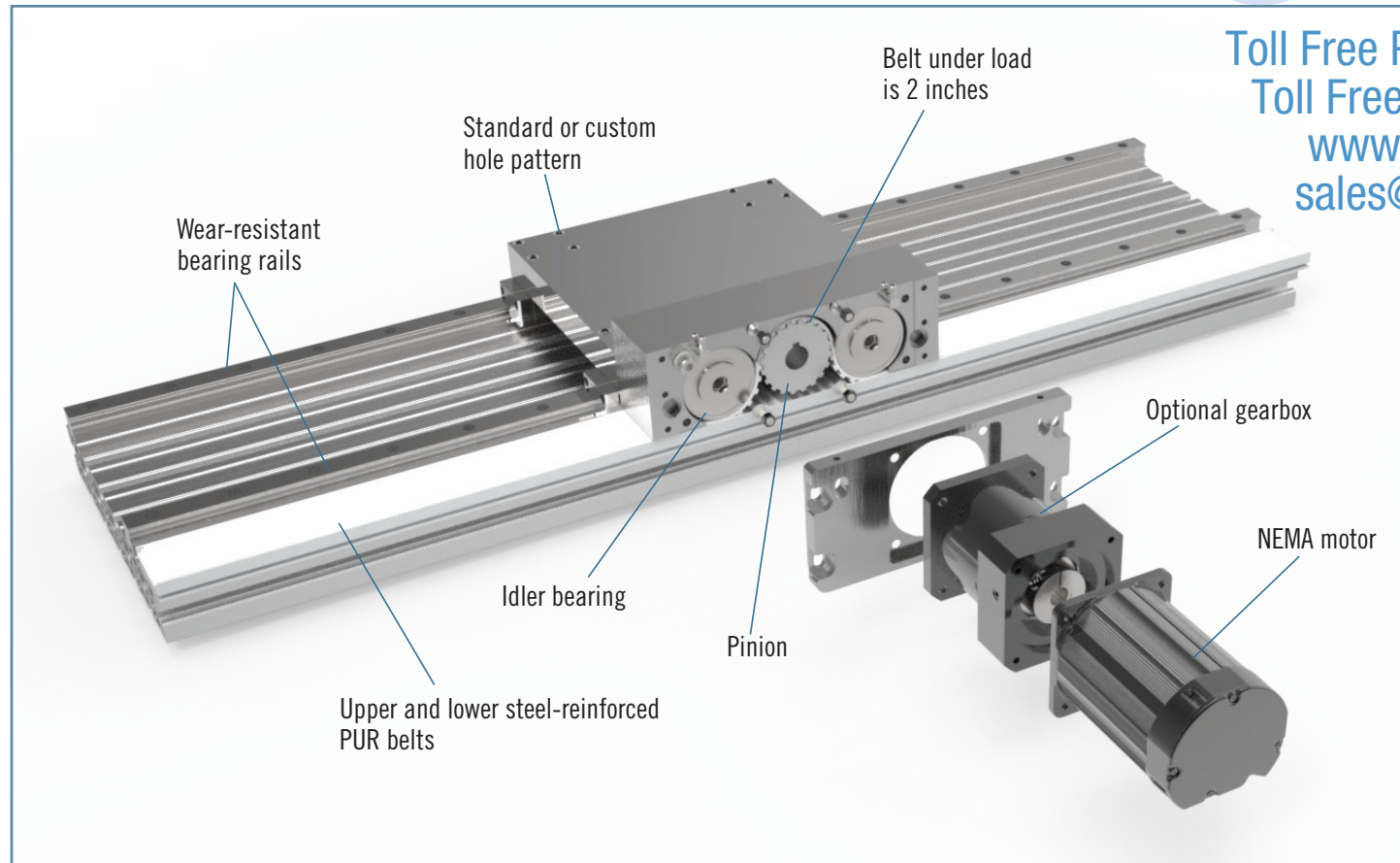
Toll Free Phone (877) SERV098
 Toll Free Fax (877) SERV099
www.electromate.com
sales@electromate.com

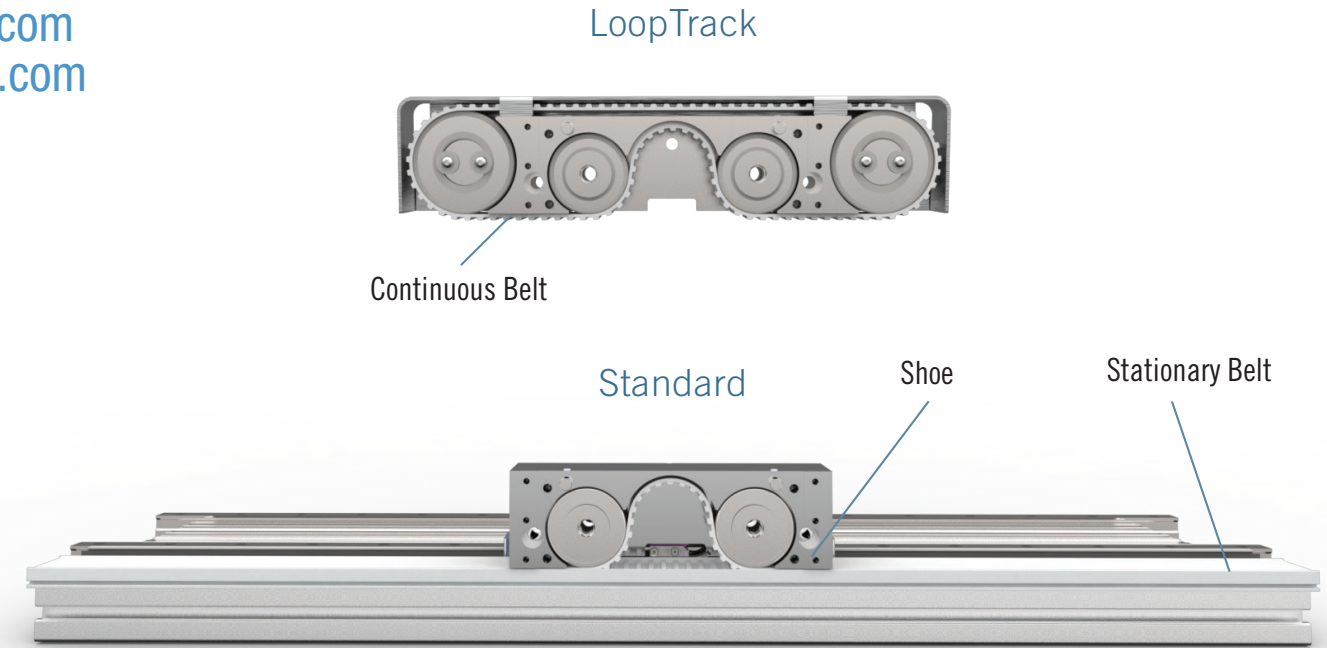

ServoBelt Carriage Styles



ServoBelt Linear comes in two different carriage styles. The **Standard** carriage is more compact and uses our dual-belt drive technology. This carriage style is suitable for most applications. The **LoopTrack** carriage is a design in which the upper drive belt loops continuously within the carriage itself. It prevents the possibility of belt sag in inverted or cantilevered applications. Both carriages have a new “shoe” feature that doubles the pullout strength of the belt teeth compared to early ServoBelt designs.

- **High Performance, Low Cost.** With speeds up to 4 m/s and repeatability up to $\pm 4 \mu\text{m}$ per meter, ServoBelt Linear compares favorably to high-end linear motor drives costing thousands more.
- **Limitless Scalability.** With a modular chassis based on standard Bosch-Rexroth T-slot extrusions, ServoBelt Linear offers virtually limitless travel distances, making it easy to create large-format motion systems.
- **Multiple Carriages and Axes.** A single ServoBelt Linear axis will support multiple carriages with independent motion. Multi-axis configurations include Cartesian motion systems and gantry robots.

Moments and Forces

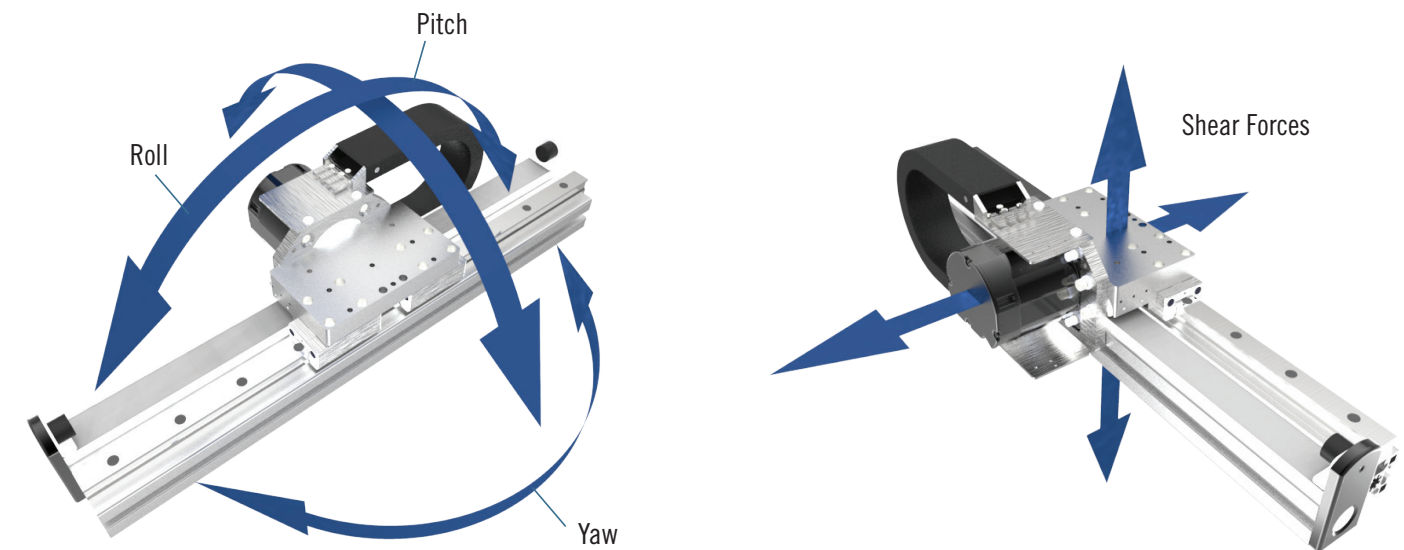

Custom Gantry



Lab Automation System

How Do I Size ServoBelt Linear?

Estimate Required Linear Force

- Convert your desired acceleration to g's.
- Determine moving weight in pounds by adding payload, carriage, motor and gearhead weights.
- Calculate linear force as weight × g's.

Select a ServoBelt Class

- Refer to **Maximum Force Table** and verify your application forces are under the recommended value.
- Refer to **Lifecycle Expectations Table** for the approximate life of the upper belt based on your application's force as percentage of Maximum Recommended.

Calculate Length

ServoBelt's overall length (OAL) will be the sum of your carriage length from the Carriage Table, hardstop dead length from the Hardstop Table and travel in 10-mm increments.

Think Rack-and-Pinion

ServoBelt Linear can also be analyzed in a number of motor sizing programs as a rack-and-pinion system. Use 23.87 as the pitch diameter for the Light and Medium models and 63.66 mm as the pitch diameter for the Heavy Model.

Carriage Table

	Carriage Weight (lb) less motor	Length (in)	Minimum Multi-Carriage Spacing (in)
SBL-L SHORT	2.39	4.33	n/a
SBL-L LONG	2.87	6.29	n/a
SBL-M-90	6.01	6.29	7.24
SBL-M-LT-90	6.76	6.29	8.66
SBL-M-180	10.07	6.29	7.24
SBL-M-LT-180	10.47	6.29	8.66
SBL-M-270	11.96	6.29	7.24
SBL-M-LT-270	13.48	6.29	8.66
SBL-H-90	11	9.84	10.75
SBL-H-LT-90	18.48	9.84	16.81
SBL-H-180	17	9.84	10.75
SBL-H-LT-180	23.27	9.84	16.81
SBL-H-270	21.4	9.84	10.75
SBL-H-LT-270	29	9.84	16.81

Notes:

1. -90 implies a single rail with two 4-hole 20 mm bearing blocks, -180 and -270 are dual rail.
2. ServoBelt Light not available with multi-carriage other than as a special.
3. ServoBelt Heavy always gets a gearhead because of its large pinion diameter. We have belt reducers available to allow a linear encoder loop closure.
4. Linear encoder requires use of long carriage.

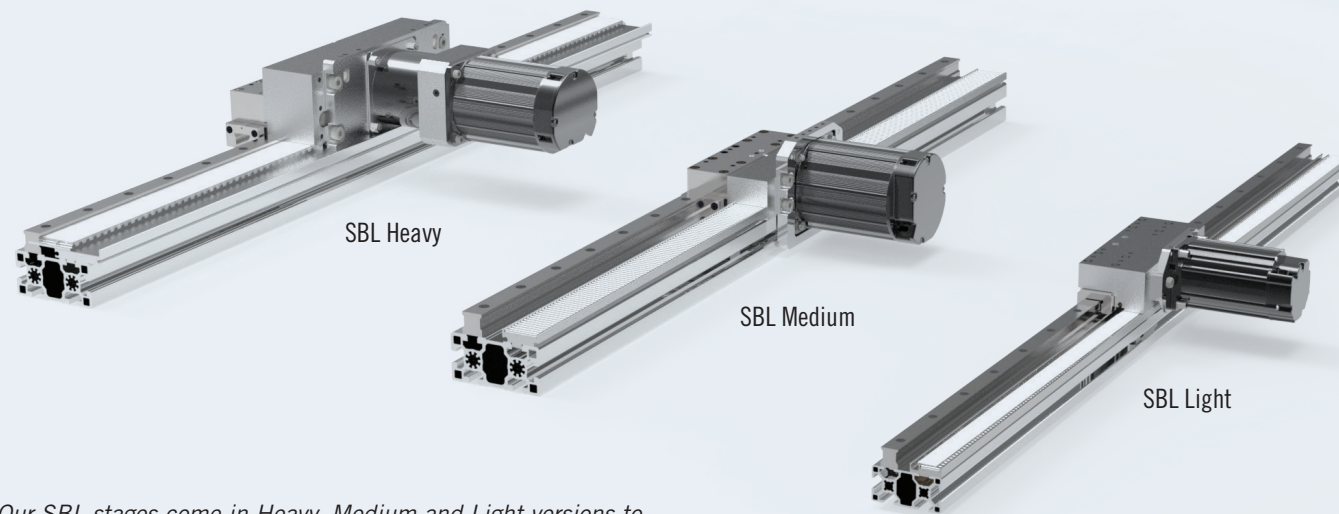

Our SBL stages come in Heavy, Medium and Light versions to meet a variety of force requirements.

Repeatability Range

Repeatability depends on the application's acceleration profile. Here's a range for all three models.

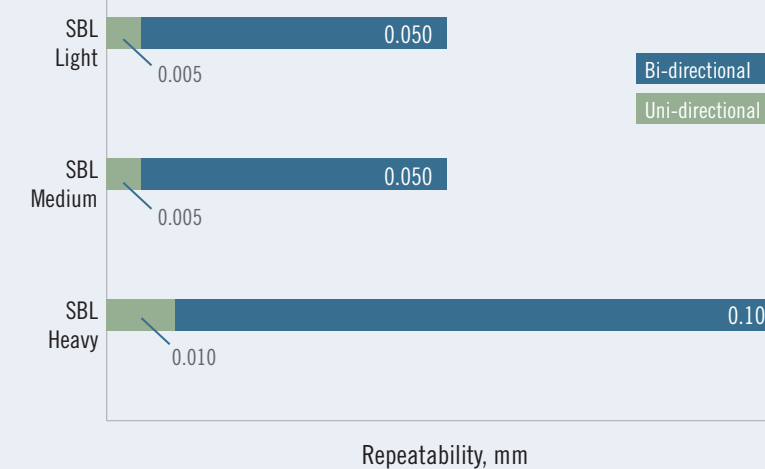

Bi-Directional repeatability can be greatly enhanced by experimentation with deceleration values. Ask us about this.

Hardstop Table

Type	Dead Length, standard (in)	Dead length, heavy style (in)
SBL-L	140 mm	190 mm
SBL-M	190 mm	240 mm
SBL-H	190 mm	240 mm

Notes:

1. Stops are hard rubber. Consult engineering for shock absorbers.

Lifecycle Expectations

As a function of recommended operating forces.

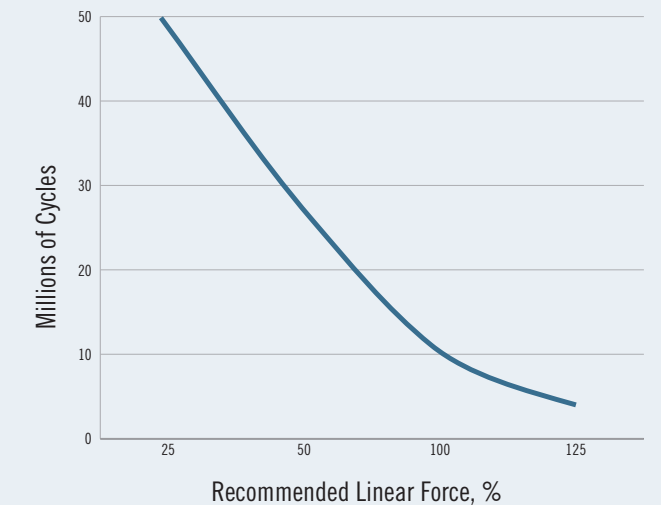

Notes:

1. Life curve extrapolated from test data.
2. At end of life, failure mode is detachment of a tooth from its reinforcement.
3. Replacement of the upper belt is all that would be required.
4. Life assumes a light, one time coat of mesh with food grade mineral oil.
5. Life numbers generated without retensioning or relubrication.

Maximum Linear Forces

SBL models differ primarily in the amount of linear force they can deliver.

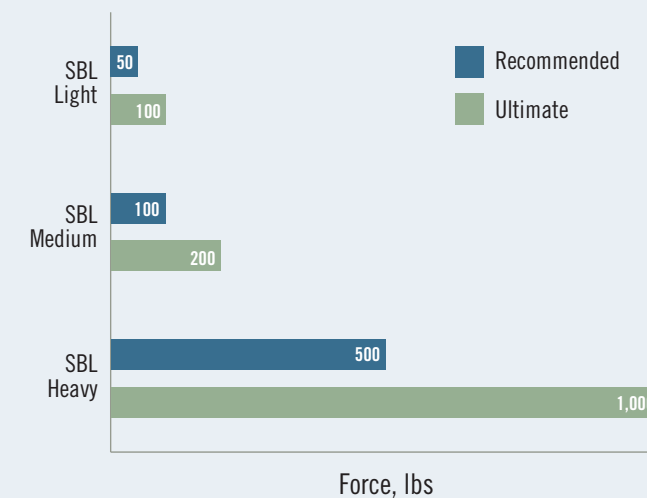

Ultimate Force Capacity is the load at which the belt will skip around the drive pinion. It is a non-destructive event but not intended as a repetitive overload protection.



Toll Free Phone (877) SERV098
 Toll Free Fax (877) SERV099
www.electromate.com
sales@electromate.com

Available Motors

The following chart lists specifications for the motors we supply. ServoBelt also supports equivalent motors chosen or supplied by our customers. ServoBelt quotes assume that we will modify an adapter plate if necessary, though your motor may already be in our large database of adapter plates. Customer furnished motors are installed after stage burn-in. If using our motors, refer to this table for a motor's maximum speed at a particular bus voltage. Note that Teknic Motors with integrated Clearpath drives do not exceed 75 vdc, or 4,500 RPM.

OVERVIEW	ServoBelt Linear		
	SBL-L ServoBelt Linear, Light Duty	SBL-M ServoBelt Linear, Medium Duty	SBL-H ServoBelt Linear, Heavy Duty
Type	Rotary Drive Linear, NEMA 23 or user motor	Rotary Drive Linear, NEMA 23, 34 or user motor	Rotary Drive Linear, NEMA 34 or user motor
Maximum Linear Force (lbs) Recommended Ultimate	50 100	100 200	500 1000
Linear travel Per pinion revolution (mm) Pitch Diameter	75 0.940		200 2.506
Bearing type	Preloaded 4-row recirculating ball, standard or corrosion resistant		
Maximum length	5.5 m with single-piece chassis Virtually limitless travel distances with chassis splices		
Motor type	3-phase brushless servo or user supplied of any type		
Accuracy (µm) Linear accuracy at stage centerline	Linear optical encoder: ±4 / meter Rotary encoder: ±135 / full travel		
Uni-directional repeatability (µm) Achievable under ideal conditions	±10		±15
Bi-directional repeatability (µm)	±25 to ±125 depending on deceleration profile		±80 to ±130 depending on deceleration profile
Angular deviation (±arc-sec) Yaw angle maximum in the plane of the base. Most chassis are flexible enough that this value is generally the achievable number when the unit is straightened on user surface.	±20		
Encoder type and resolutions: rotary (CPR), linear (µm)	16 KCPR (NEMA 23) rotary motor encoder; 1 µm magnetic linear; 1 µm, 0.5 µm, 0.2 µm, 0.1 µm optical linear	16 KCPR (NEMA 23), 16 KCPR (NEMA 34) rotary motor encoder; 1 µm magnetic linear; 1 µm, 0.5 µm, 0.2 µm, 0.1 µm optical linear	16 KCPR (NEMA 34) rotary motor encoder; 1 µm magnetic linear; 1 µm, 0.5 µm, 0.2 µm, 0.1 µm optical linear
Speed (m/sec)	4		
Max shear for 10 ⁶ m @ 2 m/sec (N)	840	2028 (single rail) 4057 (double rail)	
Max pitch and yaw moment for 10 ⁶ m @ 2 m/sec (N-m)	5.6	110 (single rail) 220 (double rail)	
Max roll moment for 10 ⁶ m @ 2m/sec (N-m)	5.6	25 (single rail) 183, 365, 232 (-180, -270, -90S)	25 (single rail) 183, 365 (-180, -270)
Ultimate dynamic belt life Out-and-back cycles to belt failure at load in Newtons	50 M cycles @ 13 lb 25 M cycles @ 25 lb 18 M cycles @ 38 lb 9 M cycles @ 50 lb	50 M cycles @ 25 lb 25 M cycles @ 50 lb 18 M cycles @ 75 lb 9 M cycles @ 100 lb	25 M cycles @ 300 lb

MOTOR	MOTOR TYPE	# OF POLES		Cont. Stall Torque or Force	KV	VMAX 24VDC	VMAX 48VDC	VMAX 75VDC	VMAX 150VDC	VMAX 300VDC	CONT OUTPUT	TMAX@VMAX		MOTOR WEIGHT	INERTIA			INDUCTANCE	RESISTANCE
		Number of poles	Oz-in									IN-LB	V/KRPM		Max RPM at stated DC bus voltage	Watts	OZ-IN		
---Our Rotary Motors---																			
Teknic 2311S	3-PH BLDC	8	60	3.75	12.38	700	2500	4500	6000	6000	228	51.0	3.2	1.38	0.0011	0.026543	0.0000077665	2.932	2.760
Teknic 2311P	3-PH BLDC	8	60	3.75	6.19	2900	6000	6000	6000	6000	228	51.0	3.2	1.38	0.0011	0.026543	0.0000077665	0.733	0.690
Teknic 2321S	3-PH BLDC	8	114	7.125	21	410	1500	2700	6000	6000	399	90.0	5.6	2.05	0.0023	0.055499	0.0000162390	3.662	2.464
Teknic 2321P	3-PH BLDC	8	114	7.125	10.5	1750	3900	6000	6000	6000	399	90.0	5.6	2.05	0.0023	0.055499	0.0000162390	0.915	0.616
Teknic 2331S	3-PH BLDC	8	153	9.5625	26.5	330	1150	2150	4900	6000	525	118.0	7.4	2.41	0.0035	0.084455	0.0000247115	3.545	2.418
Teknic 2331P	3-PH BLDC	8	153	9.5625	13.25	1500	3200	5200	6000	6000	525	118.0	7.4	2.41	0.0035	0.084455	0.0000247115	0.886	0.605
Teknic 2341S	3-PH BLDC	8	183	11.4375	35.36	230	900	1550	3750	6000	458	102.0	6.4	2.76	0.0049	0.118237	0.0000345961	4.585	2.980
Teknic 2341P	3-PH BLDC	8	183	11.4375	17.68	1050	2350	3800	6000	6000	458	102.0	6.4	2.76	0.0049	0.118237	0.0000345961	0.745	1.146
Teknic 3411S	3-PH BLDC	8	150	9.375	28.36	230	1000	2000	4600	6000	471	106.0	6.6	3.1	0.01	0.2413	0.0000706044	3.900	3.000
Teknic 3411P	3-PH BLDC	8	150	9.375	14.18	1000	2650	4500	6000	6000	471	106.0	6.6	3.1	0.01	0.2413	0.0000706044	0.975	0.750
Teknic 3421S	3-PH BLDC	8	288	18	46.76	230	700	1200	2750	6000	665	142.0	8.9	4.6	0.0206	0.497078	0.0001454450	4.791	2.496
Teknic 3421C	3-PH BLDC	8	288	18	23.38	700	1650	2750	6000	6000	665	142.0	8.9	4.6	0.0206	0.497078	0.0001454450	1.198	0.624
Teknic 3431S	3-PH BLDC	8	400	25	49.08	230	700	1200	2700	5000	656	119.0	7.4	6.2	0.0295	0.711835	0.0002082829	3.452	1.420
Teknic 3431C	3-PH BLDC	8	400	25	24.54	740	1650	2750	5000	5000	656	119.0	7.4	6.2	0.0295	0.711835	0.0002082829	0.863	0.355
Teknic 3441S	3-PH BLDC	8	478	29.875	78.78	80	350	720	1650	3600	657	223.0	13.9	7.88	0.0401	0.967613	0.0002831236	6.640	2.637
Teknic 3441P	3-PH BLDC	8	461	28.8125	39.39	350	930	1622	3550	4200	657	108.0	6.8	7.88	0.0401	0.967613	0.0002831236	1.660	0.659

Single Rail Configurations

Toll Free Phone (877) SERV099
 Toll Free Fax (877) SERV099
www.electromate.com
sales@electromate.com

Duty Class	Chassis X-Section (mm x mm) h x w	Description	Figure	Maximum Axial Force (lb)				Chassis Stiffness (million lb/in ²)		Chassis Weight (lb/in)
				Stall	0.5 m/s	2 m/s	4 m/s	vertical direction	horizontal direction	
SBL-Light Single Rail	30x60	short carriage (no linear encoder)	1A	35	27	21	18	4	6	0.20
	60x60		1B					19	11	0.26
	30x60	linear encoder- capable carriage	1A					4	6	0.20
	60x60		1B					19	11	0.26
SBL-Medium Single Rail	45x90	horizontal larger extrusion	2A	104	80	62	53	18	36	0.44
	45x180		2B					26	191	0.53
	45x270		2C					42	1009	1.14
	90x180		2D					135	339	0.86
	90x90		2E					85	57	0.51
	180x90		2F					462	104	0.86
SBL-Heavy Single Rail	45x90	vertical larger extrusion	2G	313	230	200	182	18	36	0.49
	45x180		2H					26	191	0.58
	45x270		2I					42	1009	1.19
	90x180		2J					135	339	0.90
	90x90		2K					85	57	0.56
	180x90		2L					462	104	0.90
SBL-Medium Single Rail	45x45	wrap-around	4A	104	80	62	53	4	12	0.32
	90x45		4B					36	11	0.44
	180x45		4C					242	17	0.53
	270x45		4D					1111	32	1.14
SBL-Heavy Single Rail	45x45	wrap-around	4E	313	230	200	182	4	12	0.37
	90x45		4F					36	11	0.49
	180x45		4G					242	17	0.58
	270x45		4H					1111	32	1.19

Dual Rail Configurations

Duty Class	Chassis X-Section (mm x mm) h x w	Description	Figure	Maximum Linear Force (lb) At Speed				Chassis Stiffness (million lb/in ²)		Chassis Weight (lb/in)
				Stall	0.5 m/s	2 m/s	4 m/s	vertical direction	horizontal direction	
SBL-Medium Dual Rail	45x180	horizontal larger extrusion	3A	104	80	62	53	33	259	0.69
	45x270		3B					53	1218	1.29
	90x180		3C					164	408	1.01
	90x90	3D	116					62	0.66	
	180x90	3E	589					109	1.01	
SBL-Heavy Dual Rail	45x180	horizontal larger extrusion	3F	313	230	200	182	33	259	0.74
	45x270		3G					53	1218	1.34
	90x180		3H					164	408	1.06
	90x90	3I	116					62	0.71	
	180x90	3J	589					109	1.06	
SBL-Medium Dual Rail	45x180	wrap-around	5A	104	80	62	53	328	20	0.69
	45x270		5B					1351	35	1.14
SBL-Heavy Dual Rail	45x180		5C	313	230	200	182	328	20	0.74
	45x270		5D					1351	35	1.34

Multiple Carriage LoopTrack

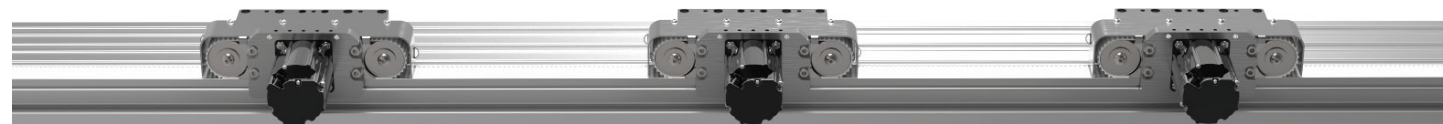

ServoBelt LoopTrack supports multiple, independently moving carriages.

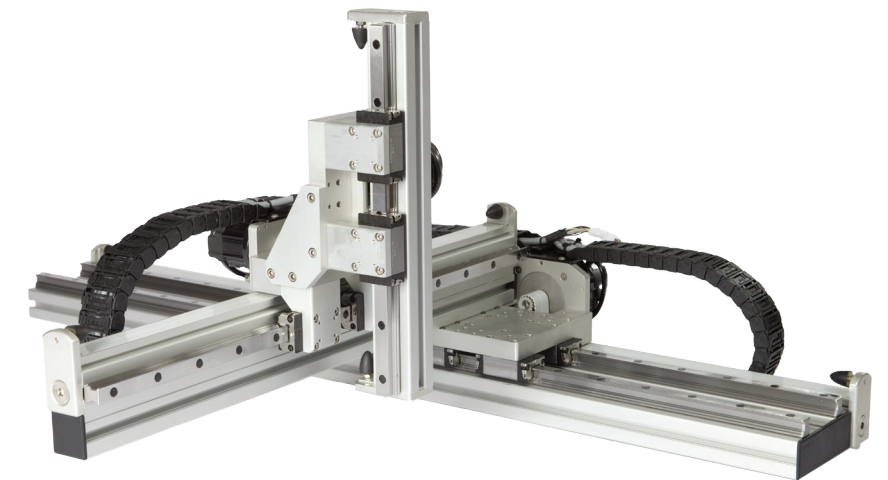
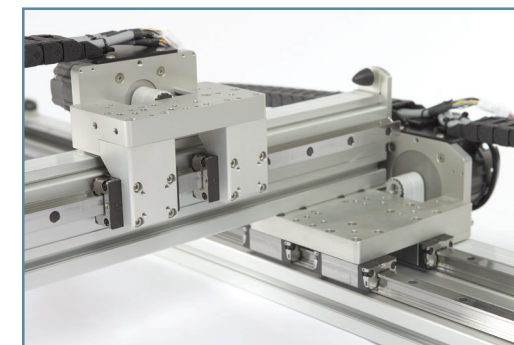

Sold & Serviced By:

 **ELECTROMATE**

Toll Free Phone (877) SERV098

Toll Free Fax (877) SERV099

www.electromate.com

sales@electromate.com

Bell-Everman

82 Aero Camino, Goleta, CA (805) 685-1029

