

## DS-W

- Single output shaft configuration with our high performance bellow coupling input and machined motor flange to mount to any servo motor
- Frame sizes from 55 mm to 190 mm
- ⚠ DSX option available

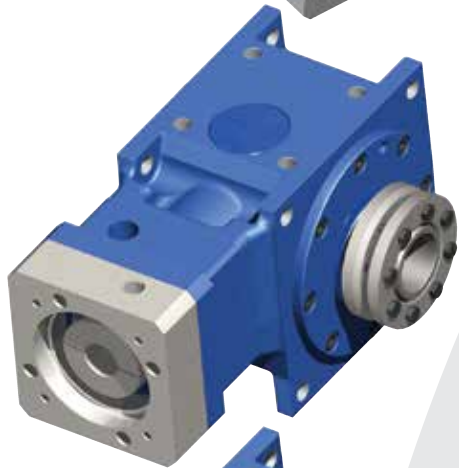

## DS-H

- Hollow bore output configuration with our high performance bellow coupling input and machined motor flange to mount to any servo motor
- Zero-backlash shrink disk coupling on the output included with the gearbox
- Frame sizes from 55 mm to 190 mm
- ⚠ DSX option available

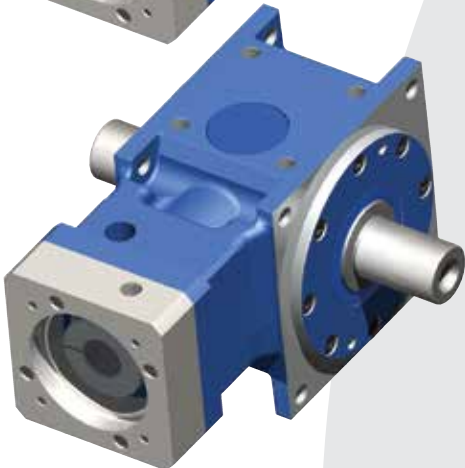

## DS-T

- Dual output shaft configuration with our high performance bellow coupling input and machined motor flange to mount to any servo motor
- Frame sizes from 55 mm to 190 mm
- ⚠ DSX option available



## DS-F

- Flange output allows connection of pinion gears, pulleys, rotary index tables, and transmission shafting directly to the output for a more compact and stiffer solution
- Frame sizes from 55 mm to 190 mm
- ⚠ DSX option available

Sold & Serviced By:

 **ELECTROMATE**

Toll Free Phone (877) SERV098

Toll Free Fax (877) SERV099

[www.electromate.com](http://www.electromate.com)

[sales@electromate.com](mailto:sales@electromate.com)



# ▶ HIGHEST PERFORMANCE: DYNA SERIES

## The Advantage of Hypoid Gearing

The GAM Hypoid offers significant advantages over other conventional right-angle gears.

Conventional spiral bevel gearing, meshing in the position shown at the bottom of the drawing, has a purely rolling meshing action that is mechanically very efficient. Its drawback is that it offers the smallest total tooth contact area, so its torque throughput capacity is lower. Single-stage spiral bevel gearing is limited to about a 6:1 reduction ratio. It's easy to get higher ratios with multiple-stage configurations, but the additional gear stage lowers mechanical efficiency, increases backlash, consumes space and weight and reduces reliability.

Conventional worm gearing, meshing in the position shown at the top of the drawing, has a very high total tooth contact area. While it offers high torque throughput and high ratio reduction, worm gearing has the lowest mechanical efficiency, due to the friction generated by its high component of sliding action. Worm gearing is also subject to the kind of wear that demands adjustment in order to maintain accuracy.

Hypoid gearing, meshing at the intermediate position, offers mostly rolling action with a small component of sliding action. It has a greater tooth contact area than bevel gearing, so its load-carrying capability is greater. The GAM Hypoid offers further advantages by going up to a 15:1 gear ratio in a single stage with efficiencies between 93% and 96%, depending upon ratio throughout the speed range. Another important design criterion for precision servo applications is, of course, low backlash in the gear box.

### The GAM Hypoid offers two important advantages:

- Single-stage design eliminates backlash from a second set of meshing gears
- Accurate machining and assembly alignment – high-accuracy models offer backlash of  $\leq 2$  arcminutes.

GAM Hypoid gearing is available in two product ranges, our highest precision Dyna Series, and high precision, Dyna-Lite Series.

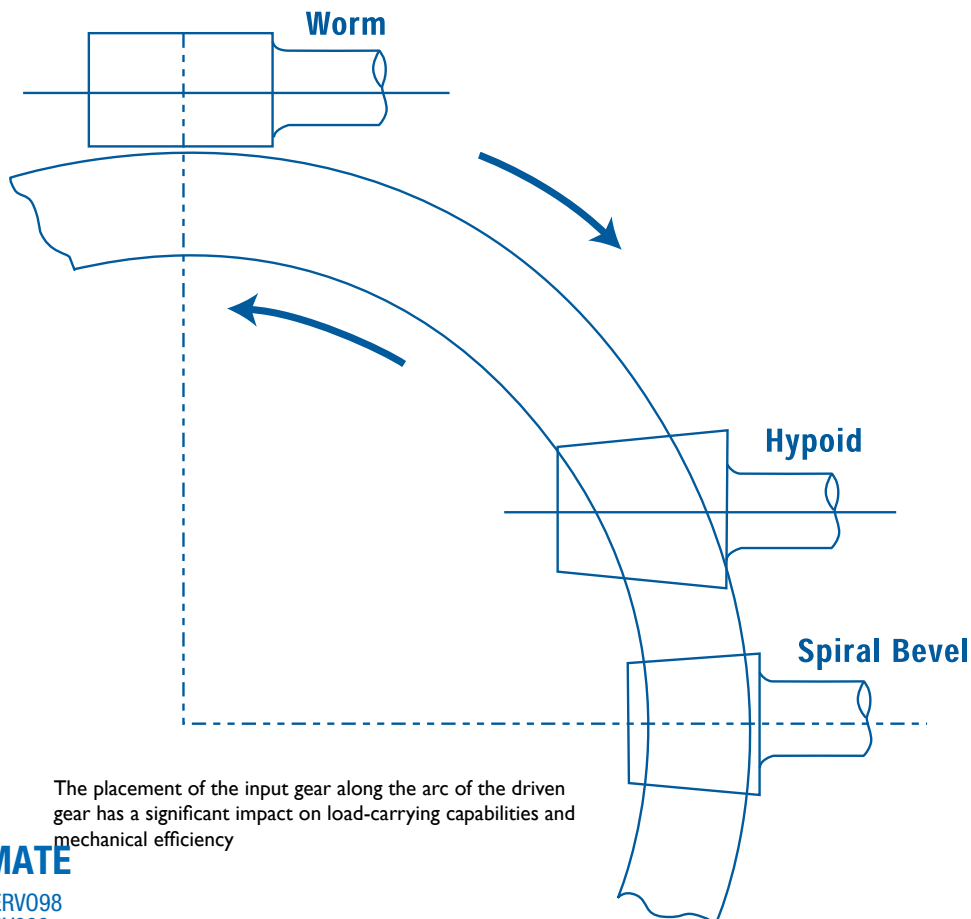

The placement of the input gear along the arc of the driven gear has a significant impact on load-carrying capabilities and mechanical efficiency

Sold & Serviced By:

ELECTROMATE

Toll Free Phone (877) SERV098

Toll Free Fax (877) SERV099

51 www.electromate.com

sales@electromate.com

# HIGHEST PERFORMANCE: DYNA SERIES

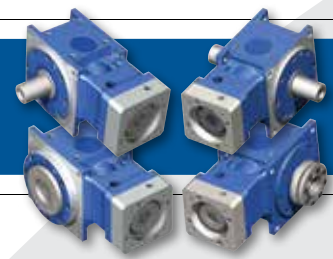

Dyna Series		55	75	90	115	140	190	
Stock Ratios <sup>1)</sup>		3, 5, 10, 15, 30, 50, 100			3, 5, 10, 15		N/A	
All Ratios Available		1-stage: 3, 4, 5, 6, 8, 10, 12, 15			2-stage: 25, 30, 40, 50, 70, 100		3-stage: consult GAM	
Nominal Output Torque ( $T_{2n}$ )	Nm (lb-in)	3:1	35 (310)	70 (620)	140 (1239)	260 (2301)	700 (6196)	1400 (12391)
		4:1	34 (301)	68 (602)	136 (1204)	255 (2257)	690 (6107)	1350 (11949)
		5:1	33 (292)	65 (575)	131 (1159)	250 (2213)	670 (5930)	1280 (11329)
		6:1	32 (283)	61 (540)	124 (1097)	240 (2124)	660 (5841)	1200 (10621)
		8:1	30 (266)	56 (496)	115 (1018)	220 (1947)	640 (5664)	1120 (9913)
		10:1	28 (248)	53 (469)	105 (929)	200 (1770)	560 (4956)	1040 (9205)
		12:1	25 (221)	50 (443)	95 (841)	180 (1593)	480 (4248)	950 (8408)
		15:1	22 (195)	45 (398)	80 (708)	160 (1416)	400 (3540)	800 (7081)
	All 2-Stage Ratios	35 (310)	70 (620)	140 (1239)	260 (2301)	700 (6196)	1400 (12391)	
Max Acceleration Output Torque ( $T_{2a}$ )	Nm (lb-in)	-	1.5 x Nominal	1.5 x Nominal	1.5 x Nominal	1.5 x Nominal	1.5 x Nominal	
Emergency Output Torque ( $T_{2not}$ )	Nm (lb-in)	3:1-6:1	70 (620)	140 (1239)	280 (2478)	520 (4602)	1400 (12391)	2800 (24782)
		8:1-10:1	60 (531)	110 (974)	230 (2036)	440 (3894)	1280 (11329)	2240 (19826)
		12:1-15:1	50 (443)	100 (885)	190 (1682)	360 (3186)	960 (8497)	1900 (16816)
		All 2-Stage Ratios	70 (620)	140 (1239)	280 (2478)	520 (4602)	1400 (12391)	2800 (24782)
Nominal Input Speed <sup>6)</sup> ( $n_{1n}$ )	RPM	1 Stage	6000	6000	5000	4000	3000	2500
		2 Stage	3000	3000	3200	3200	2800	2500
Max Input Speed <sup>6)</sup> ( $n_{1max}$ )	RPM	1 Stage	8000	8000	7000	6000	5000	4500
		2 Stage	6000	6000	6000	6000	6000	4500
Standard Output Backlash (j)	arcmin	1 Stage	<5	<5	<4	<4	<4	<4
		2 Stage	<7	<7	<6	<6	<6	<6
Reduced Output Backlash (j)	arcmin	1 Stage	<3	<3	<2	<2	<2	<2
		2 Stage	<4	<4	<3	<3	<3	<3
Noise Level ( $L_{pA}$ )	dB	-	<70	<71	<74	<74	<74	
Allowable Radial Load <sup>4)</sup> ( $F_{rad}$ )	N (lbs)	-	3500 (787)	3800 (854)	4000 (899)	7500 (1686)	11000 (2473)	15000 (3372)
Allowable Axial Load ( $F_{axial}$ )	N (lbs)	-	1400 (315)	1520 (342)	1600 (360)	3000 (674)	4400 (989)	6000 (1349)
Maximum Tilting Moment	Nm (lb-in)	-	145 (1283)	173 (1531)	238 (2106)	510 (4513)	990 (8763)	1650 (14604)
Torsional Stiffness ( $C_{21}$ ) <sup>5)</sup>	Nm/arcmin (lb-in/arcmin)	1 Stage	2.1 (18.6)	4.2 (37.2)	10.5 (92.9)	23.4 (207.1)	61.8 (547.0)	126 (1115.2)
		2 Stage	2.1 (18.6)	4.2 (37.2)	10.2 (90.3)	22.8 (201.8)	60.1 (531.9)	119.2 (1055.0)
Weight (m)	kg (lbs)	1 Stage	3 (6.6)	6 (13.2)	10 (22.0)	17 (37.5)	39 (86.0)	55 (121.3)
		2 Stage	4 (8.8)	7 (15.4)	11 (24.3)	22 (48.5)	49 (108.0)	65 (143.3)
Mass Moment of Inertia	kg cm <sup>2</sup> (lb-in <sup>2</sup> )	3:1	0.584 (0.200)	1.32 (0.451)	3.41 (1.165)	8.49 (2.901)	29.7 (10.149)	91.3 (31.199)
		4:1	0.439 (0.150)	0.993 (0.339)	2.46 (0.841)	6.03 (2.061)	20 (6.834)	61.2 (20.913)
		5:1	0.357 (0.122)	0.834 (0.285)	1.98 (0.677)	4.79 (1.637)	14.7 (5.023)	45.1 (15.412)
		6:1	0.258 (0.088)	0.747 (0.255)	1.24 (0.424)	4.04 (1.381)	11.7 (3.998)	34.9 (11.926)
		8:1	0.214 (0.073)	0.654 (0.223)	0.958 (0.327)	3.36 (1.148)	9.08 (3.103)	25.8 (8.816)
		10:1	0.192 (0.066)	0.612 (0.209)	0.842 (0.288)	3.04 (1.039)	7.85 (2.683)	21.8 (7.449)
		12:1	0.181 (0.062)	0.592 (0.202)	0.78 (0.267)	2.87 (0.981)	7.14 (2.440)	19.6 (6.698)
		15:1	0.17 (0.058)	0.568 (0.194)	0.715 (0.244)	2.72 (0.929)	6.55 (2.238)	19.5 (6.664)
		30:1	0.405 (0.138)	0.487 (0.166)	1.309 (0.447)	4.043 (1.382)	7.100 (2.426)	13.944 (4.765)
		40:1	0.367 (0.126)	0.402 (0.137)	1.084 (0.370)	3.477 (1.188)	5.050 (1.726)	7.625 (2.606)
		50:1	0.354 (0.121)	0.373 (0.128)	1.009 (0.345)	3.292 (1.125)	4.388 (1.499)	5.604 (1.915)
70:1	0.352 (0.120)	0.356 (0.122)	0.978 (0.334)	3.430 (1.172)	4.779 (1.633)	4.918 (1.681)		
100:1	0.342 (0.117)	0.346 (0.118)	0.938 (0.321)	3.130 (1.070)	3.879 (1.325)	4.018 (1.373)		
Efficiency at Load		3:1 - 8:1 > 96%		10:1 - 15:1 > 93%	30:1 - 100:1 > 92%			
Service Life		>30,000 hours						
Lubrication		Synthetic Oil: ISO VG 100						
Protection Rating		IP 64						
Operating Temperature Range		-10°C to 90°C						

Sold & Serviced By: ELECTROMATE



1) Stock ratios listed are available in Standard AND Reduced Backlash. 2) Nominal torque and speed values listed are for gear tooth ratings. Use thermal limit for continuous operation. 3) DSX Precision ground gearing for quieter and smoother operation, improved accuracy, and repeatability. 4) Load applied at center of output shaft @400 RPM. 5) Stiffness values relate to DS-W version only. Stiffness for DS-H,F may vary slightly- contact GAM for values. 6) Higher input speeds may be possible - consult GAM.

Toll Free Phone: 1-877-SERV098  
Toll Free Fax: 1-877-SERV099  
www.electromate.com  
sales@electromate.com



# ▶ DYNA SERIES - DS-W, DS-H, DS-T, DS-F

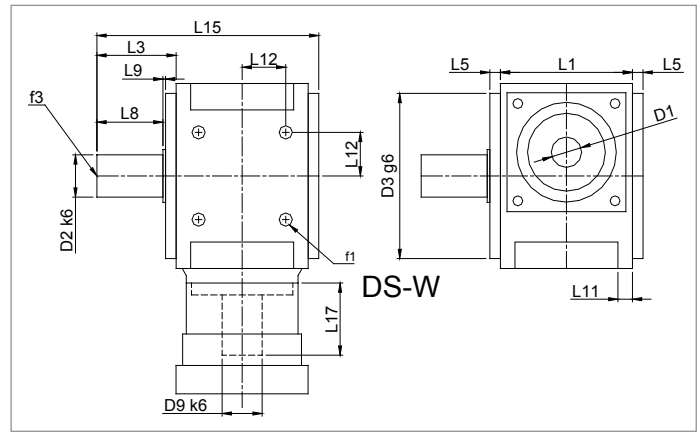
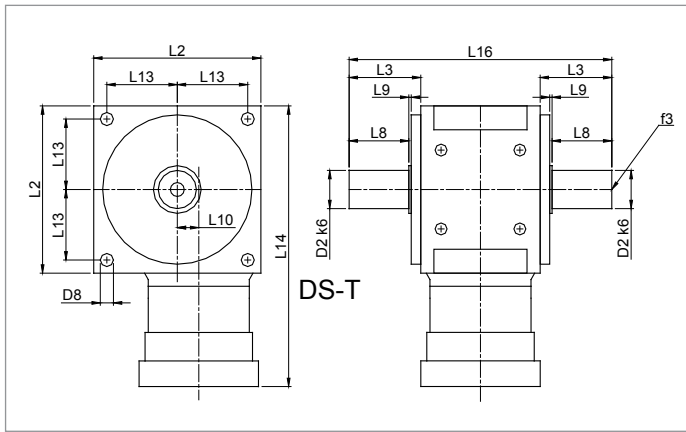
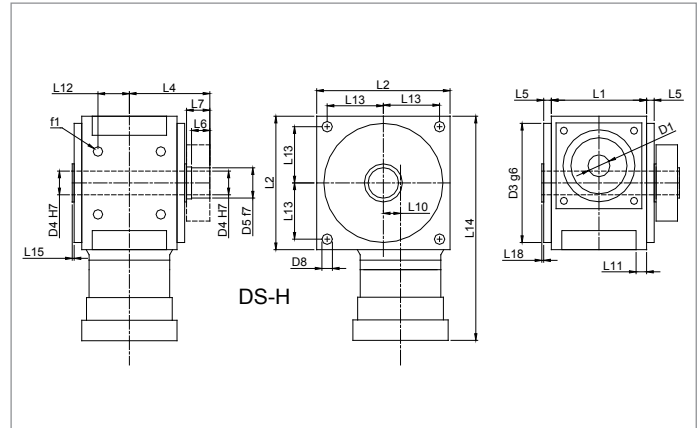
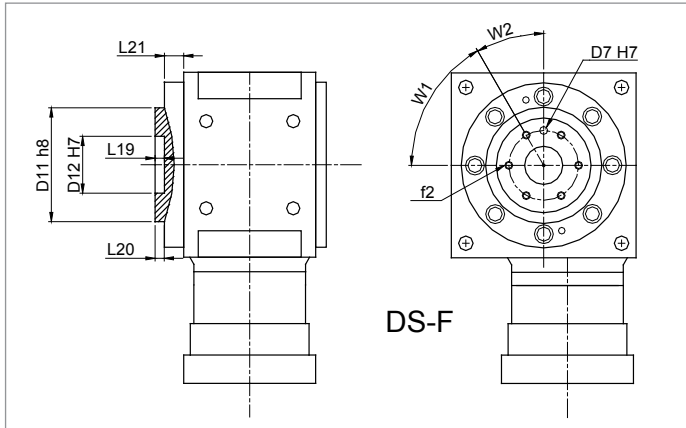

### Recommended Output Coupling (if necessary)

metal bellows	KM-60	KM-170	KM-270	KM-400	KM-1300	KSD-2500
elastomer	EKM-60	EKM-150	EKM-300	EKM-500	EKM-1000	-

### TYPE CODES FOR DYNA SERIES

**Example: DS - W B - 090 - 005 G - [115-201] - S111**

**Gearbox Series**  
DS = Dyna Series  
DSX = Dyna Series Extreme

**Gearbox Style**  
W = Single output shaft  
T = Dual output shaft  
H = Hollow output shaft  
F = Flange output

**Input Type**  
B = Bellows coupling input  
E = Elastomer coupling input  
L = Shaft input

**Gearbox Size**  
055, 075, 090, 115, 130, 140, 160, 190

**Ratio**  
003, 004, 005, 006, 008, 010,  
012, 015, 019, 040, 050, 070, 100

**Special Options**  
Assigned by GAM

**Motor Mount Kit**  
Assigned by GAM

#### Options Available for This Product

	LOW	OUTPUT
OPTION	BACKLASH	KEYWAY
A=	Y	N
C=	Y	Y
G=	N	Y
H=	N	N

Options C and G N/A for DS-F/H models.

#### Tolerances (mm)

Size	k6	g6	h8	f7	H7	h6
Over 6	+0.010	-0.005	0	-0.013	+0.015	0
Thru 10	+0.001	-0.014	-0.022	-0.028	0	-0.009
Over 10	+0.012	-0.006	0	-0.016	+0.018	0
Thru 18	+0.001	-0.017	-0.027	-0.034	0	-0.011
Over 18	+0.015	-0.007	0	-0.02	+0.021	0
Thru 30	+0.002	-0.020	-0.033	-0.041	0	-0.013
Over 30	+0.018	-0.009	0	-0.025	+0.025	0
Thru 50	+0.002	-0.025	-0.039	-0.05	0	-0.016
Over 50	+0.021	-0.010	0	-0.03	+0.030	0
Thru 80	+0.002	-0.029	-0.046	-0.06	0	-0.019
Over 80	+0.025	-0.012	0	-0.036	+0.035	0
Thru 120	+0.003	-0.034	-0.054	-0.021	0	-0.022
Over 120	+0.028	-0.014	0	-0.043	+0.040	0
Thru 180	+0.003	-0.039	-0.063	-0.083	0	-0.025

Dyna Series		55		75		90		115		140		190	
		mm	(in)	mm	(in)	mm	(in)	mm	(in)	mm	(in)	mm	(in)
D1 <sub>max 1-stage*</sub>	input shaft diameter	21	(0.827)	28	(1.102)	35	(1.378)	43	(1.693)	55	(2.165)	55	(2.165)
D1 <sub>max 2-stage*</sub>		14	(0.551)	14	(0.551)	24	(0.945)	24	(0.945)	38	(1.496)	38	(1.496)
D3 g6	pilot diameter	89	(3.504)	105	(4.134)	125	(4.921)	150	(5.906)	195	(7.677)	245	(9.646)
D8	mounting hole diameter	6.6	(0.26)	9	(0.354)	11	(0.433)	14	(0.551)	17.5	(0.689)	17.5	(0.689)
D9 k6	gearbox input shaft dia	14	(0.551)	18	(0.709)	22	(0.866)	28	(1.102)	32	(1.26)	40	(1.575)
f1	mounting hole thread	M6		M8		M10		M12		M16		M16	
L1	housing width	60	(2.362)	80	(3.15)	100	(3.937)	120	(4.724)	146	(5.748)	196	(7.717)
L2	housing size	90	(3.543)	115	(4.528)	140	(5.512)	170	(6.693)	215	(8.465)	260	(10.236)
L5	pilot height	13.5	(0.531)	8.5	(0.335)	8	(0.315)	8	(0.315)	10	(0.394)	10	(0.394)
L10	hypoid offset	9	(0.354)	14	(0.551)	18	(0.709)	23	(0.906)	32	(1.26)	42	(1.654)
L11	flange thickness	8	(0.315)	10	(0.394)	11	(0.433)	13	(0.512)	15	(0.591)	17	(0.669)
L12	hole location	22	(0.866)	27	(1.063)	33	(1.299)	40	(1.575)	52	(2.047)	70	(2.756)
L13	hole location	39	(1.535)	49	(1.929)	59	(2.323)	72	(2.835)	91	(3.583)	112	(4.409)
L14 1-stage**	input length	181	(7.126)	219	(8.622)	250.5	(9.862)	286.5	(11.28)	363.5	(14.311)	439	(17.283)
L14 2-stage**		229.5	(9.035)	262	(10.315)	247.5	(9.744)	280	(11.024)	372	(14.646)	591	(23.268)
L17	input shaft length	20	(0.787)	26	(1.024)	43	(1.693)	48	(1.89)	55	(2.165)	62	(2.441)

\* for larger shaft diameters consult GAM \*\* depending on motor, length may vary

DS-F & DS-H		55		75		90		115		140		190	
		mm	(in)	mm	(in)	mm	(in)	mm	(in)	mm	(in)	mm	(in)
D4 H7**	hollow bore	20	(0.787)	25	(0.984)	30	(1.181)	40	(1.575)	55	(2.165)	70	(2.756)
D5 f7	hollow outer diameter	24	(0.945)	30	(1.181)	36	(1.417)	50	(1.969)	68	(2.677)	80	(3.15)
D6	flange bolt circle	40	(1.575)	50	(1.969)	63	(2.48)	80	(3.15)	100	(3.937)	125	(4.921)
D7 H7	locating hole diameter	6	(0.236)	6	(0.236)	6	(0.236)	8	(0.315)	8	(0.315)	10	(0.394)
D11 h8	flange pilot (OD)	50	(1.969)	63	(2.48)	80	(3.15)	100	(3.937)	125	(4.921)	160	(6.299)
D12 H7	flange pilot (ID)	25	(0.984)	31.5	(1.24)	40	(1.575)	50	(1.969)	63	(2.48)	80	(3.15)
f2	flange tapped holes	7 x M6x9		7 x M6x9		7 x M6x9		11 x M8x12		11 x M8x12		11 x M10x15	
L4	hollow hub length	73	(2.874)	81	(3.189)	95	(3.74)	109	(4.291)	129	(5.079)	161	(6.339)
L6	hub length	20	(0.787)	22	(0.866)	26	(1.024)	29	(1.142)	32	(1.26)	34	(1.339)
L7	shoulder + hub length	23	(0.906)	25	(0.984)	29	(1.142)	33	(1.299)	37	(1.457)	40	(1.575)
L18	shoulder height	1.5	(0.059)	1.5	(0.059)	2	(0.079)	2	(0.079)	2	(0.079)	2	(0.079)
L19	inner flange pilot depth	6.5	(0.256)	6.5	(0.256)	6.5	(0.256)	8.5	(0.335)	8.5	(0.335)	10.5	(0.413)
L20	outer flange pilot height	6.5	(0.256)	6.5	(0.256)	6.5	(0.256)	8.5	(0.335)	8.5	(0.335)	8.5	(0.335)
L21	pilot height	20	(0.787)	15.5	(0.61)	17	(0.669)	20	(0.787)	17.5	(0.689)	22.5	(0.886)
W1	hole angle 1	45°		45°		45°		30°		30°		30°	
W2	hole angle 2	45°		45°		45°		30°		30°		30°	

\* for larger shaft diameters, consult GAM \*\* mating shaft should have h6 tolerance \*\*\* depending on motor, length may vary

DS-W & DS-T		55		75		90		115		140		190	
		mm	(in)	mm	(in)	mm	(in)	mm	(in)	mm	(in)	mm	(in)
D2 k6	output shaft diameter	20	(0.787)	24	(0.945)	32	(1.26)	40	(1.575)	55	(2.165)	70	(2.756)
f3	shaft thread per DIN332/1	M6x16		M8x19		M12x28		M16x36		M20x42		M20x42	
L3	output shaft length	50	(1.969)	50	(1.969)	60	(2.362)	70	(2.756)	102	(4.016)	122	(4.803)
L8	usable shaft length	35	(1.378)	40	(1.575)	50	(1.969)	60	(2.362)	90	(3.543)	110	(4.331)
L9	shoulder height	1.5	(0.059)	1.5	(0.059)	2	(0.079)	2	(0.079)	2	(0.079)	2	(0.079)
L15	gearbox width	123.5	(4.862)	138.5	(5.453)	168	(6.614)	198	(7.795)	258	(10.157)	328	(12.913)
L16	gearbox width	160	(6.299)	180	(7.087)	220	(8.661)	260	(10.236)	350	(13.78)	440	(17.323)

\*\* depending on motor, length may vary



## ▶ HIGH PERFORMANCE: DYNA-LITE SERIES

### GAM can.

If you don't see exactly what you need, let us know. We can modify the Dyna-Lite Series gearboxes to meet your needs. Page 4 provides a list of commonly requested modifications to give you a feel for our capabilities.

Now there's a right-angle gearbox that has the performance and price point of a precision in-line gearbox. Our redesigned Dyna-Lite Series use hypoid gearing that combines the space and configuration advantages of worm gearing with the high efficiency of bevel gearing. It is drop-in replacement for many right-angle and in-line planetary gear reducers.

### Dyna-Lite Series benefits include:

- High efficiency – 96%
- Standard backlash < 6 arcmin
- Back drivable
- High radial loading
- Available in shaft output and hollow output

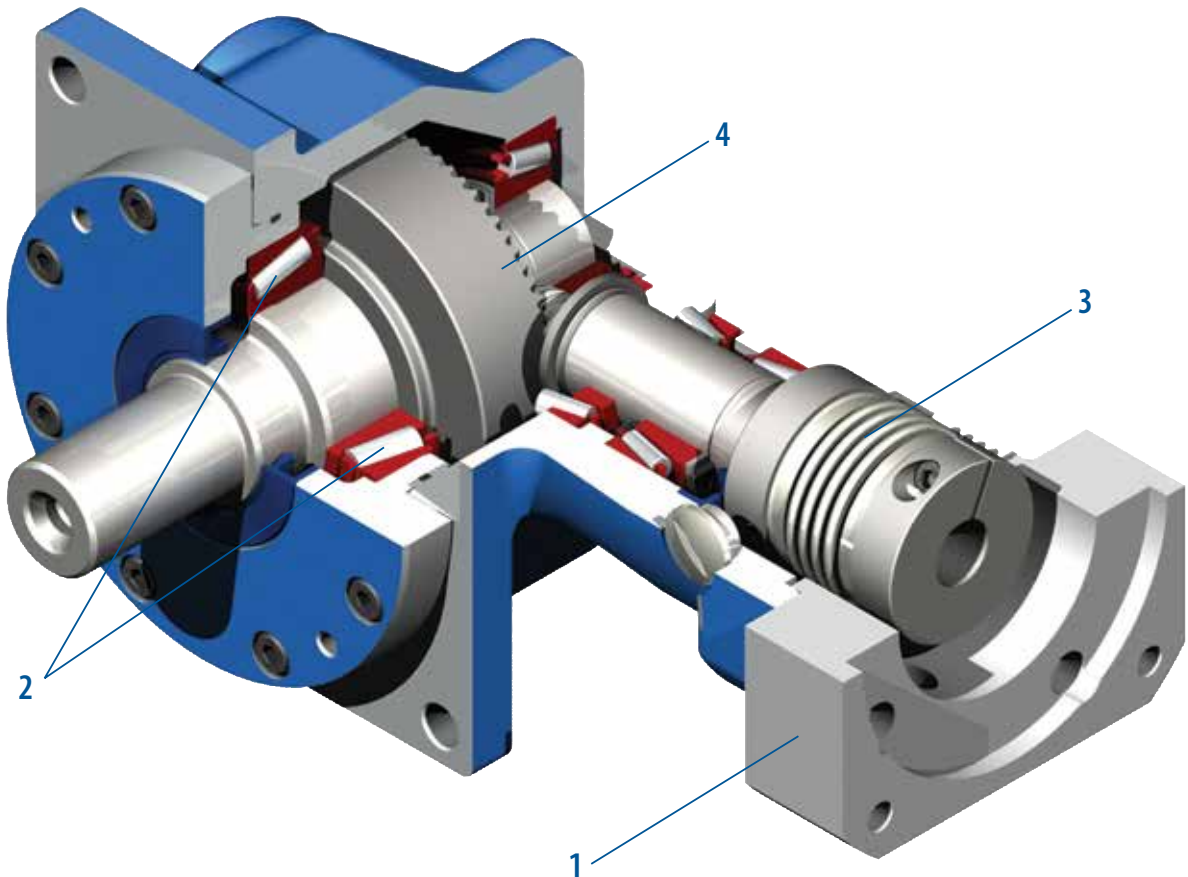

1. Adapter Plate  
(Allows for quick and easy motor mounting)

2. Bearings  
(Taper roller bearings allows high radial loading of output shaft)

3. Bellows Coupling  
(Bellows coupling for quick motor mounting)

4. Hypoid Gearing  
(Optimized gearing allows ratios up to 15:1 in a single stage; 150:1 in two stages)

Sold & Serviced By:

 ELECTROMATE

Toll Free Phone (877) SERV098  
Toll Free Fax (877) SERV099

55 www.electromate.com  
sales@electromate.com

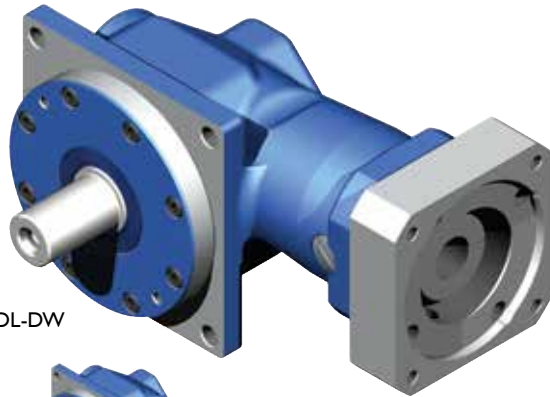

DL-DW



DL-DW High Ratio  
(High Ratio available on all versions)

## DL-DW

- Single output shaft configuration with our high performance bellow coupling
- Input and housing to mount to any servo motor
- Ratios up to 15:1 in a single stage and 150:1 in two stages
- Frame sizes: 55, 75 and 90 mm
- Drop-in for our highest precision Dyna Series

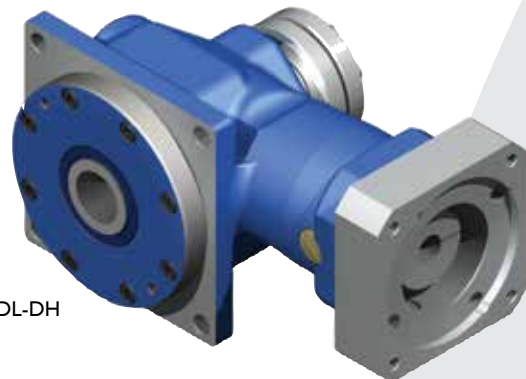

DL-DH

## DL-DH

- Smooth hollow output shaft configuration (includes shrink disc)
- Input and housing to mount to any servo motor
- Ratios up to 15:1 in a single stage and 150:1 in two stages
- Frame sizes: 55, 75 and 90 mm
- Drop-in for our highest precision Dyna Series

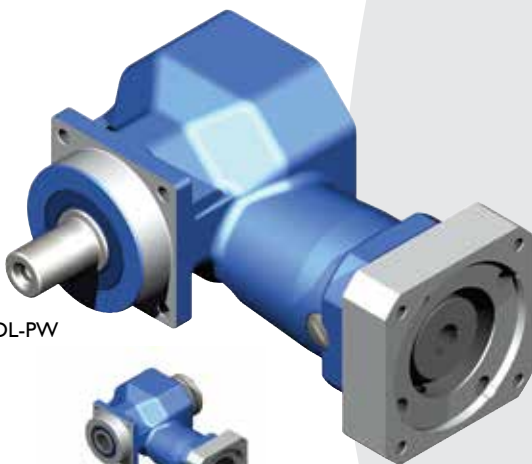

DL-PW

## DL-PW

- Single output shaft configuration with our high performance bellow coupling
- Input and housing to mount to any servo motor
- Ratios up to 15:1 in a single stage and 150:1 in two stages
- Frame sizes: 55, 75 and 90 mm
- Drop-in for many right-angle and in-line planetary gear reducers
- Rotation direction is opposite for DW and PW models.



DL-PH

## DL-PH (Contact GAM for availability)

- Smooth hollow output shaft configuration (includes shrink disc)

Sold & Serviced By (Available upon request)

 **ELECTROMATE**

Toll Free Phone (877) SERV098

Toll Free Fax (877) SERV099

www.electromate.com

sales@electromate.com



# ▶ DYNA-LITE SERIES - DL-D



Dyna-Lite Series			55	75	90
Stock Ratios			5, 10, 25, 50, 100, 150		
All Ratios Available*			1-stage: 5, 10, 15 2-stage: 25, 50, 100, 150* For other ratios, consult GAM.		
Nominal Output Torque ( $T_{2n}$ )	Nm (lb-in)	5:1, 10:1, 25:1, 50:1, 100:1	35 (310)	70 (620)	140 (1239)
		15:1, 150:1	25 (221)	50 (443)	90 (797)
Max Acceleration Output Torque ( $T_{2a}$ )	Nm (lb-in)	5:1, 10:1, 25:1, 50:1, 100:1	53 (469)	105 (929)	210 (1859)
		15:1, 150:1	38 (336)	75 (664)	143 (1266)
Emergency Output Torque ( $T_{2not}$ )	Nm (lb-in)	5:1, 10:1, 25:1, 50:1, 100:1	70 (620)	140 (1239)	280 (2478)
		15:1, 150:1	50 (443)	100 (885)	190 (1682)
Nominal Input Speed ( $n_{1n}$ )	RPM	5:1	3700	3100	2700
		10:1, 15:1	4200	3500	3000
		2-stage	3500	3000	3000
Max Input Speed ( $n_{1max}$ )	RPM		6000	6000	5000
Standard Output Backlash (j)	arcmin	1-stage	< 7	< 7	< 6
		2-stage	< 9	< 9	< 8
Allowable Radial Load ( $F_{rad}$ ) <sup>1)</sup>	N (lbs)		3300 (743)	4900 (1103)	7200 (1620)
Allowable Axial Load ( $F_{axial}$ )	N (lbs)		1650 (371)	2450 (551)	3600 (810)
Torsional Stiffness ( $C_{t21}$ )	Nm/arcmin		1.5	4.0	10.0
	(lb-in/arcmin)		(13.28)	(35.40)	(88.51)
Weight (m)	kg (lbs)	1-stage	2.6 (5.7)	4.5 (9.9)	9 (19.8)
		2-stage	3.6 (7.9)	6.8 (15)	14.8 (32.6)
Noise Level ( $L_{pA}$ )	dB(A)	1-stage	< 66	< 66	< 68
		2-stage	< 69	< 70	< 72
Mass Moment of Inertia ( $J_1$ )	kg cm <sup>2</sup> (lb-in <sup>2</sup> )	5:1	0.44 (0.15)	1.06 (0.36)	3.6 (1.224)
		10:1, 15:1	0.35 (0.119)	0.84 (0.286)	2.9 (0.986)
		25:1	0.17 (0.058)	0.45 (0.153)	1.65 (0.561)
		50:1, 100:1	0.14 (0.048)	0.34 (0.116)	1.1 (0.374)
Efficiency at Load		5,10: 96%	15: 93%	25,50,100,150: 87%	
Service Life		>15000 hours			
Lubrication		Life Time Lubrication			
Protection Rating		IP 64			
Operating Temperature Range		-10°C to 100°C (14°F to 212°F)			

1) Load applied at center of output shaft @100 RPM

\* other ratios available

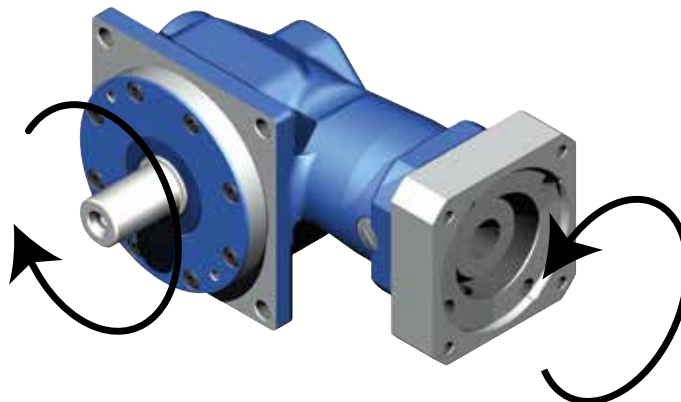

Sold & Serviced By:  
 ELECTROMATE

Toll Free Phone (877) SERV098

Toll Free Fax (877) SERV099

57 www.electromate.com

sales@electromate.com

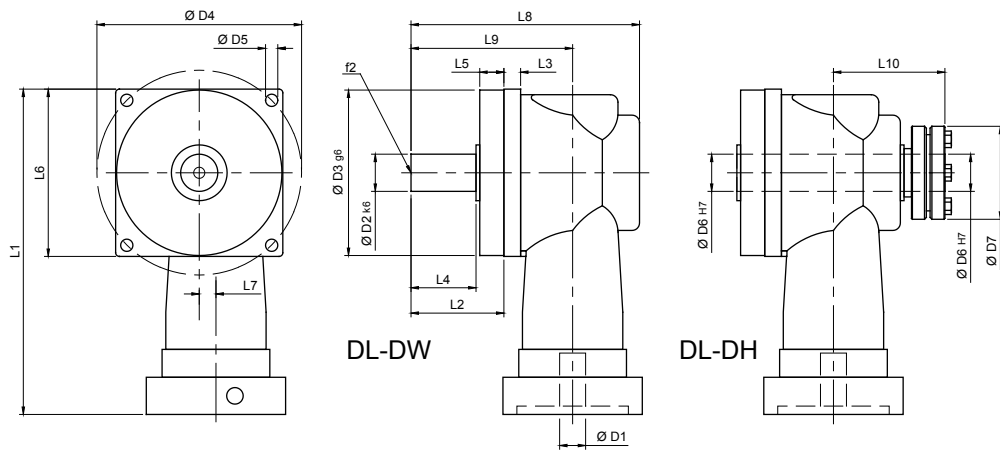

DL - DW and DL - DH		55		75		90	
		mm	(in)	mm	(in)	mm	(in)
D1 <sub>max (1 stage)*</sub>	motor shaft diameter	16	(0.63)	20	(0.787)	35	(1.378)
D1 <sub>max (2 stage standard)*</sub>	motor shaft diameter	14	(0.551)	19	(0.748)	19	(0.748)
D1 <sub>max (2 stage available)*</sub>	motor shaft diameter	16	(0.63)	24	(0.945)	24	(0.945)
D2 k6	output shaft diameter	20	(0.787)	24	(0.945)	32	(1.26)
D3 g6	pilot diameter	89	(3.504)	105	(4.134)	125	(4.921)
D4	bolt circle	110.3	(4.343)	138.6	(5.457)	166.8	(6.567)
D5	mounting holes	6.6	(0.26)	9	(0.354)	11	(0.433)
D6 H7**	hollow bore diameter	20	(0.787)	25	(0.984)	30	(1.181)
D7	shrink disc OD (included)	50	(1.97)	60	(2.36)	72	(2.83)
L1 1-stage***	gearbox length	175	(6.89)	213.5	(8.406)	257	(10.118)
L1 2-stage***		236	(9.291)	304.5	(11.99)	336	(13.23)
L2	shaft length	50.0	(1.969)	55	(2.165)	68	(2.677)
L3	flange thickness	9	(0.354)	11	(0.433)	14	(0.551)
L4	usable shaft length	35	(1.378)	40	(1.575)	50	(1.969)
L5	pilot height	13	(0.512)	13	(0.512)	16	(0.63)
L6	flange size	90	(3.543)	115	(4.528)	140	(5.512)
L7	gear offset	9	(0.354)	14	(0.551)	18	(0.709)
L8	gearbox width	123	(4.843)	142	(5.591)	175	(6.89)
L9	shaft to centerline	87	(3.425)	100	(3.937)	126	(4.961)
L10	shrink disc to centerline	64.5	(2.539)	73.5	(2.894)	87	(3.425)
f2	shaft thread per DIN332/1	M6 x 16		M8 x 19		M12 x 28	

\* for larger motor shaft diameters, please contact GAM \*\*mating shaft should have h6 tolerance \*\*\*depending on motor, length may vary



#### Recommended Output Coupling (if necessary)

metal bellows	KLC-50	KLC-125	KM-270
elastomer	EKC-80	EKC-110	EKM-300

#### TYPE CODES FOR DYNA-LITE SERIES (DL-D)

**Example: DL - DW - 075 - 005 H - [090 - 15A] - S111**

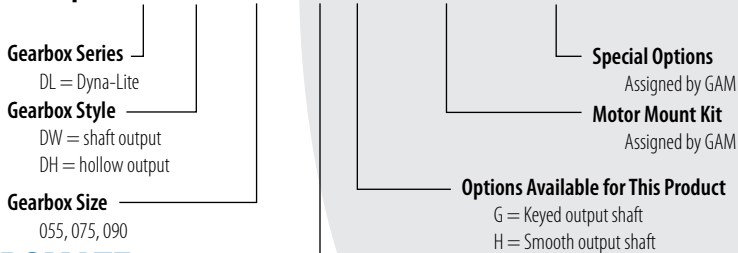

Size	Tolerances (mm)		
	k6	g6	H7
Over 18	+0.015	-0.007	+0.021
Thru 30	+0.002	-0.020	0
Over 30	+0.018	-0.009	+0.025
Thru 50	+0.002	-0.025	0
Over 50	+0.021	-0.010	+0.030
Thru 80	+0.002	-0.029	0
Over 80	+0.025	-0.012	+0.035
Thru 120	+0.003	-0.034	0
Over 120	+0.028	-0.014	+0.040
Thru 180	+0.003	-0.039	0



# ▶ DYNA-LITE SERIES - DL-P

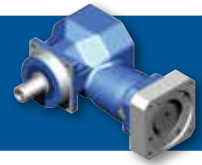

Dyna-Lite Series			55	75	90
Stock Ratios			5, 10, 25, 50, 100, 150		
All Ratios Available*			1-stage: 5, 10, 15 2-stage: 25, 50, 100, 150* For other ratios, consult GAM.		
Nominal Output Torque ( $T_{2n}$ )	Nm (lb-in)	5:1, 10:1, 25:1, 50:1, 100:1	35 (310)	70 (620)	140 (1239)
		15:1, 150:1	25 (221)	50 (443)	90 (797)
Max Acceleration Output Torque ( $T_{2a}$ )	Nm (lb-in)	5:1, 10:1, 25:1, 50:1, 100:1	53 (469)	105 (929)	210 (1859)
		15:1, 150:1	38 (336)	75 (664)	143 (1266)
Emergency Output Torque ( $T_{2not}$ )	Nm (lb-in)	5:1, 10:1, 25:1, 50:1, 100:1	70 (620)	140 (1239)	280 (2478)
		15:1, 150:1	50 (443)	100 (885)	190 (1682)
Nominal Input Speed ( $n_{1n}$ )	RPM	5:1	3700	3100	2700
		10:1, 15:1	4200	3500	3000
		2-stage	3500	3000	3000
Max Input Speed ( $n_{1max}$ )	RPM		6000	6000	5000
Standard Output Backlash (j)	arcmin	1-stage	< 7	< 7	< 6
		2-stage	< 9	< 9	< 8
Allowable Radial Load ( $F_{rad}$ ) <sup>1)</sup>	N (lbs)		2200 (495)	4050 (911)	6200 (1395)
Allowable Axial Load ( $F_{axial}$ )	N (lbs)		1100 (248)	2025 (456)	3100 (698)
Torsional Stiffness ( $C_{21}$ )	Nm/arcmin		1.5	4.0	10.0
	(lb-in/arcmin)		(13.28)	(35.40)	(88.51)
Weight (m)	kg (lbs)	1-stage	2.6 (5.7)	4.5 (9.9)	9 (19.8)
		2-stage	3.6 (7.9)	6.8 (15)	14.8 (32.6)
Noise Level ( $L_{pA}$ )	dB(A)	1-stage	< 66	< 66	< 68
		2-stage	< 69	< 70	< 72
Mass Moment of Inertia ( $J_1$ )	kg cm <sup>2</sup> (lb-in <sup>2</sup> )	5:1	0.44 (0.15)	1.08 (0.37)	3.7 (1.258)
		10:1, 15:1	0.35 (0.119)	0.84 (0.286)	2.9 (0.986)
		25:1	0.17 (0.058)	0.45 (0.153)	1.65 (0.561)
		50:1, 100:1	0.14 (0.048)	0.34 (0.116)	1.1 (0.374)
Efficiency at Load		5,10: 96%	15: 93%	25,50,100,150: 87%	
Service Life		>15000 hours			
Lubrication		Life Time Lubrication			
Protection Rating		IP 64			
Operating Temperature Range		-10°C to 100°C (14°F to 212°F)			

1) Load applied at center of output shaft @100 RPM

\* other ratios available

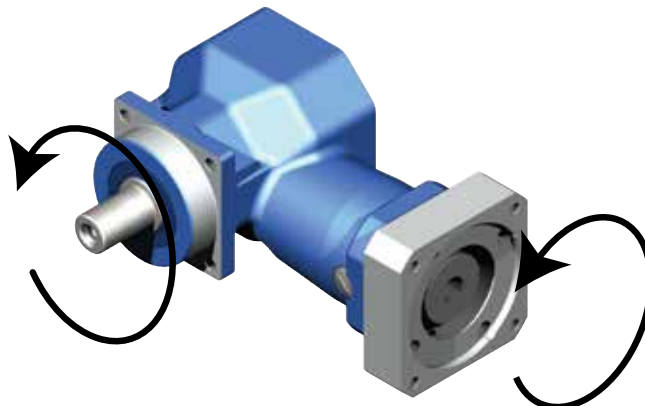

Sold & Serviced By:

Toll Free Phone (877) SERV098  
 Toll Free Fax (877) SERV099  
 59 www.electromate.com  
 sales@electromate.com

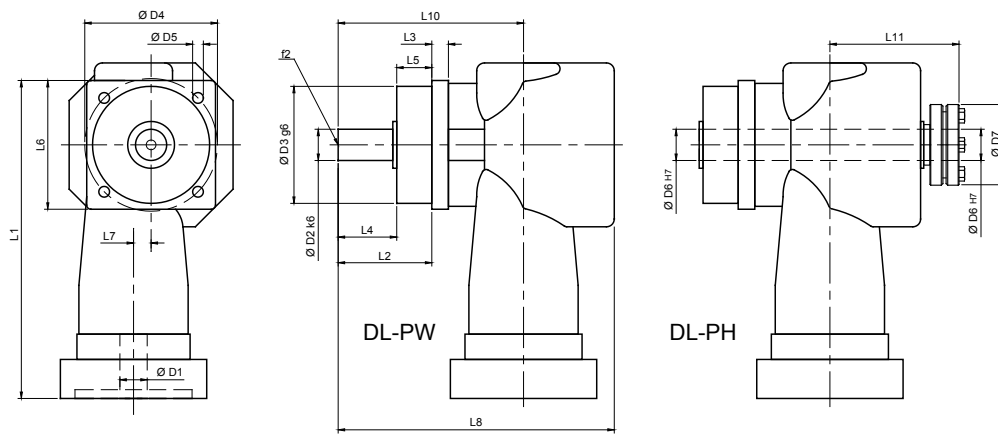

DL - PW and DL - PH		55		75		90	
		mm	(in)	mm	(in)	mm	(in)
D1 <sub>max</sub> (1 stage)*	motor shaft diameter	16	(0.63)	20	(0.787)	35	(1.378)
D1 <sub>max</sub> (2 stage standard)*	motor shaft diameter	14	(0.551)	19	(0.748)	19	(0.748)
D1 <sub>max</sub> (2 stage available)*	motor shaft diameter	16	(0.63)	24	(0.945)	24	(0.945)
D2 k6	output shaft diameter	16	(0.63)	22	(0.866)	32	(1.26)
D3 g6	pilot diameter	60	(2.362)	70	(2.756)	90	(3.543)
D4	bolt circle	68	(2.677)	85	(3.346)	120	(4.724)
D5	mounting holes	5.5	(0.217)	6.6	(0.26)	9	(0.354)
D6 H7**	hollow bore diameter	15	(0.591)	20	(0.787)	30	(1.181)
D7	shrink disc OD (included)	44	(1.732)	50	(1.969)	72	(2.835)
L1 1-stage***	gearbox length	172	(6.772)	206	(8.11)	249.5	(9.823)
L1 2-stage***		236	(9.291)	304.5	(11.99)	336	(13.23)
L2	shaft length	48.0	(1.89)	56	(2.205)	80	(3.15)
L3	flange thickness	8.5	(0.335)	10	(0.394)	13	(0.512)
L4	usable shaft length	28	(1.102)	36	(1.417)	58	(2.283)
L5	pilot height	18	(0.709)	18	(0.709)	20	(0.787)
L6	flange size	66	(2.598)	76	(2.992)	101	(3.976)
L7	gear offset	9	(0.354)	14	(0.551)	18	(0.709)
L8	gearbox width	141.5	(5.571)	166	(6.535)	216	(8.504)
L10	shaft to centerline	95	(3.740)	110	(4.331)	148	(5.827)
L11	shrink disc to centerline	estimated 70	(2.756)	estimated 86	(3.386)	estimated 108	(4.252)
F2	shaft thread per DIN332/1	M6 x 16		M8 x 19		M12x28	

\* for larger motor shaft diameters, please contact GAM \*\*mating shaft should have h6 tolerance \*\*\*depending on motor, length may vary

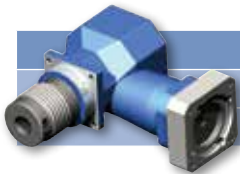

#### Recommended Output Coupling (if necessary)

metal bellows	KLC-50	KLC-125	KM-270
elastomer	EKC-80	EKC-110	EKM-300

#### TYPE CODES FOR DYNA-LITE SERIES (DL-P)

**Example: DL - PW - 075 - 005 H - [090 - 15A] - S111**

**Gearbox Series**

DL = Dyna-Lite

**Gearbox Style**

PW = shaft output

PH = hollow output

**Gearbox Size**

055, 075, 090

**Special Options**

Assigned by GAM

**Motor Mount Kit**

Assigned by GAM

**Options Available for This Product**

G = Keyed output shaft

H = Smooth output shaft

Size	Tolerances (mm)		
	k6	g6	H7
Over 18	+0.015	-0.007	+0.021
Thru 30	+0.002	-0.020	0
Over 30	+0.018	-0.009	+0.025
Thru 50	+0.002	-0.025	0
Over 50	+0.021	-0.010	+0.030
Thru 80	+0.002	-0.029	0
Over 80	+0.025	-0.012	+0.035
Thru 120	+0.003	-0.034	0
Over 120	+0.028	-0.014	+0.040
Thru 180	+0.003	-0.039	0

Sold & Serviced By:

**ELECTROMATE**

Toll Free Phone (877) SERV098

Toll Free Fax (877) SERV099

www.electromate.com

sales@electromate.com



## ▶ PERFORMANCE: SPIRAL BEVEL SERIES

### GAM can.

If you don't see exactly what you need, let us know. We can modify the VC Series gearboxes to meet your needs. Page 4 provides a list of commonly requested modifications to give you a feel for our capabilities.

### GAM Spiral Bevel Gearboxes

When you need a spiral bevel gearbox that you can count on, choose GAM. Our spiral bevel gearboxes are highly configurable, reliable, and economical right angle solutions designed for use in a wide range of applications. Precision cut spiral bevel gears are hardened and then lapped in pairs for ideal tooth contact and torque transmission, enabling 94-98% efficiencies and backlash between 10 and 30 arcmin (Reduced backlash versions available). Offered in 11 frame sizes, they can be constructed with a multitude of shaft configurations, and oriented in any direction to easily incorporate into your machine design.

### VC spiral bevel series shown with integrated motor mount.

- High efficiencies 94-98%
- Lubricated for life with synthetic oil
- Includes motor mount

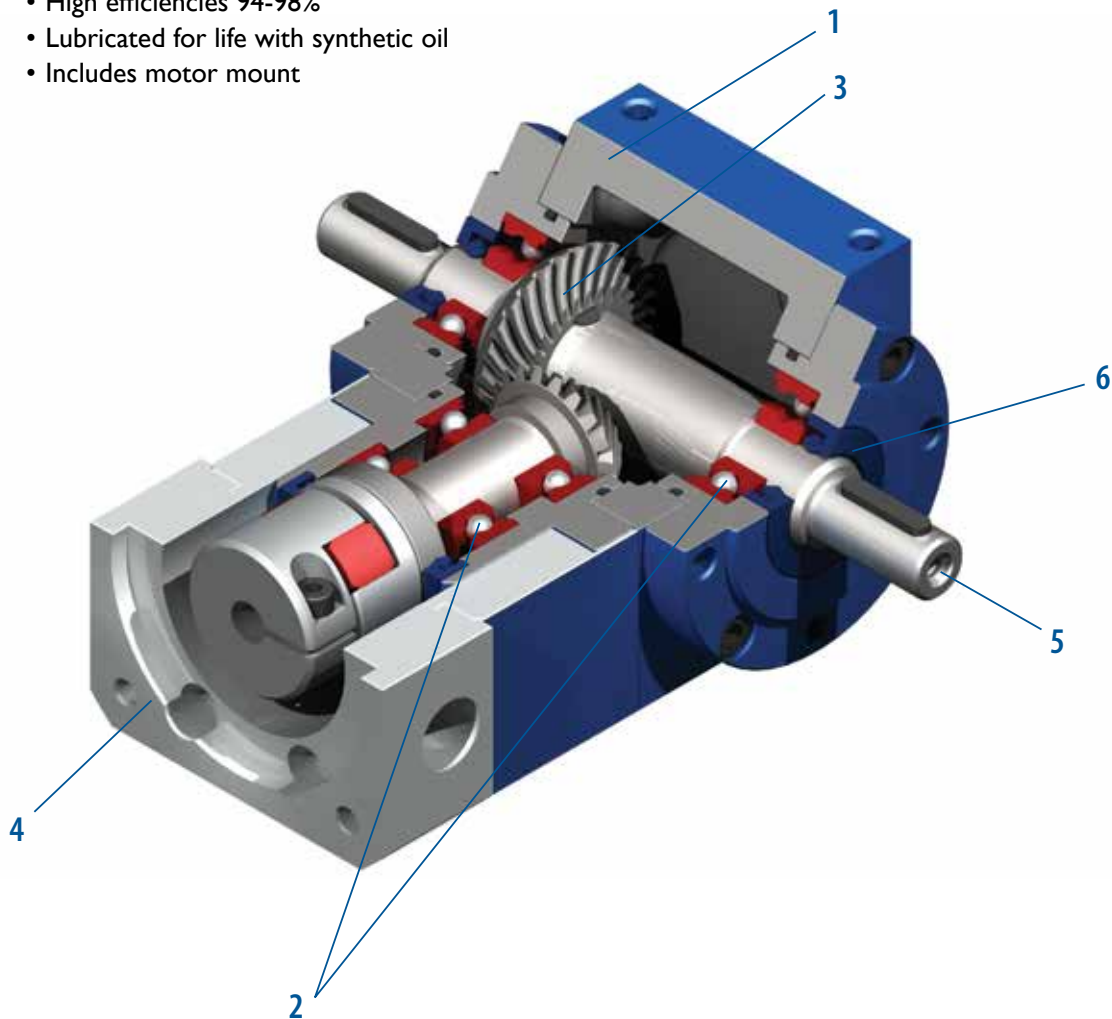

#### 1. Housing

Sturdy cast iron housing  
(Aluminum in size 35mm and 45mm)  
- all 6 sides can be used for mounting

#### 2. Bearings

Deep groove ball bearings handle axial and radial loading. (Reinforced and taper roller options available)

#### 3. Spiral Bevel Gearing

Precision cut, hardened, and lapped in pairs for ideal tooth contact. Mathematically precise ratios from 1:1 to 6:1

#### 4. Input

Available with shaft input or integrated motor adapter and coupling to easily mount to any IEC, NEMA, or servo motor

#### 5. Output

Solid shaft with key or keyed hollow shaft are standard. (Smooth shaft or shrink disc clamping available)

#### 6. Seals

Lubricated for life and protected with high quality NBR seals. (Viton® and FPM seals available)

Sold & Serviced By:

 **ELECTROMATE**

Toll Free Phone (877) SERV098

Toll Free Fax (877) SERV099

61 [www.electromate.com](http://www.electromate.com)  
[sales@electromate.com](mailto:sales@electromate.com)

## Shaft Input

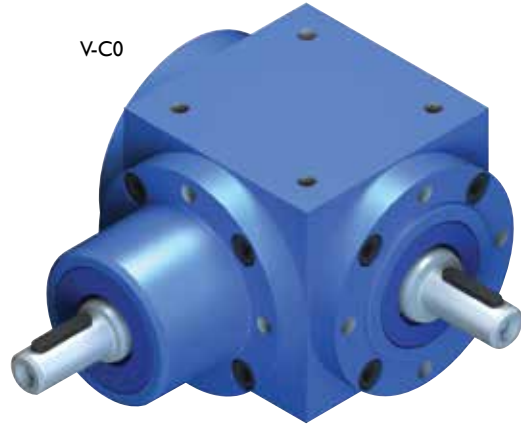

V-C0

**V-Series**  
(65mm to 350mm)



L-C0

**L-Series**  
("mini" 35mm & 45mm)

### Available Models

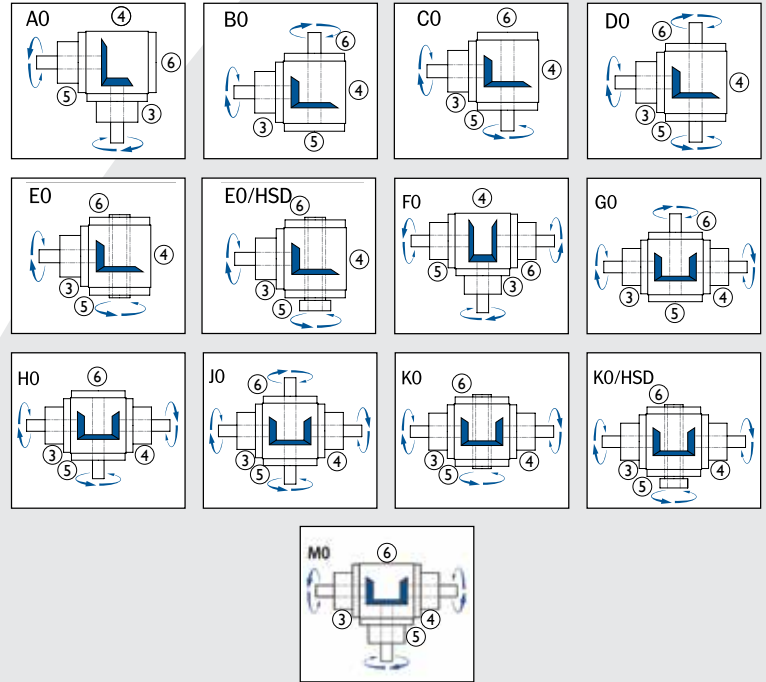

## Integrated Motor Mount Input

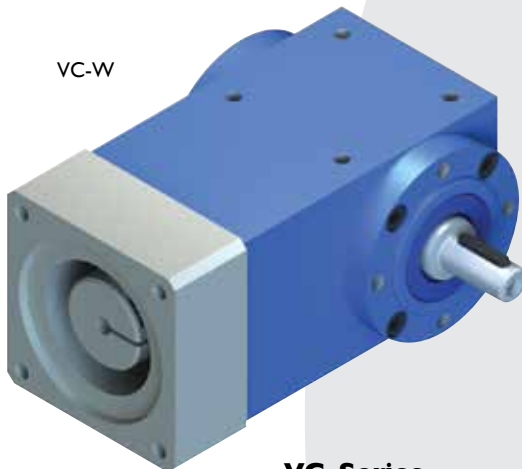

VC-W

**VC-Series**  
(65mm to 200mm)



LL-W

**LL-Series**  
("mini" 35mm & 45mm)

### Available Models

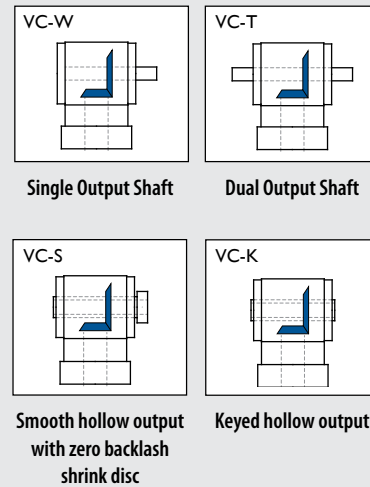

Sold & Serviced By:

 **ELECTROMATE**

Toll Free Phone (877) SERV098

Toll Free Fax (877) SERV099

www.electromate.com

sales@electromate.com



# V SERIES & L SERIES

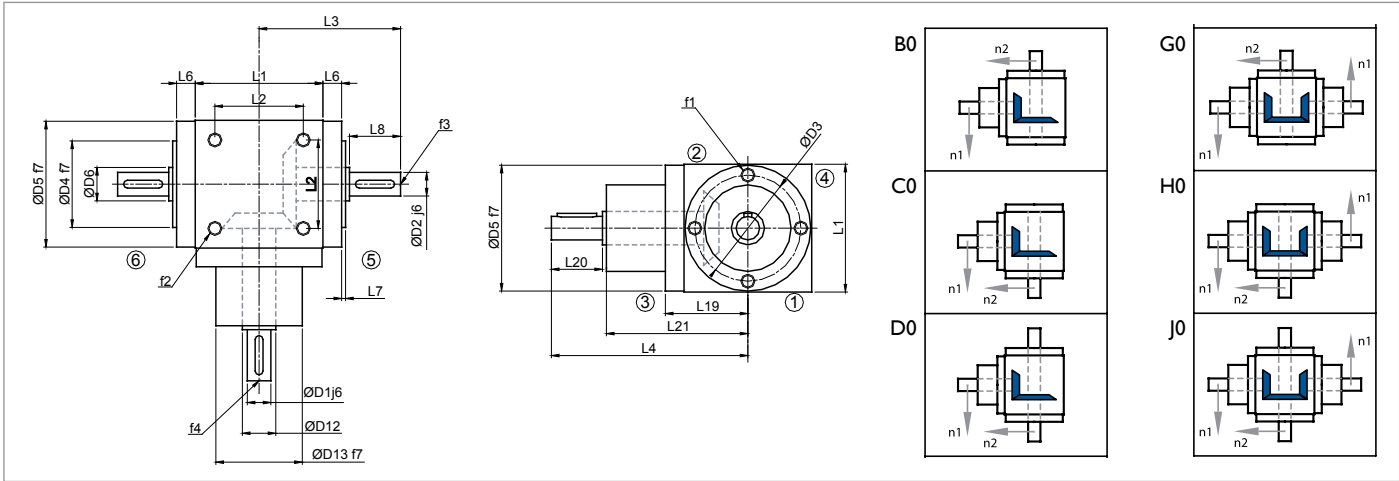

Dimension	Model Description	L-Series										V-Series								
		035		045				065				090				120				
		mm		mm				mm				mm				mm				
Major Dimensions (Applies to all models)	D3	Bolt Circle		29	39	54				75				100						
	D4 f7	Small Pilot Diameter		22	32	44				60				80						
	D5 f7	Pilot Diameter		35	45	64				89				119						
	f2	Housing Thread		M3x8	M4x8	M6x12				M8x14				M10x16						
	L1	Housing Size		35	45	65				90				120						
	L2	Housing Bolt Location		25	30	45				70				100						
	L19	Centerline to Input Pilot		23	30.5	42				55				75						
Input Dimensions that change based on ratio	-	Ratio		1:1	1:1 - 2:1	3:1	4:1	5:1 - 6:1	1:1 - 2:1	3:1	4:1	5:1 - 6:1	1:1 - 2:1	3:1	4:1	5:1 - 6:1	1:1 - 2:1	3:1	4:1	5:1 - 6:1
	D1 j6	Input Shaft Diameter		6	10	10	10	-	12	12	-	-	18	12	12	12	25	20	20	15
	-	Input Shaft Key Width		2	3	3	3	-	4	4	-	-	6	4	4	4	8	6	6	5
	-	Input Shaft Key Length		10	18	18	18	-	20	20	-	-	28	28	28	28	36	36	36	28
	-	Input Shaft Key Height		0.9	1.2	1.2	1.2	-	1.5	1.5	-	-	2.5	1.5	1.5	1.5	3	2.5	2.5	2
	D12	Input Shaft Diameter		10	15	15	15	-	17	17	-	-	25	20	20	20	30	25	25	20
	D13 f7	Input Hub Pilot Diameter		22	32	32	32	-	44	44	-	-	60	60	60	60	80	80	80	70
	f4	Input Shaft Thread (DIN 332)		M3	M3	M3	M3	-	M4	M4	-	-	M6	M4	M4	M4	M10	M6	M6	M5
	L4	Centerline to End of Input Shaft		59	78	78	78	-	100	100	-	-	122	122	132	132	162	162	172	162
	L20	Input Shaft Length		15	23	23	23	-	26	26	-	-	35	35	35	35	45	45	45	35
L21	Centerline to Input Hub		43	53	53	53	-	72	72	-	-	85	85	95	95	115	115	125	125	
Applies to models B0, C0, D0, G0, H0, J0	D2 j6	Output Shaft Diameter		6	10				12				18				25			
	-	Output Shaft Key Width		2	3				4				6				8			
	-	Output Shaft Key Length		10	18				20				28				36			
	-	Output Shaft Key Height		0.9	1.2				1.5				2.5				3			
	D6	Output Step Diameter		10	15				17				30				35			
	f1	Output Flange Thread		M3x5	M4x8				M6x9.5				M8x10				M10x12			
	f3	Output Shaft Thread (DIN 332)		M3	M3				M4				M6				M10			
	L3	Output Shaft to Centerline		40	57.5				72				95				122			
	L6	Pilot Height		5.5	8				9.5				10				12			
	L7	Small Pilot Height		1.5	2				2				2				3			
Applies to models A0, F0, M0	D2 j6	Output Shaft Diameter		6	10				12				18				25			
	-	Output Shaft Key Width		2	3				4				6				8			
	-	Output Shaft Key Length		10	18				20				28				36			
	-	Output Shaft Key Height		0.9	1.2				1.5				2.5				3			
	D6	Output Step Diameter		10	15				17				30				30			
	D15 f7	Output Hub Pilot Diameter		22	32				44				60				80			
	f1	Output Flange Thread		M3x5	M4x8				M6x9.5				M8x10				M10x15			
	f3	Output Shaft Thread (DIN 332)		M3	M3				M4				M6				M10			
	L3	Output Shaft to Centerline		59	78				100				122				162			
	L6	Pilot Height		5.5	8				9.5				10				15			
L8	Output Shaft Length		15	23				26				35				45				

Sold & Serviced By:



Toll Free Phone (877) SERV098

Toll Free Fax (877) SERV099

63 www.electromate.com

sales@electromate.com

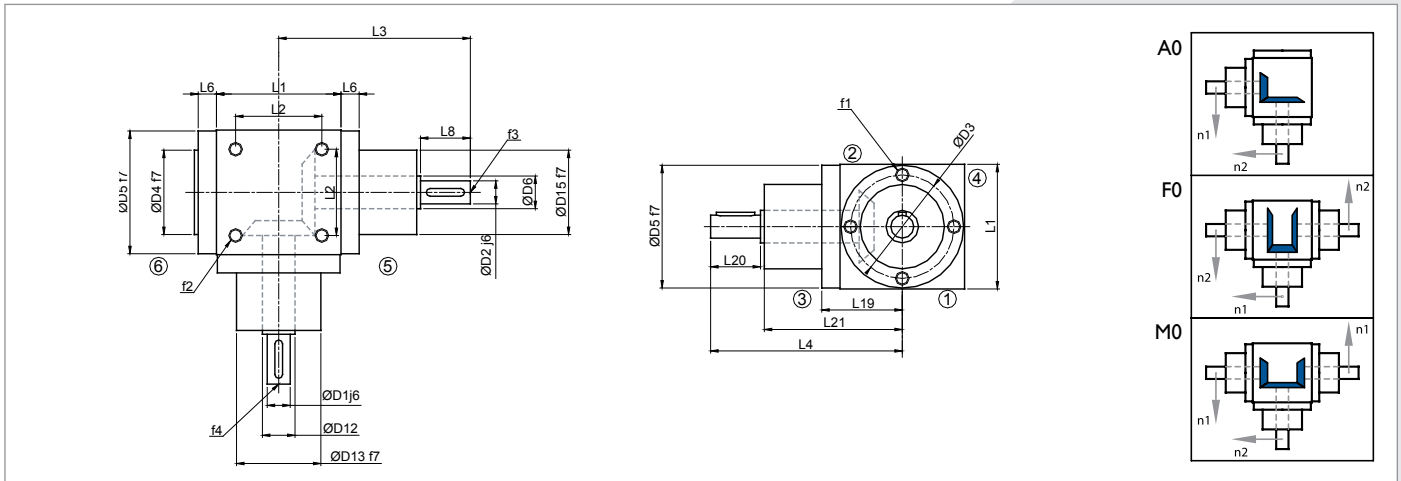

Dimension		V-Series																											
		140				160				200				230				260				350							
		mm				mm				mm				mm				mm				mm							
Major Dimensions (Applies to all models)	D3	115				135				175				200				230				260				305*			
	D4 f7	90				110				120				150				160				250							
	D5 f7	135				159				199				225				255				345							
	f2	M10x20				M12x24				M12x24				M16x20				M16x32				M20x26**							
	L1	140				160				200				230				260				350							
	L2	110				120				160				180				220				285							
	L19	85				95				120				135				150				198							
Input Dimensions that change based on ratio	-	1:1 - 2:1	3:1	4:1	5:1 - 6:1	1:1 - 2:1	3:1	4:1	5:1 - 6:1	1:1 - 2:1	3:1	4:1	5:1 - 6:1	1:1 - 2:1	3:1	4:1	5:1 - 6:1	1:1 - 2:1	3:1	4:1	5:1 - 6:1	1:1 - 2:1	3:1	4:1	5:1 - 6:1				
	D1 j6	32	28	24	24	35	28	24	24	42	35	35	28	55	40	40	35	60	45	45	45	80	65	65	55				
	-	10	8	8	8	10	8	8	8	12	10	10	8	16	12	12	10	18	14	14	14	22	18	18	16				
	-	45	45	45	45	50	50	50	50	70	63	63	63	80	70	70	63	100	80	80	80	160	125	125	90				
	-	3	3	3	3	3	3	3	3	3	3	3	3	2.5	3	3	3	4	3.5	3.5	3.5	5	4	4	4				
	D12	40	40	40	40	40	40	40	40	55	40	40	40	30	60	50	50	45	65	65	65	90	90	90	72				
	D13 f7	90	90	85	85	110	100	100	100	120	120	120	110	150	140	140	140	160	160	160	160	250	250	250	250				
	f4	M12	M10	M8	M8	M12	M10	M8	M8	M16	M12	M12	M10	M20	M16	M16	M16	M20	M16	M16	M16	M20	M20	M20	M20				
	L4	180	180	195	195	212	212	232	232	273	261	261	261	305	310	310	300	380	360	360	360	570	540	540	510				
	L20	50	50	50	50	60	60	60	60	80	68	68	68	90	80	80	70	110	90	90	90	170	140	140	110				
L21	128	128	143	143	150	150	170	170	190	190	190	190	213	228	228	228	265	265	265	265	395	395	395	395					
Applies to models B0, C0, D0, G0, H0, J0	D2 j6	32				35				42				55				60				80							
	-	10				10				12				16				18				22							
	-	45				50				70				80				100				160							
	-	3				3				3				4				4				5							
	D6	50				40				55				60				65				90							
	f1	M10x12				M12x15				M12x17				M16x17				M16x20				M20x30							
	f3	M12				M12				M16				M20				M20				M20							
	L3	137				160				203				230				268				410							
	L6	12				15				17				17				20				30							
	L7	3				3				3				4				4				20							
Applies to models A0, F0, M0	D2 j6	32				35				42				55				60				80							
	-	10				10				12				16				18				22							
	-	45				50				70				80				100				160							
	-	3				3				3				4				4				5							
	D6	40				40				55				60				65				90							
	D15 f7	90				110				120				150				160				250							
	f1	M10x15				M12x15				M12x20				M16x20				M16x20				-							
	f3	M12				M12				M16				M20				M20				M20							
	L3	180				212				273				305				380				570							
	L8	15				15				20				20				20				23							
L8	50				60				80				90				110				170								



# V SERIES & L SERIES

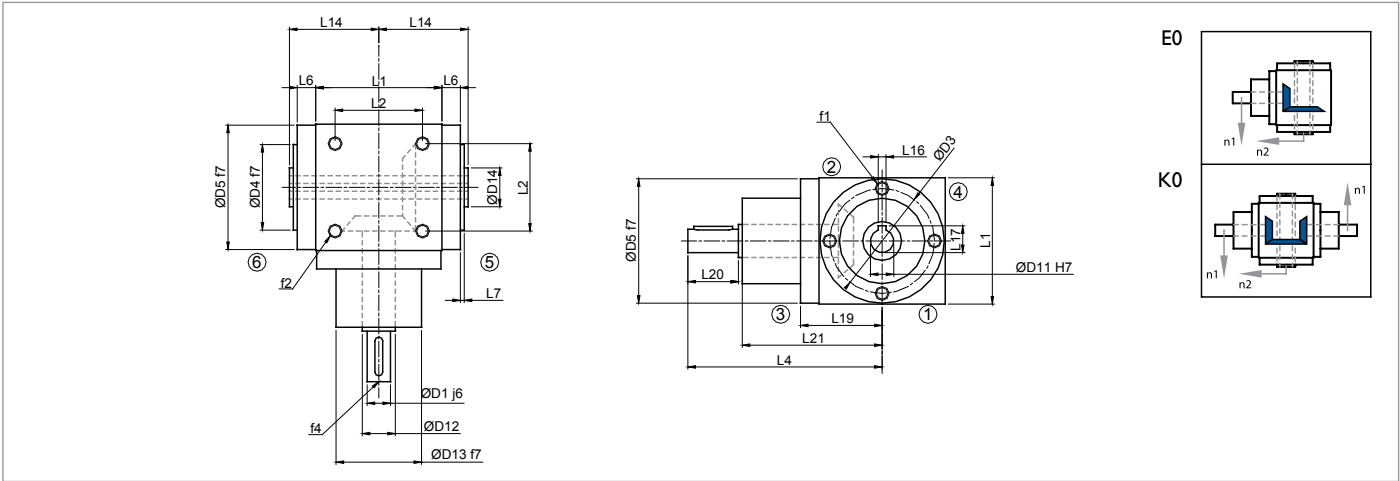

Dimension	Model Description	L-Series						V-Series										
		035 mm	045 mm			065 mm	090 mm			120 mm								
Major Dimensions (Applies to all models)	D3 Bolt Circle	29	39			54	75			100								
	D4 f7 Small Pilot Diameter	22	32			44	60			80								
	D5 f7 Pilot Diameter	35	45			64	89			119								
	f2 Housing Thread	M3x8	M4x8			M6x12	M8x14			M10x16								
	L1 Housing Size	35	45			65	90			120								
	L2 Housing Bolt Location	25	30			45	70			100								
	L19 Centerline to Input Pilot	23	30.5			42	55			75								
Input Dimensions that change based on ratio	- Ratio	1:1	1:1 - 2:1	3:1	4:1	5:1 - 6:1	1:1 - 2:1	3:1	4:1	5:1 - 6:1	1:1 - 2:1	3:1	4:1	5:1 - 6:1	1:1 - 2:1	3:1	4:1	5:1 - 6:1
	D1 j6 Input Shaft Diameter	6	10	10	10	-	12	12	-	-	18	12	12	12	25	20	20	15
	- Input Shaft Key Width	2	3	3	3	-	4	4	-	-	6	4	4	4	8	6	6	5
	- Input Shaft Key Length	10	18	18	18	-	20	20	-	-	28	28	28	28	36	36	36	28
	- Input Shaft Key Height	0.9	1.2	1.2	1.2	-	1.5	1.5	-	-	2.5	1.5	1.5	1.5	3	2.5	2.5	2
	D12 Input Step Diameter	10	15	15	15	-	17	17	-	-	25	20	20	20	30	25	25	20
	D13 f7 Input Hub Pilot Diameter	22	32	32	32	-	44	44	-	-	60	60	60	60	80	80	80	70
	f4 Input Shaft Thread (DIN 332)	M3	M3	M3	M3	-	M4	M4	-	-	M6	M4	M4	M4	M10	M6	M6	M5
	L4 Centerline to End of Input Shaft	59	78	78	78	-	100	100	-	-	122	122	132	132	162	162	172	162
	L20 Input Shaft Length	15	23	23	23	-	26	26	-	-	35	35	35	35	45	45	45	35
L21 Centerline to Input Hub	43	53	53	53	-	72	72	-	-	85	85	95	95	115	115	125	125	
Applies to models E0 and K0	D11 H7 Hollow Shaft Diameter	6	10				12				18			25				
	D14 Extended Shaft Diameter	10	15				20				30			40				
	f1 Output Flange Thread	M3x5	M4x8				M6x9.5				M8x10			M10x12				
	L6 Pilot Height	5.5	8				9.5				10			12				
	L7 Small Pilot Height	1.5	2				2				2			3				
	L14 Hollow Shaft to Centerline	26.5	34.5				46				62			80				
	L16 JS9 Hollow Shaft Key Width	2	3				4				6			8				
Applies to models E0/HSD, K0/HSD	L17 Hollow Shaft Height with Keyway	7	11.4				13.8				20.8			28.3				
	D7 H6 *** Smooth Hollow Shaft Diameter 1	-	-				12				18			25				
	D8 Opened up inner Diameter	-	-				13				19			26				
	D9 H7 **** Smooth Hollow Shaft Diameter 2	-	-				14				20			27				
	D10 Shrink Disc OD	-	-				38				50			60				
	D14 Extended Shaft Diameter	-	-				20				30			40				
	f1 Output Flange Thread	-	-				M6x9.5				M8x10			M10x12				
	L6 Pilot Height	-	-				9.5				10			12				
	L7 Small Pilot Height	-	-				2				2			3				
	L12 Stub Shaft Length	-	-				15				18			22				
	L13 Hollow Bore 1 Depth 1	-	-				25				28			32				
L14 Hollow Shaft to Centerline	-	-				46				62			80					
L14 Shrink Disc to Centerline	-	-				63				87			107					

Sold & Serviced By:



\*\*\*Mating shafts should have j6 tolerance  
 \*\*\*\*Mating shaft should have h6 tolerance

65 www.electromate.com  
 sales@electromate.com

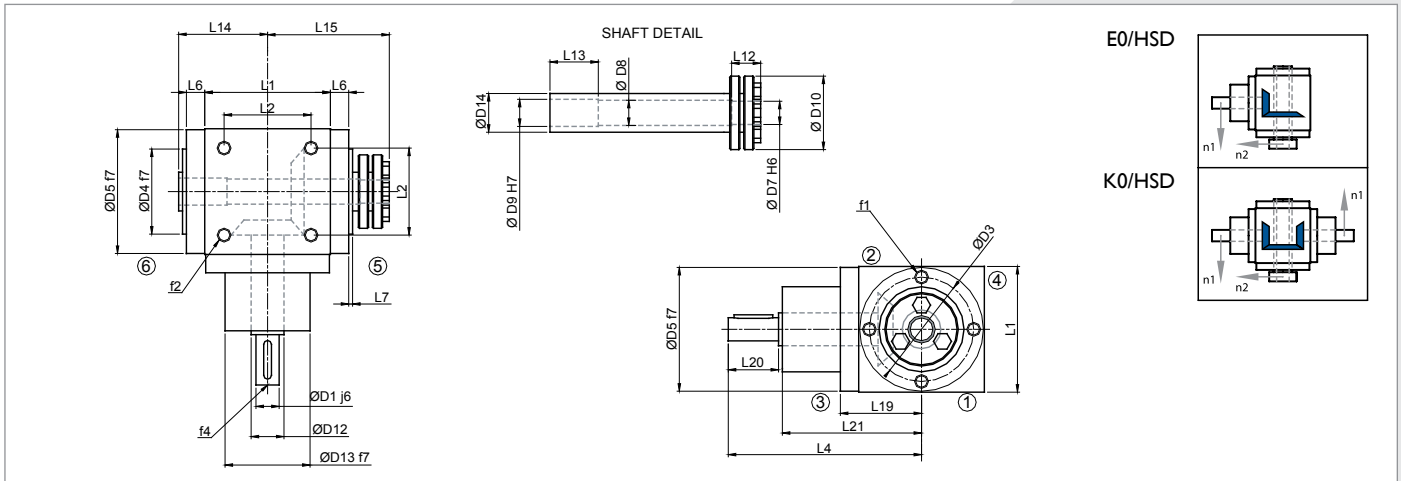

Major Dimensions (Applies to all models)	V-Series																								
	140		160		200		230		260		350		140		160		200		230		260		350		
Dimension	mm		mm		mm		mm		mm		mm		mm		mm		mm		mm		mm		mm		
D3	115		135		175		200		230		260		305*		115		135		175		200		250		
D4 f7	90		110		120		150		160		160		250		90		110		120		150		250		
D5 f7	135		159		199		225		255		345		135		159		199		225		255		345		
f2	M10x20		M12x24		M12x24		M16x20		M16x32		M20x26**		M10x20		M12x24		M12x24		M16x20		M16x32		M20x26**		
L1	140		160		200		230		260		350		140		160		200		230		260		350		
L2	110		120		160		180		220		285		110		120		160		180		220		285		
L19	85		95		120		135		150		198		85		95		120		135		150		198		
Input Dimensions that change based on ratio	-	1:1 - 2:1	3:1	4:1	5:1 - 6:1	1:1 - 2:1	3:1	4:1	5:1 - 6:1	1:1 - 2:1	3:1	4:1	5:1 - 6:1	1:1 - 2:1	3:1	4:1	5:1 - 6:1	1:1 - 2:1	3:1	4:1	5:1 - 6:1	1:1 - 2:1	3:1	4:1	5:1 - 6:1
	D1 j6	32	28	24	24	35	28	24	24	42	35	35	28	55	40	40	35	60	45	45	45	80	65	65	55
	-	10	8	8	8	10	8	8	8	12	10	10	8	16	12	12	10	18	14	14	14	22	18	18	16
	-	45	45	45	45	50	50	50	50	70	63	63	63	80	70	70	63	100	80	80	80	160	125	125	90
	-	3	3	3	3	3	3	3	3	3	3	3	3	2.5	3	3	3	4	3.5	3.5	3.5	5	4	4	4
	D12	40	40	40	40	40	40	40	40	55	40	40	30	60	50	50	45	65	65	65	65	90	90	90	72
	D13 f7	90	90	85	85	110	100	100	100	120	120	120	110	150	140	140	140	160	160	160	160	250	250	250	250
	f4	M12	M10	M8	M8	M12	M10	M8	M8	M16	M12	M12	M10	M20	M16	M16	M16	M20	M16	M16	M16	M20	M20	M20	M20
	L4	180	180	195	195	212	212	232	232	273	261	261	261	305	310	310	300	380	360	360	360	570	540	540	510
L20	50	50	50	50	60	60	60	60	80	68	68	68	90	80	80	70	110	90	90	90	170	140	140	110	
L21	128	128	143	143	150	150	170	170	190	190	190	190	213	228	228	228	265	265	265	265	395	395	395	395	
Applies to models E0 and K0	D11 H7	32		35		42		55		60		80		80		105		80		105		80		105	
	D14	50		55		70		80		80		105		80		105		80		105		80		105	
	f1	M10x12		M12x15		M12x17		M16x17		M16x20		M20x30		M10x12		M12x15		M12x17		M16x17		M16x20		M20x30	
	L6	12		15		17		17		20		30		12		15		17		17		20		30	
	L7	3		3		3		4		4		20		3		3		4		4		20		30	
	L14	90		103		125		142.5		160		240		90		103		125		142.5		160		240	
	L16 JS9	10		10		12		16		18		22		10		10		12		16		18		22	
L17	35.3		38.3		45.3		59.3		64.4		85.4		35.3		38.3		45.3		59.3		64.4		85.4		
Applies to models E0/HSD5, K0/HSD5	D7 H6***	32		35		42		55		60		80		32		35		42		55		60		80	
	D8	33		36		43		56		61		81		33		36		43		56		61		81	
	D9 H7****	34		37		44		57		62		82		34		37		44		57		62		82	
	D10	80		80		100		138		138		170		80		80		100		138		138		170	
	D14	50		55		70		80		80		105		50		55		70		80		80		105	
	f1	M10x12		M12x15		M12x17		M16x17		M16x20		M20x30		M10x12		M12x15		M12x17		M16x17		M16x20		M20x30	
	L6	12		15		17		17		20		30		12		15		17		17		20		30	
	L7	3		3		3		4		4		20		3		3		4		4		20		30	
	L12	25		25		35		40		40		45		25		25		35		40		40		45	
	L13	40		40		55		60		60		65		40		40		55		60		60		65	
L14	90		103		125		142.5		160		240		90		103		125		142.5		160		240		
L15	122		135		162		182.5		200		293		122		135		162		182.5		200		293		



# V SERIES & L SERIES

Ratio	Model Size	L-Series				V-Series					
		035		045		065		090		120	
		Input Speed (RPM)	Output Torque (Nm)	Power (kW)	Output Torque (Nm)	Power (kW)	Output Torque (Nm)	Power (kW)	Output Torque (Nm)	Power (kW)	Output Torque (Nm)
1:1	50	4.5	0.025	9	0.05	18	0.1	50	0.28	130	0.72
	250	4.5	0.124	9	0.248	17	0.47	44	1.21	123	3.39
	500	4	0.22	8	0.441	15	0.83	40	2.2	115	6.34
	750	3.6	0.298	7.3	0.603	13	1.07	37	3.06	103	8.51
	1000	3.5	0.386	7	0.772	12	1.32	34	3.75	92	10.14
	1500	3	0.496	6	0.992	11	1.82	32	5.29	82	13.56
	2400	2.4	0.635	4.5	1.19	10	2.65	28	7.41	70	18.52
1.5:1	50	-	-	-	-	18	0.07	45	0.16	113	0.41
	250	-	-	-	-	17	0.31	40	0.74	108	1.99
	500	-	-	-	-	15	0.55	37	1.36	105	3.85
	750	-	-	-	-	13	0.72	35	1.93	94	5.18
	1000	-	-	-	-	12	0.88	32	2.35	86	6.32
	1500	-	-	-	-	11	1.21	29	3.2	78	8.6
	2400	-	-	-	-	10	1.76	26	4.59	65	11.46
2:1	50	-	-	7	0.019	18	0.05	37	0.1	107	0.29
	250	-	-	6.5	0.09	17	0.23	36	0.5	98	1.35
	500	-	-	6	0.165	15	0.41	34	0.94	92	2.54
	750	-	-	5.7	0.236	13	0.54	32	1.32	86	3.55
	1000	-	-	5.5	0.303	12	0.66	31	1.71	81	4.46
	1500	-	-	5	0.413	11	0.91	27	2.23	73	6.03
	2400	-	-	4.75	0.628	10	1.32	24	3.17	61	8.07
3:1	50	-	-	5.5	0.01	14	0.03	37	0.07	110	0.21
	250	-	-	5	0.046	13	0.12	36	0.33	95	0.87
	500	-	-	4.5	0.083	13	0.24	34	0.63	90	1.66
	750	-	-	4.2	0.116	12	0.33	32	0.88	87	2.4
	1000	-	-	4	0.147	12	0.44	31	1.14	82	3.01
	1500	-	-	3.5	0.193	11	0.61	27	1.49	74	4.08
	2400	-	-	3.4	0.3	10	0.88	24	2.12	63	5.56
4:1	50	-	-	4.5	0.006	-	-	37	0.05	90	0.12
	250	-	-	4.5	0.031	-	-	36	0.25	87	0.6
	500	-	-	4.25	0.059	-	-	34	0.47	84	1.16
	750	-	-	4.2	0.087	-	-	32	0.66	82	1.69
	1000	-	-	4	0.11	-	-	31	0.85	79	2.18
	1500	-	-	3.75	0.155	-	-	27	1.12	74	3.06
	2400	-	-	3.6	0.238	-	-	25	1.65	67	4.43
5:1	50	-	-	-	-	-	-	37	0.04	95	0.1
	250	-	-	-	-	-	-	36	0.2	92	0.51
	500	-	-	-	-	-	-	34	0.37	89	0.98
	750	-	-	-	-	-	-	32	0.53	86	1.42
	1000	-	-	-	-	-	-	31	0.68	80	1.76
	1500	-	-	-	-	-	-	27	0.89	72	2.38
	2400	-	-	-	-	-	-	25	1.32	65	3.44
6:1	50	-	-	-	-	-	-	33	0.03	66	0.06
	250	-	-	-	-	-	-	30	0.14	71	0.33
	500	-	-	-	-	-	-	29	0.27	69	0.63
	750	-	-	-	-	-	-	29	0.4	68	0.94
	1000	-	-	-	-	-	-	29	0.53	66	1.22
	1500	-	-	-	-	-	-	27	0.74	64	1.75
	2400	-	-	-	-	-	-	25	1.09	57	2.53
3000	-	-	-	-	-	-	23	1.25	54	2.95	
Standard Backlash	arcmin	All Ratios	<15	<15	<20	<20	<20	<20	<20	<20	<20
Allowable Radial Loading*	N	Models B0, C0, D0, G0, H0, J0	Contact GAM	Contact GAM	750	1250	1900				
Allowable Axial Loading	N	Models E0, E0/HSD, K0, KO/HSD	Contact GAM	Contact GAM	375	625	950				
Allowable Radial Loading*	N	Models E0, E0/HSD, K0, KO/HSD	Contact GAM	Contact GAM	Contact GAM	1250	2100				
Allowable Axial Loading	N	Models AO, MO, FO, or input shafts	Contact GAM	Contact GAM	Contact GAM	625	1050				
Allowable Radial Loading*	N	Models AO, MO, FO, or input shafts	Contact GAM	Contact GAM	450	700	1150				
Allowable Axial Loading	N	Models AO, MO, FO, or input shafts	Contact GAM	Contact GAM	225	350	575				
Efficiency at Load			94-98%								
Service Life / Housing Material			10,000 hours / Aluminum			15,000 hours / Cast Iron					
			Synthetic Oil			Synthetic Oil					



Toll Free \*Load applied at the center of shaft @ 100RPM

Toll Free Fax (877) SERV099

67 www.electromate.com

sales@electromate.com

		V-Series											
		140		160		200		230		260		350	
Model		1, 1.5, 2, 3, 4, 5, 6:1											
Size													
Ratios Available													
Ratio	Input Speed (RPM)	Output Torque (Nm)	Power (kW)	Output Torque (Nm)	Power (kW)	Output Torque (Nm)	Power (kW)	Output Torque (Nm)	Power (kW)	Output Torque (Nm)	Power (kW)	Output Torque (Nm)	Power (kW)
1:1	50	220	1.21	380	2.09	750	4.13	1270	7	1750	9.64	4440	24.47
	250	215	5.92	350	9.64	710	19.56	970	26.73	1540	42.44	3440	94.52
	500	208	11.46	330	18.19	620	34.17	820	45.19	1320	72.75	2820	155.41
	750	196	16.2	310	25.63	555	45.88	735	60.76	1170	96.72	2370	195.92
	1000	184	20.28	290	31.96	510	56.21	650	71.65	1050	115.73	1910	210.53
	1500	162	26.78	260	42.99	450	74.4	530	87.63	950	157.07	1620	267.84
	2400	140	37.03	218	57.67	-	-	-	-	-	-	-	-
3000	120	39.68	-	-	-	-	-	-	-	-	-	-	-
1.5:1	50	210	0.76	355	1.29	750	2.73	1330	4.89	1700	6.18	4500	16.34
	250	204	3.76	330	6.07	690	12.7	1120	20.57	1490	27.43	3650	67.11
	500	200	7.34	315	11.56	615	22.57	920	33.9	1300	47.72	3070	112.63
	750	190	10.47	295	16.26	550	30.31	825	45.47	1170	64.48	2560	141.42
	1000	175	12.87	280	20.59	505	37.13	765	56.21	1050	77.19	2560	188.55
	1500	155	17.08	252	27.78	437	48.17	655	72.2	950	104.71	1870	206.19
	2400	126	22.22	205	36.15	360	63.49	518	91.35	900	158.72	-	-
3000	113	24.91	185	40.78	330	72.75	450	99.2	860	189.58	-	-	
2:1	50	200	0.55	355	0.98	750	2.07	1330	3.66	1650	4.55	4640	12.79
	250	190	2.62	320	4.41	680	9.7	1225	16.88	1460	20.12	3930	54.15
	500	180	4.96	300	8.27	610	16.81	970	26.73	1280	35.27	3430	94.52
	750	166	6.86	280	11.57	540	22.32	890	36.79	1170	48.36	3130	129.37
	1000	152	8.38	270	14.88	500	27.56	820	45.19	1050	57.87	2820	155.41
	1500	138	11.41	245	20.25	425	35.13	715	59.11	950	78.53	2420	200.06
	2400	111	14.68	193	25.53	342	45.24	605	80.02	850	112.43	-	-
3000	100	16.53	170	28.11	310	51.25	530	87.63	810	133.92	-	-	
3:1	50	180	0.34	305	0.57	690	1.29	870	1.63	1360	2.55	4240	7.79
	250	177	1.62	280	2.56	630	5.76	825	7.58	1220	11.16	3730	34.26
	500	174	3.2	260	4.79	600	11.04	765	14.07	1110	20.43	3230	59.34
	750	167	4.6	250	6.89	580	15.98	700	19.29	1050	28.93	2950	81.29
	1000	160	5.87	245	8.99	555	20.37	635	23.33	990	36.34	2620	96.26
	1500	146	8.05	230	12.68	515	28.38	540	29.76	900	49.6	2220	122.35
	2400	130	11.46	202	17.81	445	39.24	450	39.68	821	72.39	1820	160.48
3000	110	12.12	190	20.94	420	46.29	400	44.09	780	85.97	-	-	
4:1	50	170	0.23	280	0.39	580	0.8	980	1.35	1320	1.82	3030	4.17
	250	162	1.12	270	1.86	550	3.79	870	5.99	1250	8.61	2820	19.43
	500	154	2.12	260	3.58	525	7.23	795	10.95	1180	16.26	2520	34.72
	750	148	3.06	250	5.17	510	10.54	735	15.19	1100	22.73	2320	47.95
	1000	136	3.75	240	6.61	485	13.36	675	18.6	1050	28.93	2110	58.14
	1500	120	4.96	220	9.09	455	18.81	600	24.8	900	37.2	1910	78.95
	2400	111	7.34	200	13.23	400	26.45	495	32.74	780	51.58	1720	113.75
3000	103	8.51	180	14.88	350	28.93	440	36.37	700	57.87	-	-	
5:1	50	150	0.17	290	0.32	525	0.58	990	1.09	1330	1.47	3230	3.56
	250	143	0.79	270	1.49	505	2.78	920	5.07	1290	7.11	2920	16.09
	500	136	1.5	250	2.76	470	5.18	830	9.15	1200	13.23	2420	26.67
	750	130	2.15	240	3.97	440	7.27	770	12.73	1100	18.19	2170	35.88
	1000	124	2.73	225	4.96	420	9.26	715	15.76	990	21.82	1920	42.33
	1500	115	3.8	215	7.11	380	12.57	635	21	880	29.1	1710	56.54
	2400	105	5.56	198	10.48	340	17.99	550	29.1	760	40.21	1490	78.83
3000	100	6.61	180	11.9	300	19.84	510	33.73	700	46.29	-	-	
6:1	50	120	0.11	197	0.18	306	0.28	625	0.57	951	0.87	2120	1.95
	250	121	0.56	199	0.92	311	1.44	610	2.82	940	4.35	2020	9.28
	500	119	1.09	187	1.72	304	2.79	590	5.42	878	8.06	1820	16.72
	750	117	1.61	176	2.43	289	3.98	565	7.78	792	10.91	1760	24.25
	1000	112	2.06	164	3.01	258	4.74	540	9.92	702	12.93	1710	31.41
	1500	107	2.95	143	3.95	237	6.54	490	13.5	594	16.36	1510	41.61
	2400	104	4.58	136	5.98	218	9.6	410	18.08	524	23.12	1290	56.88
3000	94	5.18	129	7.09	208	11.45	366	20.17	495	27.27	-	-	
arcmin	All Ratios	<20		<20		<20		<20		<20		<20	
N	Models B0, C0, DO, GO, HO, JO	3000		5000		8000		15000		22000		34200	
N	Models E0, E0/HSD, KO, KO/HSD	1500		2500		4000		7500		11000		17100	
N	Models A0, M0, F0, or input shafts	3000		5300		9000		15500		22000		34200	
N		1500		2650		4500		7750		11000		17100	
N		1700		2850		5000		11250		17500		34200	
N		850		1425		2500		5625		8750		17100	
Efficiency at Load		94-98%											
Service Life / Housing Material		10,000 hours / Aluminum						15,000 hours / Cast Iron					
Lubrication		Synthetic Oil						Synthetic Oil					



# V SERIES & L SERIES

Model	L-Series						V-Series					
	Size	035		045		065		090		120		
		1:1	1,2,3,4:1		1, 1.5, 2, 3:1		1, 1.5, 2, 3, 4, 5, 6:1					
Input Speed	Ratios Avail.	Mass Moment of Inertia (kg cm <sup>2</sup> )	Weight (g)	Mass Moment of Inertia (kg cm <sup>2</sup> )	Weight (g)	Mass Moment of Inertia (kg cm <sup>2</sup> )	Weight (kg)	Mass Moment of Inertia (kg cm <sup>2</sup> )	Weight (kg)	Mass Moment of Inertia (kg cm <sup>2</sup> )	Weight (kg)	
A0	1:1	Contact GAM	230	Contact GAM	510	0.3888	2.3	2.5590	5.1	10.4976	12.6	
	1.5:1	-	-	-	-	0.2406	2.3	1.4822	5.1	4.8409	12.6	
	2:1	-	-	Contact GAM	510	0.1839	2.3	1.1437	5.1	3.6465	12.6	
	3:1	-	-	Contact GAM	510	0.1036	2.3	0.8884	5.1	2.3159	12.6	
	4:1	-	-	Contact GAM	510	-	-	0.3631	5.1	1.2164	12.6	
	5:1	-	-	-	-	-	-	0.3248	5.1	0.7516	12.6	
	6:1	-	-	-	-	-	-	0.3062	5.1	0.6766	12.6	
B0	1:1	Contact GAM	225	Contact GAM	500	0.4231	2.2	3.3543	5.4	15.3022	12.3	
	1.5:1	-	-	-	-	0.3111	2.2	2.1833	5.4	7.4441	12.3	
	2:1	-	-	Contact GAM	500	0.2330	2.2	1.3652	5.4	4.9747	12.3	
	3:1	-	-	Contact GAM	500	0.1001	2.2	1.0465	5.4	3.0123	12.3	
	4:1	-	-	Contact GAM	500	-	-	0.4607	5.4	1.6729	12.3	
	5:1	-	-	-	-	-	-	0.3933	5.4	1.0539	12.3	
	6:1	-	-	-	-	-	-	0.3502	5.4	0.8982	12.3	
C0	1:1	Contact GAM	225	Contact GAM	500	0.4231	2.2	3.3543	5.4	15.3022	12.3	
	1.5:1	-	-	-	-	0.3111	2.2	2.1833	5.4	7.4441	12.3	
	2:1	-	-	Contact GAM	500	0.2330	2.2	1.3652	5.4	4.9747	12.3	
	3:1	-	-	Contact GAM	500	0.1001	2.2	1.0465	5.4	3.0123	12.3	
	4:1	-	-	Contact GAM	500	-	-	0.4607	5.4	1.6729	12.3	
	5:1	-	-	-	-	-	-	0.3933	5.4	1.0539	12.3	
	6:1	-	-	-	-	-	-	0.3502	5.4	0.8982	12.3	
D0	1:1	Contact GAM	260	Contact GAM	530	0.4330	2.3	3.3827	5.5	15.5996	12.5	
	1.5:1	-	-	-	-	0.3155	2.3	2.1959	5.5	7.5762	12.5	
	2:1	-	-	Contact GAM	530	0.2355	2.3	1.3723	5.5	5.0490	12.5	
	3:1	-	-	Contact GAM	530	0.1012	2.3	1.0496	5.5	3.0453	12.5	
	4:1	-	-	Contact GAM	530	-	-	0.4625	5.5	1.6915	12.5	
	5:1	-	-	-	-	-	-	0.3945	5.5	1.0712	12.5	
	6:1	-	-	-	-	-	-	0.3510	5.5	0.9065	12.5	
E0	1:1	Contact GAM	210	Contact GAM	460	0.4754	2.1	3.2507	5	15.1939	12	
	1.5:1	-	-	-	-	0.3634	2.1	2.1372	5	7.3959	12	
	2:1	-	-	Contact GAM	460	0.2853	2.1	1.3393	5	4.9476	12	
	3:1	-	-	Contact GAM	460	0.1524	2.1	1.0350	5	3.0003	12	
	4:1	-	-	Contact GAM	460	-	-	0.4542	5	1.6661	12	
	5:1	-	-	-	-	-	-	0.3892	5	1.0550	12	
	6:1	-	-	-	-	-	-	0.3473	5	0.8952	12	
E0/HSD	1:1	-	-	-	-	0.6012	2.1	3.9213	5.2	16.9812	12.3	
	1.5:1	-	-	-	-	0.4892	2.1	2.4353	5.2	8.1903	12.3	
	2:1	-	-	-	-	0.4111	2.1	1.5069	5.2	5.3944	12.3	
	3:1	-	-	-	-	0.2782	2.1	1.1095	5.2	3.1988	12.3	
	4:1	-	-	-	-	-	-	0.4961	5.2	1.7778	12.3	
	5:1	-	-	-	-	-	-	0.4160	5.2	1.1265	12.3	
	6:1	-	-	-	-	-	-	0.3660	5.2	0.9449	12.3	

Sold & Serviced By:



Toll Free Phone (877) SERV098

Toll Free Fax (877) SERV099

69 www.electromate.com

sales@electromate.com

Model	V-Series												
		140		160		200		230		260		350	
	Size	1, 1.5, 2, 3, 4, 5, 6:1											
Input Speed	Ratios Avail.	Mass Moment of Inertia (kg cm <sup>2</sup> )	Weight (kg)	Mass Moment of Inertia (kg cm <sup>2</sup> )	Weight (kg)	Mass Moment of Inertia (kg cm <sup>2</sup> )	Weight (kg)	Mass Moment of Inertia (kg cm <sup>2</sup> )	Weight (kg)	Mass Moment of Inertia (kg cm <sup>2</sup> )	Weight (kg)	Mass Moment of Inertia (kg cm <sup>2</sup> )	Weight (kg)
A0	1:1	26.2670	19	29.6710	28.5	121.2522	52	Contact GAM	79	814.2000	85	Contact GAM	269
	1.5:1	11.8569	19	19.6374	28.5	57.6950	52	Contact GAM	79	305.9333	85	Contact GAM	269
	2:1	8.6762	19	12.3589	28.5	36.3095	52	Contact GAM	79	194.2750	85	Contact GAM	269
	3:1	6.4356	19	8.9516	28.5	18.8322	52	Contact GAM	79	85.0833	85	Contact GAM	269
	4:1	1.8432	19	6.5358	28.5	14.2651	52	Contact GAM	79	46.7738	85	Contact GAM	269
	5:1		19	2.2733	28.5	6.1470	52	Contact GAM	79	37.2840	85	Contact GAM	269
	6:1	1.3708	19	2.0901	28.5	5.3881	52	Contact GAM	79	31.8083	85	Contact GAM	269
B0	1:1	36.0994	18.5	31.5527	28	174.7000	48	Contact GAM	76	827.4400	85	Contact GAM	280
	1.5:1	18.7513	18.5	32.0243	28	103.5829	48	Contact GAM	76	168.2622	85	Contact GAM	280
	2:1	12.2785	18.5	20.1006	28	71.6215	48	Contact GAM	76	281.3350	85	Contact GAM	280
	3:1	7.9547	18.5	12.0803	28	34.1931	48	Contact GAM	76	117.2211	85	Contact GAM	280
	4:1	2.6978	18.5	8.4198	28	22.7181	48	Contact GAM	76	66.6638	85	Contact GAM	280
	5:1	2.2113	18.5	3.6887	28	12.8770	48	Contact GAM	76	50.0136	85	Contact GAM	280
	6:1	1.8426	18.5	2.9407	28	10.0616	48	Contact GAM	76	40.7039	85	Contact GAM	280
C0	1:1	36.0994	18.5	31.5527	28	174.7000	48	Contact GAM	76	827.4400	85	Contact GAM	280
	1.5:1	18.7513	18.5	32.0243	28	103.5829	48	Contact GAM	76	168.2622	85	Contact GAM	280
	2:1	12.2785	18.5	20.1006	28	71.6215	48	Contact GAM	76	281.3350	85	Contact GAM	280
	3:1	7.9547	18.5	12.0803	28	34.1931	48	Contact GAM	76	117.2211	85	Contact GAM	280
	4:1	2.6978	18.5	8.4198	28	22.7181	48	Contact GAM	76	66.6638	85	Contact GAM	280
	5:1	2.2113	18.5	3.6887	28	12.8770	48	Contact GAM	76	50.0136	85	Contact GAM	280
	6:1	1.8426	18.5	2.9407	28	10.0616	48	Contact GAM	76	40.7039	85	Contact GAM	280
D0	1:1	37.0815	19	32.5820	28.5	177.8173	50	Contact GAM	78	841.8500	88	Contact GAM	287
	1.5:1	19.1878	19	32.4818	28.5	104.9684	50	Contact GAM	78	383.5556	88	Contact GAM	287
	2:1	12.5241	19	20.3579	28.5	72.4008	50	Contact GAM	78	284.9375	88	Contact GAM	287
	3:1	8.0639	19	12.1947	28.5	34.5395	50	Contact GAM	78	52.2667	88	Contact GAM	287
	4:1	2.7592	19	8.4841	28.5	22.9130	50	Contact GAM	78	67.5644	88	Contact GAM	287
	5:1	2.2506	19	3.7299	28.5	13.0016	50	Contact GAM	78	50.5900	88	Contact GAM	287
	6:1	1.8698	19	2.9693	28.5	10.1482	50	Contact GAM	78	41.1042	88	Contact GAM	287
E0	1:1	32.6630	18	34.3851	27	201.3904	48	Contact GAM	71	828.6900	82	Contact GAM	259
	1.5:1	17.2240	18	33.1416	27	109.0267	48	Contact GAM	71	413.2622	82	Contact GAM	259
	2:1	11.4194	18	20.6658	27	76.4341	48	Contact GAM	71	287.8975	82	Contact GAM	259
	3:1	7.5729	18	12.3315	27	35.2209	48	Contact GAM	71	120.1100	82	Contact GAM	259
	4:1	2.4830	18	8.5611	27	23.3588	48	Contact GAM	71	68.2888	82	Contact GAM	259
	5:1	2.0739	18	3.7791	27	13.8070	48	Contact GAM	71	51.0536	82	Contact GAM	259
	6:1	1.7471	18	3.0048	27	10.7075	48	Contact GAM	71	41.4261	82	Contact GAM	259
E0/HSD	1:1	39.0643	18.7	40.6750	27.5	222.4124	49.3	Contact GAM	72	892.3400	84.9	Contact GAM	264
	1.5:1	20.0691	18.7	35.9371	27.5	118.3707	49.3	Contact GAM	72	441.5511	84.9	Contact GAM	264
	2:1	13.0198	18.7	22.2382	27.5	81.6896	49.3	Contact GAM	72	303.8100	84.9	Contact GAM	264
	3:1	8.2842	18.7	13.0304	27.5	37.5567	49.3	Contact GAM	72	127.1800	84.9	Contact GAM	264
	4:1	2.8831	18.7	8.9542	27.5	24.6726	49.3	Contact GAM	72	72.2656	84.9	Contact GAM	264
	5:1	2.3299	18.7	4.0307	27.5	14.6479	49.3	Contact GAM	72	53.5988	84.9	Contact GAM	264
	6:1	1.9249	18.7	3.1795	27.5	11.2914	49.3	Contact GAM	72	43.1936	84.9	Contact GAM	264



Toll Free Phone (877) SERV098  
Toll Free Fax (877) SERV099  
www.electromate.com  
sales@electromate.com



# V SERIES & L SERIES

Model	L-Series						V-Series					
	Size	035		045		065		090		120		
		Ratios Avail.	Mass Moment of Inertia (kg cm <sup>2</sup> )	Weight (g)	Mass Moment of Inertia (kg cm <sup>2</sup> )	Weight (g)	Mass Moment of Inertia (kg cm <sup>2</sup> )	Weight (kg)	Mass Moment of Inertia (kg cm <sup>2</sup> )	Weight (kg)	Mass Moment of Inertia (kg cm <sup>2</sup> )	Weight (kg)
F0	1:1	Contact GAM	290	Contact GAM	700	0.5832	2.7	3.8385	6.3	15.7464	15	
	1.5:1	-	-	-	-	0.3270	2.7	2.0508	6.3	7.1737	15	
	2:1	-	-	Contact GAM	700	0.2325	2.7	1.4636	6.3	4.9587	15	
	3:1	-	-	Contact GAM	700	0.1252	2.7	1.0305	6.3	2.8991	15	
	4:1	-	-	Contact GAM	700	-	-	0.4430	6.3	1.5444	15	
	5:1	-	-	-	-	-	-	0.3760	6.3	0.9615	15	
	6:1	-	-	-	-	-	-	0.3418	6.3	0.8224	15	
G0	1:1	Contact GAM	285	Contact GAM	660	0.6175	2.6	4.6338	6.9	20.5510	14.7	
	1.5:1	-	-	-	-	0.4653	2.6	3.0968	6.9	9.9522	14.7	
	2:1	-	-	Contact GAM	660	0.3683	2.6	2.1890	6.9	7.3090	14.7	
	3:1	-	-	Contact GAM	660	0.1821	2.6	1.7927	6.9	4.7450	14.7	
	4:1	-	-	Contact GAM	660	-	-	0.7438	6.9	2.5612	14.7	
	5:1	-	-	-	-	-	-	0.6669	6.9	1.6009	14.7	
	6:1	-	-	-	-	-	-	0.6206	6.9	1.4290	14.7	
H0	1:1	Contact GAM	285	Contact GAM	660	0.6175	2.6	4.6338	6.9	20.5510	14.7	
	1.5:1	-	-	-	-	0.4653	2.6	3.0968	6.9	9.9522	14.7	
	2:1	-	-	Contact GAM	660	0.3683	2.6	2.1890	6.9	7.3090	14.7	
	3:1	-	-	Contact GAM	660	0.1821	2.6	1.7927	6.9	4.7450	14.7	
	4:1	-	-	Contact GAM	660	-	-	0.7438	6.9	2.5612	14.7	
	5:1	-	-	-	-	-	-	0.6669	6.9	1.6009	14.7	
	6:1	-	-	-	-	-	-	0.6206	6.9	1.4290	14.7	
J0	1:1	Contact GAM	290	Contact GAM	690	0.6274	2.7	4.6622	7	20.8484	14.9	
	1.5:1	-	-	-	-	0.4697	2.7	3.1094	7	10.0843	14.9	
	2:1	-	-	Contact GAM	690	0.3708	2.7	2.1961	7	7.3833	14.9	
	3:1	-	-	Contact GAM	690	0.1832	2.7	1.7958	7	4.7780	14.9	
	4:1	-	-	Contact GAM	690	-	-	0.7456	7	2.5798	14.9	
	5:1	-	-	-	-	-	-	0.6681	7	1.6128	14.9	
	6:1	-	-	-	-	-	-	0.6217	7	1.4373	14.9	
K0	1:1	Contact GAM	270	Contact GAM	620	0.6698	2.5	4.5302	6.5	20.4427	14.4	
	1.5:1	-	-	-	-	0.5176	2.5	3.0507	6.5	9.9040	14.4	
	2:1	-	-	Contact GAM	620	0.4206	2.5	2.1631	6.5	7.2819	14.4	
	3:1	-	-	Contact GAM	620	0.2344	2.5	1.7812	6.5	4.7330	14.4	
	4:1	-	-	Contact GAM	620	-	-	0.7373	6.5	2.5544	14.4	
	5:1	-	-	-	-	-	-	0.6628	6.5	1.5966	14.4	
	6:1	-	-	-	-	-	-	0.6180	6.5	1.4260	14.4	
K0/HSD	1:1	-	-	-	-	0.7956	2.5	5.2008	6.7	22.2300	14.7	
	1.5:1	-	-	-	-	0.6434	2.5	3.3488	6.7	10.6984	14.7	
	2:1	-	-	-	-	0.5464	2.5	2.3307	6.7	7.7287	14.7	
	3:1	-	-	-	-	0.3602	2.5	1.8557	6.7	4.9315	14.7	
	4:1	-	-	-	-	-	-	0.7792	6.7	2.6661	14.7	
	5:1	-	-	-	-	-	-	0.6896	6.7	1.6681	14.7	
	6:1	-	-	-	-	-	-	0.6367	6.7	1.4757	14.7	
M0	1:1	Contact GAM	290	Contact GAM	700	0.5832	2.7	3.8385	6.3	15.7464	15	
	1.5:1	-	-	-	-	0.3948	2.7	2.3957	6.3	7.3490	15	
	2:1	-	-	Contact GAM	700	0.3192	2.7	1.9675	6.3	5.9808	15	
	3:1	-	-	Contact GAM	700	0.1856	2.7	1.6346	6.3	4.0486	15	
	4:1	-	-	Contact GAM	700	-	-	0.6462	6.3	2.1047	15	
	5:1	-	-	-	-	-	-	0.5984	6.3	1.2932	15	
	6:1	-	-	-	-	-	-	0.5769	6.3	1.2074	15	

Sold & Serviced By:



Toll Free Phone (877) SERV098

Toll Free Fax (877) SERV099

71 www.electromate.com

sales@electromate.com

Model	V-Series													
	140			160			200		230		260		350	
	Size	1, 1.5, 2, 3, 4, 5, 6:1												
Input Speed	Ratios Avail.	Mass Moment of Inertia (kg cm <sup>2</sup> )	Weight (kg)	Mass Moment of Inertia (kg cm <sup>2</sup> )	Weight (kg)	Mass Moment of Inertia (kg cm <sup>2</sup> )	Weight (kg)	Mass Moment of Inertia (kg cm <sup>2</sup> )	Weight (kg)	Mass Moment of Inertia (kg cm <sup>2</sup> )	Weight (kg)	Mass Moment of Inertia (kg cm <sup>2</sup> )	Weight (kg)	
F0	1:1	39.4005	23	44.5065	35	181.8783	60	Contact GAM	97	1221.3000	105	Contact GAM	340	
	1.5:1	17.6940	23	26.2309	35	84.6400	60	Contact GAM	97	486.8667	105	Contact GAM	340	
	2:1	11.9596	23	16.0678	35	51.4661	60	Contact GAM	97	296.0500	105	Contact GAM	340	
	3:1	7.8949	23	10.6000	35	25.5685	60	Contact GAM	97	130.3167	105	Contact GAM	340	
	4:1	2.6641	23	7.3620	35	18.0543	60	Contact GAM	97	72.2175	105	Contact GAM	340	
	5:1	2.0574	23	2.8667	35	8.5721	60	Contact GAM	97	53.5680	105	Contact GAM	340	
	6:1	1.7356	23	2.5022	35	7.0721	60	Contact GAM	97	43.1167	105	Contact GAM	340	
G0	1:1	49.2329	22.7	46.3882	34.5	235.3261	58	Contact GAM	100	1234.5400	109	Contact GAM	372	
	1.5:1	24.7711	22.7	45.0681	34.5	134.3330	58	Contact GAM	100	293.2622	109	Contact GAM	372	
	2:1	17.6713	22.7	28.2506	34.5	92.7745	58	Contact GAM	100	373.8350	109	Contact GAM	372	
	3:1	12.9310	22.7	19.3835	34.5	46.2891	58	Contact GAM	100	157.0711	109	Contact GAM	372	
	4:1	3.7202	22.7	13.9274	34.5	33.1941	58	Contact GAM	100	87.9938	109	Contact GAM	372	
	5:1	3.2180	22.7	5.3686	34.5	16.5990	58	Contact GAM	100	71.0136	109	Contact GAM	372	
	6:1	2.8486	22.7	4.6187	34.5	13.7656	58	Contact GAM	100	61.2039	109	Contact GAM	372	
H0	1:1	49.2329	22.7	46.3882	34.5	235.3261	58	Contact GAM	100	1234.5400	109	Contact GAM	372	
	1.5:1	24.7711	22.7	45.0681	34.5	134.3330	58	Contact GAM	100	293.2622	109	Contact GAM	372	
	2:1	17.6713	22.7	28.2506	34.5	92.7745	58	Contact GAM	100	373.8350	109	Contact GAM	372	
	3:1	12.9310	22.7	19.3835	34.5	46.2891	58	Contact GAM	100	157.0711	109	Contact GAM	372	
	4:1	3.7202	22.7	13.9274	34.5	33.1941	58	Contact GAM	100	87.9938	109	Contact GAM	372	
	5:1	3.2180	22.7	5.3686	34.5	16.5990	58	Contact GAM	100	71.0136	109	Contact GAM	372	
	6:1	2.8486	22.7	4.6187	34.5	13.7656	58	Contact GAM	100	61.2039	109	Contact GAM	372	
J0	1:1	50.2150	23.2	47.4175	35	238.4434	60	Contact GAM	102	1248.9500	112	Contact GAM	379	
	1.5:1	25.2076	23.2	45.5256	35	135.7185	60	Contact GAM	102	508.5556	112	Contact GAM	379	
	2:1	17.9169	23.2	29.0079	35	93.5538	60	Contact GAM	102	377.4375	112	Contact GAM	379	
	3:1	13.0402	23.2	19.4979	35	46.6355	60	Contact GAM	102	92.1167	112	Contact GAM	379	
	4:1	3.7816	23.2	13.9917	35	33.3890	60	Contact GAM	102	88.8944	112	Contact GAM	379	
	5:1	3.2573	23.2	5.4098	35	16.7236	60	Contact GAM	102	71.5900	112	Contact GAM	379	
	6:1	2.8758	23.2	4.6473	35	13.8522	60	Contact GAM	102	61.6042	112	Contact GAM	379	
K0	1:1	45.7965	22.2	49.2206	34	262.0165	58	Contact GAM	95	1235.7900	106	Contact GAM	351	
	1.5:1	23.2438	22.2	46.1854	34	139.7777	58	Contact GAM	95	538.2622	106	Contact GAM	351	
	2:1	16.8122	22.2	29.3158	34	97.5871	58	Contact GAM	95	380.3975	106	Contact GAM	351	
	3:1	12.5492	22.2	19.6347	34	47.3169	58	Contact GAM	95	159.9600	106	Contact GAM	351	
	4:1	3.5054	22.2	14.0687	34	33.8348	58	Contact GAM	95	89.6188	106	Contact GAM	351	
	5:1	3.0806	22.2	5.4590	34	17.5290	58	Contact GAM	95	72.0536	106	Contact GAM	351	
	6:1	2.7531	22.2	4.6828	34	14.4115	58	Contact GAM	95	61.9261	106	Contact GAM	351	
K0/HSD	1:1	52.1978	22.9	55.5105	34.5	283.0385	59.3	Contact GAM	96	1299.4400	108.9	Contact GAM	356	
	1.5:1	26.0089	22.9	48.9809	34.5	149.1208	59.3	Contact GAM	96	566.5511	108.9	Contact GAM	356	
	2:1	18.4126	22.9	30.8882	34.5	102.8426	59.3	Contact GAM	96	396.3100	108.9	Contact GAM	356	
	3:1	13.2605	22.9	20.3336	34.5	49.6527	59.3	Contact GAM	96	167.0300	108.9	Contact GAM	356	
	4:1	3.9055	22.9	14.4618	34.5	35.1486	59.3	Contact GAM	96	93.5956	108.9	Contact GAM	356	
	5:1	3.3366	22.9	5.7106	34.5	18.3699	59.3	Contact GAM	96	74.5988	108.9	Contact GAM	356	
	6:1	2.9309	22.9	4.8575	34.5	14.9954	59.3	Contact GAM	96	63.6936	108.9	Contact GAM	356	
M0	1:1	39.4005	23	44.5065	35	181.8783	60	Contact GAM	97	1221.3000	105	Contact GAM	340	
	1.5:1	17.8767	23	32.6812	35	88.4451	60	Contact GAM	97	430.9333	105	Contact GAM	340	
	2:1	14.0690	23	21.0089	35	57.4625	60	Contact GAM	97	286.7750	105	Contact GAM	340	
	3:1	11.4119	23	16.2548	35	30.9282	60	Contact GAM	97	124.9333	105	Contact GAM	340	
	4:1	2.8656	23	11.9424	35	24.7411	60	Contact GAM	97	68.1038	105	Contact GAM	340	
	5:1	2.5387	23	3.9532	35	9.8690	60	Contact GAM	97	58.2840	105	Contact GAM	340	
	6:1	2.3768	23	3.7681	35	9.0921	60	Contact GAM	97	52.3083	105	Contact GAM	340	

Sold & Serviced By:



Toll Free Phone (877) SERV098

Toll Free Fax (877) SERV099

www.electromate.com

sales@electromate.com



# ▶ HIGH PERFORMANCE: VC SERIES

LL size 35 and 45		035	045	065	090	120	140	160	200	
SS = 30% per hour with ambient temperature of -10 to +30 degrees C										
Ratios Available		1:1	1,2,3,4:1	1, 1.5, 2, 3:1	1, 1.5, 2, 3, 4, 5, 6:1					
Nominal Output Torque (T <sub>2n</sub> )	Nm (lb-in)	1:1	4.5 (40)	9 (80)	8 (71)	25 (221)	50 (443)	120 (1062)	180 (1593)	350 (3098)
		1.5:1	-	-	10 (89)	25 (221)	61 (540)	113 (1000)	185 (1637)	330 (2921)
		2:1	-	7 (62)	10 (89)	25 (221)	65 (575)	110 (974)	185 (1637)	320 (2832)
		3:1	-	5.5 (49)	8 (71)	23 (204)	58 (513)	110 (974)	190 (1682)	420 (3717)
		4:1	-	4.5 (40)	-	23 (204)	60 (531)	105 (929)	180 (1593)	350 (3098)
		5:1	-	-	-	23 (204)	60 (531)	100 (885)	180 (1593)	300 (2655)
		6:1	-	-	-	23 (204)	54 (478)	95 (841)	130 (1151)	210 (1859)
Max Acceleration Output Torque (T <sub>2B</sub> )	Nm (lb-in)	1:1	5.5 (49)	11 (97)	15 (133)	40 (354)	70 (620)	180 (1593)	350 (3098)	700 (6196)
		1.5:1	-	-	17 (150)	37 (327)	105 (929)	200 (1770)	330 (2921)	690 (6107)
		2:1	-	8.5 (75)	17 (150)	36 (319)	98 (867)	190 (1682)	320 (2832)	600 (5311)
		3:1	-	6.5 (58)	15 (133)	36 (319)	95 (841)	177 (1567)	280 (2478)	630 (5576)
		4:1	-	5.5 (49)	-	36 (319)	87 (770)	162 (1434)	270 (2390)	550 (4868)
		5:1	-	-	-	36 (319)	92 (814)	143 (1266)	270 (2390)	505 (4470)
		6:1	-	-	-	31 (274)	71 (628)	122 (1080)	200 (1947)	315 (2788)
Emergency Output Torque (T <sub>2NOT</sub> )	Nm (lb-in)	1:1	8 (71)	16 (142)	23 (204)	50 (443)	150 (1328)	260 (2301)	480 (4248)	980 (8674)
		1.5:1	-	-	25 (221)	50 (443)	140 (1239)	280 (2478)	500 (4426)	850 (7523)
		2:1	-	12.5 (111)	25 (221)	60 (531)	140 (1239)	280 (2478)	550 (4868)	800 (7081)
		3:1	-	10 (89)	20 (177)	60 (531)	140 (1239)	260 (2301)	400 (3540)	850 (7523)
		4:1	-	8 (71)	-	60 (531)	140 (1239)	260 (2301)	400 (3540)	800 (7081)
		5:1	-	-	-	50 (443)	120 (1062)	220 (1947)	380 (3363)	800 (7081)
		6:1	-	-	-	45 (398)	110 (974)	200 (1947)	350 (3098)	625 (5532)
Vent Filter may be required (n <sub>v</sub> )	RPM	all ratios	-	-	-	>2200	>1700	>1400	>1200	>900
			-	-	-	if housing temperature > 50 degrees C (also depends on duty cycle, ambient temperature, and mounting orientation)				
Max Input Speed (n <sub>1max</sub> )	RPM	1:1	3000	3000	4400	3200	2400	2100	1800	1500
		1.5:1	-	-	6000	4800	3600	3000	2500	2250
		2:1	-	3000	6000	6000	4800	4200	3200	3000
		3:1	-	3000	6000	6000	6000	5000	4500	4000
		4:1	-	3000	-	6000	6000	6000	5000	4500
		5:1	-	-	-	6000	6000	6000	6000	5000
		6:1	-	-	-	6000	6000	6000	6000	6000
Standard Backlash (j)	arcmin	all ratios	<15	<15	<20	<20	<20	<20	<20	<20
Reduced Backlash (j)	arcmin	1:1 - 2:1	<8	<8	<6	<6	<6	<6	<6	<6
		3:1 - 6:1	-	<8	<10	<10	<10	<10	<10	<10
Allowable Radial Load (F <sub>rad</sub> )	N (lbs)	nominal load @100 rpm output	Contact GAM		750 (169)	1250 (281)	2000 (450)	3000 (675)	5300 (1193)	8000 (1800)
Allowable Axial Load (F <sub>axial</sub> )	N (lbs)		Contact GAM		375 (84)	625 (141)	1000 (225)	1500 (338)	2650 (596)	4000 (900)
Weight (m) <sup>3</sup>	kg (lbs)		Contact GAM		2 (4)	4.5 (10)	8 (18)	13 (29)	22 (49)	38.5 (85)
Efficiency at Load		94-98%								
Service Life		10,000 hours / Aluminum				15,000 hours / Cast Iron				
Lubrication		Synthetic Oil				Synthetic Oil				

# ▶ VC SERIES & LL SERIES

LL size 35 and 45		035	045	065	090	120	140	160	200	
	Thermal Limit	0.35 kw	0.60 kw	Housing Temperature <= 90 degrees C						
		Continuous Output Torque (T <sub>n</sub> )								
Ratio	Input Speed	Nm (lb-in)								
1:1	4000 rpm	-	-	3.6 (32)	8 (71)	-	-	-	-	-
	3000 rpm	1.11 (9.8)	1.9 (16.9)	4.8 (42)	11 (97)	18 (159)	-	-	-	-
	2400 rpm	1.39 (12.3)	2.39 (21.1)	6 (51)	14 (124)	23 (204)	37 (327)	56 (496)	-	-
	1500 rpm	2.23 (19.7)	3.8 (33.8)	8 (71)	17 (150)	37 (327)	60 (531)	90 (797)	157 (1390)	-
1.5:1	4000 rpm	-	-	5.4 (48)	12 (106)	21 (186)	34 (301)	-	-	-
	3000 rpm	-	-	7.2 (64)	17 (150)	28 (248)	45 (398)	68 (602)	-	-
	2400 rpm	-	-	9 (80)	21 (186)	35 (310)	56 (496)	85 (752)	147 (1301)	-
	1500 rpm	-	-	10 (89)	25 (221)	56 (496)	90 (797)	136 (1204)	236 (2089)	-
2:1	4000 rpm	-	-	7.2 (64)	17 (150)	28 (248)	45 (398)	-	-	-
	3000 rpm	-	3.81 (33.7)	9.6 (85)	23 (204)	37 (327)	60 (531)	90 (797)	157 (1390)	-
	2400 rpm	-	4.77 (42)	10 (89)	24 (212)	46 (407)	75 (664)	113 (1000)	196 (1735)	-
	1500 rpm	-	7 (62)	10 (89)	27 (239)	73 (646)	120 (1062)	181 (1602)	314 (2779)	-
3:1	4000 rpm	-	-	7.2 (64)	21 (186)	42 (372)	68 (602)	102 (903)	177 (1567)	-
	3000 rpm	-	5.5 (49)	9.6 (85)	23 (204)	56 (496)	90 (797)	136 (1204)	235 (2080)	-
	2400 rpm	-	5.5 (49)	10 (89)	24 (212)	63 (558)	113 (1000)	170 (1505)	294 (2602)	-
	1500 rpm	-	5.5 (49)	10 (89)	27 (239)	74 (655)	130 (1151)	230 (2036)	472 (4178)	-
4:1	4000 rpm	-	-	-	21 (186)	52 (460)	85 (752)	136 (1204)	235 (2080)	-
	3000 rpm	-	4.5 (39.8)	-	23 (204)	60 (531)	103 (912)	180 (1593)	314 (2779)	-
	2400 rpm	-	4.5 (39.8)	-	25 (221)	67 (593)	111 (982)	200 (1770)	393 (3478)	-
	1500 rpm	-	4.5 (39.8)	-	27 (239)	74 (655)	120 (1062)	220 (1947)	455 (4027)	-
5:1	4000 rpm	-	-	-	21 (186)	52 (460)	90 (797)	160 (1416)	275 (2434)	-
	3000 rpm	-	-	-	23 (204)	60 (531)	100 (885)	180 (1593)	300 (2655)	-
	2400 rpm	-	-	-	25 (221)	65 (575)	105 (929)	198 (1752)	340 (3009)	-
	1500 rpm	-	-	-	27 (239)	72 (637)	115 (1018)	215 (1903)	380 (3363)	-
6:1	4000 rpm	-	-	-	21 (186)	45 (398)	85 (752)	115 (1018)	190 (1682)	-
	3000 rpm	-	-	-	23 (204)	54 (478)	95 (841)	130 (1151)	210 (1859)	-
	2400 rpm	-	-	-	25 (221)	59 (522)	102 (903)	137 (1213)	225 (1991)	-
	1500 rpm	-	-	-	27 (239)	64 (566)	108 (956)	145 (1283)	240 (2124)	-

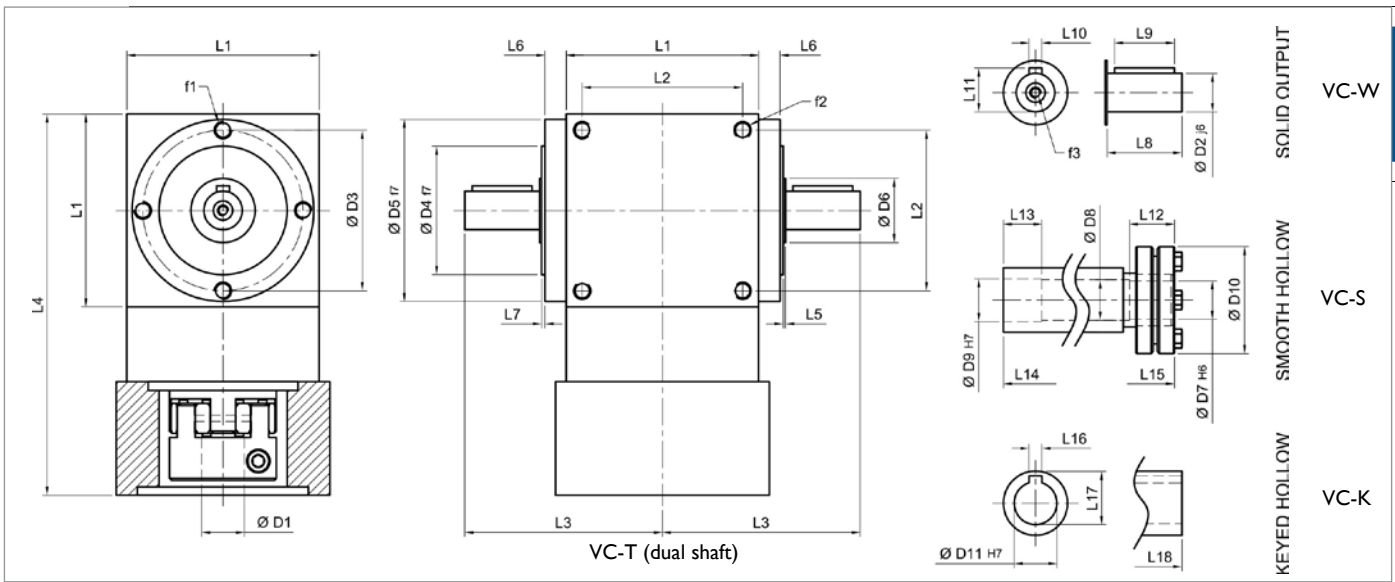

mm (in)		035	045	65	90	120	140	160	200
D1 min	motor shaft diameter	3 (0.118)	3 (0.118)	5 (0.197)	8 (0.315)	13 (0.512)	19 (0.748)	19 (0.748)	24 (0.945)
D1 max		11 (0.433)	11 (0.433)	16 (0.630)	20 (0.787)	28 (1.102)	38.1 (1.500)	38.1 (1.500)	45 (1.772)
D2 j6	output shaft diameter	6 (0.236)	10 (0.393)	12 (0.472)	18 (0.709)	25 (0.984)	32 (1.260)	35 (1.378)	42 (1.654)
	output shaft key size	2 x 2 x 10	3 x 3 x 18	4 x 4 x 20	6 x 6 x 28	8 x 7 x 36	10 x 8 x 45	10 x 8 x 50	12 x 8 x 70
D3	mounting bolt circle 1	29 (1.142)	39 (1.535)	54 (2.126)	75 (2.953)	100 (3.937)	115 (4.528)	135 (5.315)	175 (6.890)
D4 f7	pilot diameter 1	22 (0.866)	32 (1.260)	44 (1.732)	60 (2.362)	80 (3.150)	90 (3.543)	110 (4.331)	120 (4.724)
D5 f7	pilot diameter 2	35 (1.378)	45 (1.772)	64 (2.520)	89 (3.504)	119 (4.685)	135 (5.315)	159 (6.260)	199 (7.835)
D6	shoulder diameter	10 (0.394)	15 (0.591)	17 (0.669)	30 (1.181)	35 (1.378)	50 (1.969)	40 (1.575)	55 (2.165)
D7 H6*	smooth hollow diameter 1	-	-	12 (0.472)	18 (0.709)	25 (0.984)	32 (1.260)	35 (1.378)	42 (1.654)
D8	opened up ID	-	-	13 (0.512)	19 (0.748)	26 (1.024)	33 (1.299)	36 (1.417)	43 (1.693)
D9 H7**	smooth hollow diameter 2	-	-	14 (0.551)	20 (0.787)	27 (1.063)	34 (1.339)	37 (1.457)	44 (1.732)
D10	shrink disc OD	-	-	38 (1.496)	50 (1.969)	60 (2.362)	80 (3.150)	80 (3.150)	100 (3.937)
D11 H7***	keyed hollow diameter	6 (0.236)	10 (0.393)	12 (0.472)	18 (0.709)	25 (0.984)	32 (1.260)	35 (1.378)	42 (1.654)
	hollow shaft key size	2 x 2	3 x 3	4 x 4	6 x 6	8 x 7	10 x 8	10 x 8	12 x 8
L1	housing size	35 (1.378)	45 (1.772)	65 (2.559)	90 (3.543)	120 (4.724)	140 (5.512)	160 (6.299)	200 (7.874)
L2	mounting bolt location 2	25 (0.984)	30 (1.181)	45 (1.772)	70 (2.756)	100 (3.937)	110 (4.331)	120 (4.724)	160 (6.299)
L3	output shaft to centerline	40 (1.575)	57.5 (2.264)	72 (2.835)	95 (3.740)	122 (4.803)	137 (5.394)	160 (6.299)	203 (7.992)
L4****	overall length	Contact GAM		134 (5.276)	185 (7.283)	230 (9.055)	266 (10.47)	295 (11.61)	362 (14.25)
L5	shoulder thickness	0.5 (0.020)	2 (0.079)	2 (0.079)	2 (0.079)	2 (0.079)	2 (0.079)	2 (0.079)	2 (0.079)
L6	output pilot height 2	5.5 (0.217)	8 (0.315)	9.5 (0.374)	10 (0.393)	12 (0.472)	12 (0.472)	15 (0.591)	17 (0.669)
L7	output pilot height 1	1.5 (0.059)	2 (0.079)	2 (0.079)	2 (0.079)	3 (0.118)	3 (0.118)	3 (0.118)	3 (0.118)
L8	output shaft length	15 (0.591)	23 (0.906)	26 (1.024)	35 (1.378)	45 (1.772)	50 (1.969)	60 (2.362)	80 (3.150)
L9	key length	10 (0.393)	18 (0.709)	20 (0.787)	28 (1.102)	36 (1.417)	45 (1.772)	50 (1.969)	70 (2.756)
L10	key width	2 (0.079)	3 (0.118)	4 (0.157)	6 (0.236)	8 (0.315)	10 (0.393)	10 (0.393)	12 (0.472)
L11	shaft height with key	6.8 (0.268)	11.1 (0.437)	13.5 (0.531)	20.5 (0.807)	28 (1.102)	35 (1.378)	38 (1.496)	45 (1.772)
L12	stub shaft length	-	-	17 (0.669)	25 (0.984)	27 (1.063)	32 (1.260)	32 (1.260)	37 (1.457)
L13	diameter 2 length	-	-	15 (0.591)	18 (0.709)	22 (0.866)	25 (0.984)	25 (0.984)	35 (1.378)
L14	hollow shaft to centerline	-	-	46 (1.811)	62 (2.441)	80 (3.150)	90 (3.543)	103 (4.055)	125 (4.921)
L15	shrink disc to centerline	-	-	63 (2.480)	87 (3.425)	107 (4.213)	122 (4.803)	135 (5.315)	162 (6.378)
L16	hollow key width	2 (0.079)	3 (0.118)	4 (0.157)	6 (0.236)	8 (0.315)	10 (0.393)	10 (0.393)	12 (0.472)
L17	hollow height with keyway	7 (0.276)	11.4 (0.449)	13.8 (0.543)	20.8 (0.819)	28.3 (1.114)	35.3 (1.390)	38.3 (1.508)	45.3 (1.783)
L18	hollow shaft to centerline	27 (1.063)	36.5 (1.437)	46 (1.811)	62 (2.441)	80 (3.150)	90 (3.543)	103 (4.055)	125 (4.921)
f1	mounting holes 1	M3 x 5	M4 x 8	M6 x 12	M8 x 14	M10 x 16	M10 x 20	M12 x 24	M12 x 24
f2	mounting holes 2	M3 x 5	M4 x 8	M6 x 9.5	M8 x 10	M10 x 12	M10 x 12	M12 x 15	M12 x 17
B3	mounting holes 3	M3	M3	M4	M6	M10	M12	M12	M16

Sold & Serviced By:

**ELECTROMATE**

Toll Free \*Mating shaft should have h6 tolerance \*\* Mating shaft should have h6 tolerance \*\*\* Mating shaft should have g6 tolerance \*\*\*\* Depending on motor, length may change

Toll Free Fax (877) SERV099

75 www.electromate.com

sales@electromate.com

# ▶ PERFORMANCE: SPIRAL BEVEL SERIES

## Mounting Configuration

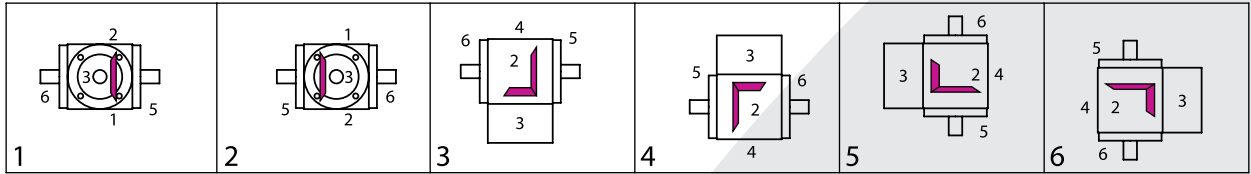

## Breather Location

Shaft Output	 E2	 E1	 E4	 E2	 E4	 E4
Hollow Output	 E4	 E4	 E1 E2	 E1	 E1 E2	 E2 E1
Hollow Output	 E2	 E1	 E4	 E2	 E4	 E4
Hollow Output	 E4	 E4	 E1 E2	 E1	 E1 E2	 E2 E1

Recommended Output Coupling								
VC Series	035	045	065	090	120	140	160	200
bellows	KG-5 or KM-4	KG-10 or KM-12	KM-12 or 20	KLC-25 or 50	KLC-50 or 125	KLC-125 or KM-170	KM-170,270 or 400	KM-270,400 or 550
elastomer	EKC-5	EKM-8 or 15	EKC-5 or 25	EKC-35 or EKM-45	EKC-80 or 110	EKC-110 or EKM-200	EKM-200,300 or 400	EKM-300,500 or 700

## TYPE CODES FOR VC SERIES / LL SERIES

Example: VC - W - 090 - 002 S - [115 - 2AA] - 1-S1-2500-E1-S111

### Gearbox Series

VC - Spiral Bevel Series (size 65-200)  
LL "mini" Spiral Bevel Series (size 35 & 45)

### Gearbox Style

K = Keyed hollow shaft  
W = Single output shaft  
T = Dual output shaft  
S = Smooth hollow output shaft with shrink disc (not available in LL)

### Gearbox Size

Sold & Serviced By: 035, 045, 065, 090



Toll Free Phone (877) SERV098

Toll Free Fax 1 (877) SERV099

www.electromate.com

sales@electromate.com

### Special Options

Assigned by GAM

### Breather Location (if required)

### Maximum Input Speed

Duty Cycle  
S1 = continuous speed  
SS = cyclic

### Mounting Configuration

### Motor Mount Kit

Assigned by GAM

### Backlash

S = Standard Backlash  
R = Reduced Backlash

## TYPE CODES FOR V SERIES / L SERIES

Example: V - 090 - 1:1 - C0 - 750-9.1 - E2/S1

### Gearbox Series

V - Spiral Bevel  
L - "Mini" Spiral Bevel (size 035 and 045)

### Gearbox Size

035, 045, 065, 090, 120, 140, 160, 200, 230, 260, 350

### Ratio

1, 1.5, 2, 3, 4, 5, 6

### Gearbox Model

A0, B0, C0, D0, E0, E0/HSD, F0, G0, H0, J0, K0, K0/HSD, M0

### Duty Cycle

S1 Continuous Speed  
SS Cyclic

### Breather Location

If applicable

### Mounting Configuration

1,2,3,4,5,6

### Mounting Side

9 = Standard  
Tapped holes on housing sides 1, 2, 4 and on output flanges sides 5, 6

### Input Running Speed

0-3000 RPM