

# Harmonic Drive<sup>®</sup>

Sold & Serviced By:



Toll Free Phone (877) SERV098

Toll Free Fax (877) SERV099

[www.electromate.com](http://www.electromate.com)

[sales@electromate.com](mailto:sales@electromate.com)

AC Servo Actuator

## **FHA-C series manual**

---

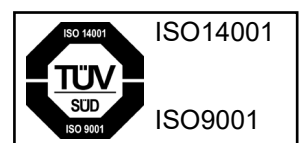
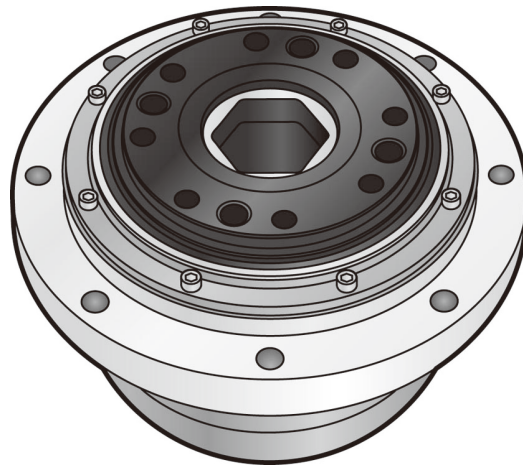

# Introduction



- Thank you very much for purchasing our FHA-C series servo actuator.
- Be sure to use sufficient safety measures when installing and operating the equipment to prevent an accident resulting in a serious physical injury damaged by a malfunction or improper operation.
- Product specifications are subject to change without notice for improvement purposes.
- Keep this manual in a convenient location and refer to it whenever necessary when operating or maintaining the units.
- The end user of the actuator should have a copy of this manual.

# SAFETY GUIDE

To use this actuator safely and correctly, be sure to read SAFETY GUIDE and other parts of this document carefully and fully understand the information provided herein before using the actuator.

## NOTATION

Important safety information you must note is provided herein. Be sure to observe these instructions.

 <b>WARNING</b>	Indicates a potentially hazardous situation, which, if not avoided, could result in death or serious personal injury.
 <b>CAUTION</b>	Indicates a potentially hazardous situation, which, if not avoided, may result in minor or moderate personal injury and/or damage to the equipment.
<b>Caution</b>	Indicates what should be performed or avoided to prevent non-operation or malfunction of the product or negative effects on its performance or function.

## LIMITATION OF APPLICATIONS

The equipment listed in this document may not be used for the applications listed below:

- Space equipment
- Automobile, automotive parts
- Aircraft, aeronautic equipment
- Amusement equipment, sport equipment, game machines
- Nuclear equipment
- Machine or devices acting directly on the human body
- Household apparatus
- Instruments or devices to transport or carry people
- Vacuum equipment
- Apparatus or devices used in special environments

If the above list includes your intending application for our products, please consult us.



**Safety measures are essential to prevent accidents resulting in death, injury or damage of the equipment due to malfunction or faulty operation.**

## SAFETY NOTE

### ITEMS YOU SHOULD NOTE WHEN USING THE ACTUATOR

- **CAUTIONS RELATED TO THE DESIGN**  
**BE SURE TO READ THE MANUAL FOR DESIGNING.**



#### **Always use under followings conditions.**

The actuator is designed to be used indoors. Observe the following conditions:

- Ambient temperature: 0°C to 40°C
- Ambient humidity: 20% to 80%RH (Non-condensation)
- Vibration: Max 24.5 m/s<sup>2</sup>
- No contamination by water, oil
- No corrosive or explosive gas

#### **Follow exactly the instructions in the relating manuals to install the actuator in the equipment.**

- Ensure exact alignment of the actuator center and the center of the corresponding machine by following the manual.
- Failure to observe this caution may lead to vibration, resulting in damage of output elements.

- **CAUTIONS FOR USAGE**  
**BE SURE TO READ THE MANUAL BEFORE OPERATING THE PRODUCT.**



#### **Do not exceed the allowable torque of the actuator.**

- Keep limited torques of the actuator.
- Be aware, that if a load arm attached to the output hits an obstacle by accident, the output shaft may become uncontrollable.

#### **Never connect cables directly to a power supply socket.**

- Each actuator must be operated with a proper driver.
- Failure to observe this caution may lead to injury, fire or damage of the actuator.

#### **Do not apply impacts and shocks**

- The actuator directly connects with the encoder so do not use a hammer during installation.
- Failure to observe this caution could damage the encoder and may cause uncontrollable operation.
- Never apply direct impact to the output shaft.

#### **Avoid handling the actuator by its cables.**

- Failure to observe this caution may damage the wiring, causing uncontrollable or faulty operation.

## ITEMS YOU SHOULD NOTE WHEN USING THE DRIVER

- **CAUTIONS RELATED TO THE DESIGN**  
BE SURE TO READ THE MANUAL FOR DESIGNING.



**CAUTION**

**Always use drivers under followings conditions.**  
The driver generates heat. Use under the following conditions while paying careful attention to the heat radiation.

- Mount in a vertical position keeping sufficient clearance.
- 0°C to 50°C, 95%RH or below (No condensation)
- No vibration or physical shock
- No dust, dirt, corrosive or inflammable gas

**Use sufficient noise suppressing means and safe grounding.**  
Any noise generated on a signal wire will cause vibration or improper motion. Conform to the following conditions.

- Keep signal and power leads separated.
- Keep leads as short as possible.
- Ground actuator and driver at one single point, minimum ground resistance class: D (less than 100 ohms)
- Do not use a power line filter in the motor circuit.

**Pay attention to negative torque by inverse load.**

- Inverse load may cause damages of drivers.
- Please consult our sales office, if you intent to apply products for inverse load.

**Use a fast-response type ground-fault detector designed for PWM inverters.**  
Do not use a time-delay-type ground-fault detector.

- **CAUTIONS FOR USAGE**  
BE SURE TO READ THE MANUAL BEFORE OPERATING THE PRODUCT.



**WARNING**

**Never change wiring while power is active.**  
Make sure of power non-active before servicing the products. Failure to observe this caution may result in electric shock or personal injury.

**Do not touch terminals or inspect products at least 5 minutes after turning OFF power.**

- Otherwise residual electric charges may result in electric shock.
- Make installation of products not easy to touch their inner electric components.

Sold & Serviced By:

 **ELECTROMATE**

Toll Free Phone (877) SERV098

Toll Free Fax (877) SERV099

[www.electromate.com](http://www.electromate.com)

[sales@electromate.com](mailto:sales@electromate.com)



**Do not make a voltage resistance test.**

- Failure to observe this caution may result in damage of the control unit.
- Please consult our sales office, if you intent to use a voltage resistance test.

**Do not operate control units by means of power ON/OFF switching.**

- Start/stop operation should be performed via input signals.
- Failure to observe this caution may result in deterioration of electronic parts.

**DISPOSAL OF AN ACTUATOR AND/OR A DRIVER**



**All products or parts have to be disposed of as industrial waste.**

Since the case or the box of drivers have a material indication, classify parts and dispose them separately.

# Contents

SAFETY GUIDE .....	1
NOTATION .....	1
LIMITATION OF APPLICATIONS.....	1
SAFETY NOTE .....	2
Contents .....	5
Related manual .....	7
Conformance to overseas standards.....	7

## Chapter 1 Outline

---

1-1 Outlines.....	1-1
1-2 Model .....	1-2
1-3 Combination with drivers.....	1-3
1-4 Specifications.....	1-4
1-5 External dimensions.....	1-8
1-6 Mechanical accuracy .....	1-10
1-7 One-way positional accuracy.....	1-11
1-8 Resolution of output shaft .....	1-12
1-9 Rigidity .....	1-13
Moment stiffness .....	1-13
Torsional stiffness.....	1-14
1-10 Rotation direction .....	1-15
1-11 Shock resistance.....	1-16
1-12 Resistance to vibration.....	1-17
1-13 Operable range .....	1-18
1-14 Cable specifications .....	1-23
Motor cable specifications .....	1-23
Encoder cable specifications .....	1-23

## Chapter 2 Selection

---

2-1 Allowable load inertia moment .....	2-1
2-2 Change in load inertia moment .....	2-3
2-3 Verifying and examining load weights .....	2-4
Maximum load weights .....	2-5
Verifying life.....	2-5
Verifying static safety coefficients .....	2-7

2-4	Examining operating status.....	2-8
	Examining actuator rotation speed .....	2-8
	Calculating and examining load inertia moment.....	2-8
	Load torque calculation .....	2-9
	Acceleration time and deceleration time .....	2-10
	Examining effective torque and average rotation speed .....	2-11

### **Chapter 3 Actuator installation**

---

3-1	Receiving Inspection.....	3-1
	Inspection procedure .....	3-1
3-2	Notices on handling .....	3-2
3-3	Location and installation .....	3-3
	Environment of location .....	3-3
	Installation .....	3-4

### **Chapter 4 Options**

---

4-1	Specifications for 100 VAC input power supply (option code: A).....	4-1
4-2	Motor shaft holding brake (option code: B) .....	4-7
	Motor shaft holding brake specifications .....	4-7
	Motor shaft holding brake cable specifications.....	4-8
4-3	With connector (option code: C).....	4-9
4-4	Cable length: 5 m (option code: F5).....	4-10
4-5	Cable taken out from rear face (option code: K) .....	4-11
4-6	Revolution sensor (origin & end limit) (option code: L).....	4-12
	Revolution sensor specifications.....	4-12
	Sensor adjustment method.....	4-13
	Sensor drive range .....	4-14
4-7	Specifications for high accuracy (option code: PR).....	4-15
4-8	Extension cables.....	4-17

### **Appendix**

---

A-1	Unit conversion .....	5-1
A-2	Calculating inertia moment .....	5-3
	Formula of mass and inertia moment .....	5-3
	Inertia moment of cylinder .....	5-5

**Sold & Serviced By:**



**Toll Free Phone (877) SERV098**

**Toll Free Fax (877) SERV099**

**[www.electromate.com](http://www.electromate.com)**

**[sales@electromate.com](mailto:sales@electromate.com)**



# Related manual

The table below lists related manual. Check each item as necessary.

Title	Description
AC Servo Driver HA-800 series manual	The specifications and characteristics of HA-800 series are explained.

# Conformance to overseas standards

The FHA-C series actuators are compliant with the following overseas standards.

<b>UL standards</b>	UL1004-1, UL1004-6 (File No. E243316)
<b>CSA standards</b>	C22.2 No.100
<b>European Low Voltage EC Directives</b>	EN60034-1, EN60034-5

## UL nameplate sticker

According to the UL1004-1, UL1004-6 (File No. E243316) standards, the following specifications are indicated on the FHA-C series actuators.

Nameplate field	Description
(1)	Output [W] at point A on the graph below
(2)	Input power supply [V]
(3)	Allowable continuous current [A]
(4)	Rotational speed at point A on the graph below [r/min]
(5)	Input power supply frequency [Hz]
(6)	Allowable ambient temperature [°C]
(7)	Number of phases

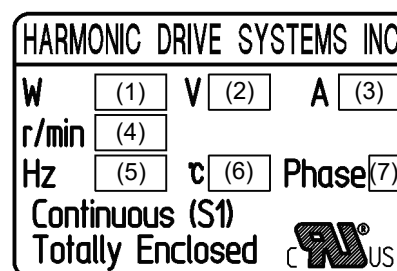

UL nameplate sticker

Example: FHA-40C-100

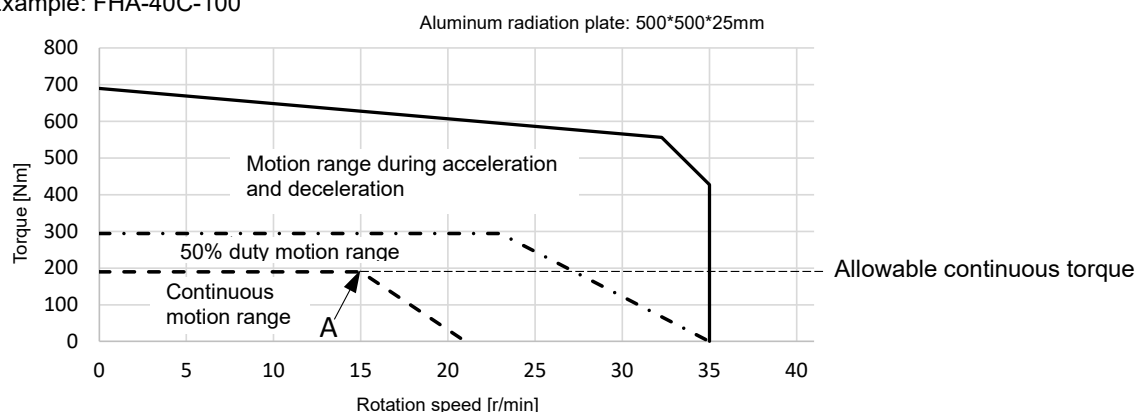

The values displayed on the name plate for each model are shown below.

Item \ Model		FHA-17C									
		Input power supply 200V*					Input power supply 100V*				
		50	80	100	120	160	50	80	100	120	160
(1) Output at point A	W	91	79	75	63	50	91	79	75	63	50
(2) Input power supply	V	200	200	200	200	200	100	100	100	100	100
(3) Allowable continuous current	A	0.93	0.82	0.74	0.63	0.51	1.9	1.7	1.5	1.3	1.0
(4) Speed at point A	rpm	58	37.5	30	25	20	58	37.5	30	25	20
(5) Input power supply frequency	Hz	50/60									
(6) Allowable ambient temperature	°C	40									
(7) Number of phases	—	3									

\*See separate manual for 24VDC

Item \ Model		FHA-25C									
		Input power supply 200V					Input power supply 100V				
		50	80	100	120	160	50	80	100	120	160
(1) Output at point A	W	114	128	157	160	151	111	144	154	151	151
(2) Input power supply	V	200	200	200	200	200	100	100	100	100	100
(3) Allowable continuous current	A	2.1	2.1	2.1	2.0	1.6	4.0	4.0	4.0	4.0	3.2
(4) Speed at point A	rpm	31	23	20	18	17	33	25	21	17	17
(5) Input power supply frequency	Hz	50/60									
(6) Allowable ambient temperature	°C	40									
(7) Number of phases	—	3									

Item \ Model		FHA-32C									
		Input power supply 200V					Input power supply 100V				
		50	80	100	120	160	50	80	100	120	160
(1) Output at point A	W	170	199	218	227	230	114	144	157	162	170
(2) Input power supply	V	200	200	200	200	200	100	100	100	100	100
(3) Allowable continuous current	A	3.1	3.1	3.1	3.1	3.0	4.0	4.0	4.0	4.0	4.0
(4) Speed at point A	rpm	27	20	16	14	11	34	25	20	17	13
(5) Input power supply frequency	Hz	50/60									
(6) Allowable ambient temperature	°C	40									
(7) Number of phases	—	3									

Item \ Model		FHA-40C				
		Input power supply 200V				
		50	80	100	120	160
(1) Output at point A	W	214	273	298	295	314
(2) Input power supply	V	200	200	200	200	200
(3) Allowable continuous current	A	4.0	4.0	4.0	3.9	3.8
(4) Speed at point A	rpm	24	18	15	12.5	10
(5) Input power supply frequency	Hz	50/60				
(6) Allowable ambient temperature	°C	40				
(7) Number of phases	—	3				

Sold & Serviced By:



Toll Free Phone (877) SERV098  
 Toll Free Fax (877) SERV099  
[www.electromate.com](http://www.electromate.com)  
[sales@electromate.com](mailto:sales@electromate.com)



# Chapter 1

## Outline

---

This chapter explains the features, functions and specifications of the actuator.

---

1-1 Outlines .....	1-1
1-2 Model .....	1-2
1-3 Combination with drivers .....	1-3
1-4 Specifications .....	1-4
1-5 External dimensions .....	1-8
1-6 Mechanical accuracy .....	1-10
1-7 One-way positional accuracy .....	1-11
1-8 Resolution of output shaft .....	1-12
1-9 Rigidity .....	1-13
1-10 Rotation direction .....	1-15
1-11 Shock resistance .....	1-16
1-12 Resistance to vibration .....	1-17
1-13 Operating range .....	1-18
1-14 Cable specifications .....	1-23

## 1-1 Outlines

The FHA-C series are AC servo actuators that provide high torque and highly accurate rotary operation. AC Servo Actuator models are comprised of an ultra-thin HarmonicDrive® speed reducer for precision control (size 17 through 40) combined with an ultra-flat AC servo motor.

The HA-800 driver is a servo drive unit for controlling position, speed, and torque, and it controls the FHA-C series actuators' operations with great accuracy and precision.

FHA-C series actuators play an important role in driving various factory automation (FA) equipment, such as robot joints, alignment mechanisms for semi-conductor and LCD devices, ATC of metal-cutting machines, printing machine roller drive, etc.

### ◆ Ultra slim line body

Comprises an ultra-thin HarmonicDrive® speed reducer for precision control with an ultra-flat AC servo motor. The slim body makes it possible to dramatically reduce the size of the machinery being driven.

### ◆ Hollow structure

A through-hole is provided at the center of the actuator, through which wirings, air pipes, and even laser beams can be passed to supply power and give/receive signals to moving parts of machines and devices. This feature can simplify machinery structures.

### ◆ High torque

The actuator houses an ultra-thin HarmonicDrive® speed reducer for precision control to apply much higher output torque on external dimensions compared with methods using direct motor drive.

### ◆ High positional accuracy

Features high positional accuracy with an output shaft resolution of 1600000 pulses/rev (FHA-xxC-160), and uni-directional positional accuracy of 40 seconds (FHA-17C-160) or 30 seconds (FHA-25C/32C/40C-160).

### ◆ High torsional rigidity

Offers improved torsional rigidity (30-100%) over our conventional products. This results in shorter positioning times and reduced vibration when rotating.

### ◆ Incremental encoder

FHA-C series actuators use universally-adopted incremental encoders and reduce encoder wiring. This makes wiring work simple and provides a high degree of reliability.

Sold & Serviced By:



Toll Free Phone (877) SERV098

Toll Free Fax (877) SERV099

[www.electromate.com](http://www.electromate.com)

[sales@electromate.com](mailto:sales@electromate.com)

# 1-2 Ordering Code

Model name for the FHA-C series actuators and how to read the symbols are explained below.

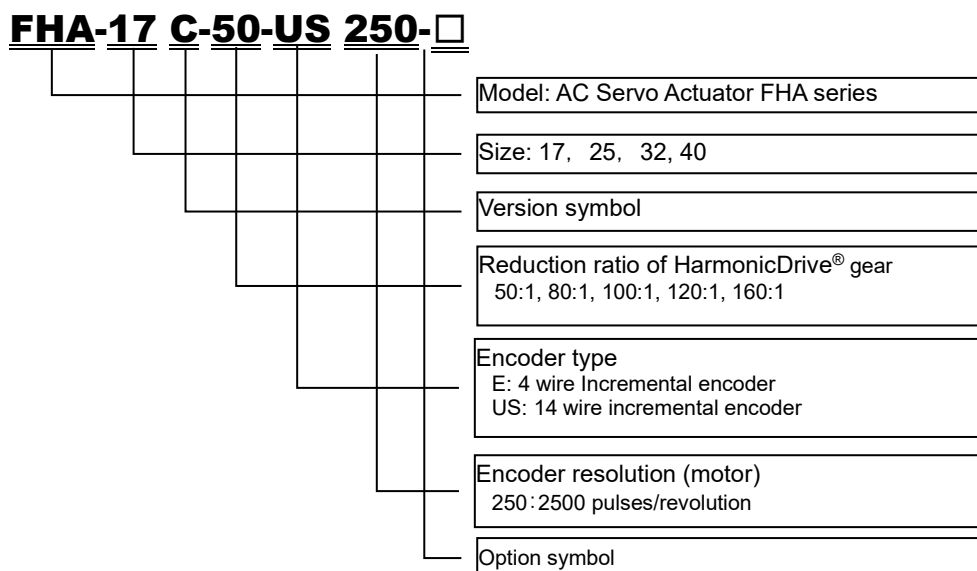

## Option symbol details

Symbol	Detail
A	100VAC power supply (Available for size 17,25, and 32)
B	With Brake
L	Position sensors
C	With connectors for motors (IP-20), for encoders (IP-40)
K	Rear exiting cable
F5	5 meter cables for each motor cable and encoder cable
E	24VDC power supply (Size 17 only)
PR	High Positioning Accuracy

Note: For details on using two or more options together, contact us.

# 1-3 Compatible Drives

Voltage	FHA-17C-xx-US250	FHA-25C-xx-US250	FHA-32C-xx-US250	FHA-40C-xx-US250
<b>200VAC</b>	RTL-230-18 REL-230-18 HA-800*-3C-200	RTL-230-18 REL-230-18 HA-800*-3C-200	RTL-230-18 REL-230-18 HA-800*-6C-200	<i>Ratio 50 &amp; 80:1</i> RTL-230-36 <i>Ratio 50 &amp; 80:1</i> REL-230-36 <i>Ratio &gt; 80:1</i> RTL-230-18 <i>Ratio &gt; 80:1</i> REL-230-18 HA-800*-6C-200
<b>100VAC</b>	RTL-230-18 REL-230-18 HA-800*-3C-100	<i>Ratio 50 &amp; 80:1</i> RTL-230-36 <i>Ratio 50 &amp; 80:1</i> REL-230-36 <i>Ratio &gt; 80:1</i> RTL-230-18 <i>Ratio &gt; 80:1</i> REL-230-18 HA-800*-6C-100	<i>Ratio &lt;120:1</i> RTL-230-36 <i>Ratio &lt;120:1</i> REL-230-36 <i>Ratio &gt;100:1</i> RTL-230-18 <i>Ratio &gt;100:1</i> REL-230-18 HA-800*-6C-100	—
<b>24VDC</b>	DDP-090-36	—	—	—

\* HA-800A: I/O command type, HA-800B: MECHATROLINK-II type, HA-800C: CC-Link type.

For details on combined drives, refer to the drive manual.

# 1-4 Specifications

The specifications of FHA-C series actuators are explained.

Item	Model	FHA-17C				
		50	80	100	120	160
Input power supply	V	AC200				
Combined driver		HA-800□-3C-200				
Max. torque <sup>*1</sup>	N·m	39	51	57	60	64
Allowable continuous torque <sup>*1*2</sup>	N·m	15	20	24	24	24
Max. rotation speed <sup>*1</sup>	rpm	96	60	48	40	30
Torque constant <sup>*1</sup>	N·m/A <sub>rms</sub>	21	33	42	50	67
Max. current <sup>*1</sup>	A <sub>rms</sub>	2.1	1.7	1.6	1.4	1.1
Allowable continuous current <sup>*1*2</sup>	A <sub>rms</sub>	0.93	0.82	0.74	0.63	0.51
EMF constant <sup>*3</sup>	V/(rpm)	2.3	3.7	4.7	5.6	7.5
Phase resistance	Ω(20°C)	7.9				
Phase inductance	mH	6				
Inertia moment (GD <sup>2</sup> /4)	kg·m <sup>2</sup>	0.17	0.43	0.67	0.97	1.7
Inertia moment (J)	kgf·cm·s <sup>2</sup>	1.7	4.4	6.9	10	17
Allowable radial load	kN	2.94				
Allowable axial load	kN	9.8				
Allowable moment load	N·m	188				
Moment stiffness	N·m/rad	220 x 10 <sup>3</sup>				
	kgf·m/arc min	6.5				
One-way positional accuracy	Sec.	60	40	40	40	40
Motor position detector	Pulse/rev.	2500				
Output shaft resolution (multiplied by 4) <sup>*4</sup>	Pulse/rev.	500000	800000	1000000	1200000	1600000
Mass	kg	2.5				
Protection structure		Totally enclosed self-cooled type (IP44)				
Environmental conditions		Operating temperature: 0 to 40°C/Storage temperature: -20 to 60°C Operating humidity/storage humidity: 20 to 80%RH (no condensation) Resistance to vibration: 24.5 m/s <sup>2</sup> (frequency: 10 to 400Hz)/Shock resistance: 294 m/s <sup>2</sup> No dust, no metal powder, no corrosive gas, no inflammable gas, no oil mist To be used indoors, no direct sunlight Altitude: less than 1000 m above sea level				
Motor insulation		Insulation resistance: 100MΩ or more (by DC500V insulation tester) Dielectric strength: AC1500V/1 min Insulation class: F				
Mounting direction		Can be installed in any direction.				

The table shows typical output values of actuators.

\*1: When combined with a HA-800 driver. (Ambient temperature 25°C)

\*2: Value after temperature rise and saturation when the 300 x 300 x 15 [mm] aluminum radiation plate is installed.

\*3: Value of the phase-induced voltage constant multiplied by 3.

\*4: The output shaft resolution is (motor shaft encoder resolution when multiplied by 4) x (reduction ratio).

Sold & Serviced By:



Toll Free Phone (877) SERV098

Toll Free Fax (877) SERV099

[www.electromate.com](http://www.electromate.com)

[sales@electromate.com](mailto:sales@electromate.com)



Item	Model	FHA-25C				
		50	80	100	120	160
Input power supply	V	AC200				
Combined driver		HA-800□-3C-200				
Max. torque <sup>*1</sup>	N·m	150	213	230	247	260
Allowable continuous torque <sup>*1*2</sup>	N·m	35	53	75	85	85
Max. rotation speed <sup>*1</sup>	rpm	90	56	45	37	28
Torque constant <sup>*1</sup>	N·m/A <sub>rms</sub>	22	36	45	54	72
Max. current <sup>*1</sup>	A <sub>rms</sub>	7.3	6.4	5.6	5.0	4.0
Allowable continuous current <sup>*1*2</sup>	A <sub>rms</sub>	2.1	2.1	2.1	2.0	1.6
EMF constant <sup>*3</sup>	V/(rpm)	2.5	4.1	5.1	6.1	8.1
Phase resistance	Ω(20°C)	2.6				
Phase inductance	mH	2.6				
Inertia moment (GD <sup>2</sup> /4)	kg·m <sup>2</sup>	0.81	2.1	3.2	4.7	8.3
Inertia moment (J)	kgf·cm·s <sup>2</sup>	8.3	21	33	48	85
Reduction ratio	-	1:50	1:80	1:100	1:120	1:160
Allowable radial load	kN	4.9				
Allowable axial load	kN	14.7				
Allowable moment load	N·m	370				
Moment stiffness	N·m/rad	490 x 10 <sup>3</sup>				
	kgf·m/arc min	15				
One-way positional accuracy	Sec.	40	30	30	30	30
Motor position detector	Pulse/rev.	2500				
Output shaft resolution (multiplied by 4) <sup>*4</sup>	Pulse/rev.	500000	800000	1000000	1200000	1600000
Mass	Kg	4.0				
Protection structure		Totally enclosed self-cooled type (IP44)				
Environmental conditions		Operating temperature: 0 to 40°C/Storage temperature: -20 to 60°C Operating humidity/storage humidity: 20 to 80%RH (no condensation) Resistance to vibration: 24.5 m/s <sup>2</sup> (frequency: 10 to 400Hz)/Shock resistance: 294 m/s <sup>2</sup> No dust, no metal powder, no corrosive gas, no inflammable gas, no oil mist To be used indoors, no direct sunlight Altitude: less than 1000 m above sea level				
Motor insulation		Insulation resistance: 100MΩ or more (by DC500V insulation tester) Dielectric strength: AC1500V/1 min Insulation class: F				
Mounting direction		Can be installed in any direction.				

The table shows typical output values of actuators.

\*1: When combined with a HA-800 driver. (Ambient temperature 25°C)

\*2: Value after temperature rise and saturation when the 350 x 350 x 18 [mm] aluminum radiation plate is installed.

\*3: Value of the phase-induced voltage constant multiplied by 3.

\*4: The output shaft resolution is (motor shaft encoder resolution when multiplied by 4) x (reduction ratio).

Item	Model	FHA-32C				
		50	80	100	120	160
Input power supply	V	AC200				
Combined driver		HA-800□-6C-200				
Max. torque <sup>*1</sup>	N·m	281	364	398	432	453
Allowable continuous torque <sup>*1*2</sup>	N·m	60	95	130	155	200
Max. rotation speed <sup>*1</sup>	rpm	80	50	40	33	25
Torque constant <sup>*1</sup>	N·m/A <sub>rms</sub>	27	43	54	64	86
Max. current <sup>*1</sup>	A <sub>rms</sub>	11.4	9.2	8.0	7.4	5.9
Allowable continuous current <sup>*1*2</sup>	A <sub>rms</sub>	3.1	3.1	3.1	3.1	3.0
EMF constant <sup>*3</sup>	V/(rpm)	3.0	4.8	5.9	7.2	9.5
Phase resistance	Ω(20°C)	1				
Phase inductance	mH	1.3				
Inertia moment (GD <sup>2</sup> /4)	kg·m <sup>2</sup>	1.8	4.5	7.1	10.2	18.1
Inertia moment (J)	kgf·cm·s <sup>2</sup>	18	46	72	104	185
Allowable radial load	kN	9.5				
Allowable axial load	kN	24.5				
Allowable moment load	N·m	530				
Moment stiffness	N·m/rad	790 x 10 <sup>3</sup>				
	kgf·m/arc min	23				
One-way positional accuracy	Sec.	40	30	30	30	30
Motor position detector	Pulse/rev.	2500				
Output shaft resolution (multiplied by 4) <sup>*4</sup>	Pulse/rev.	500000	800000	1000000	1200000	1600000
Mass	kg	6.5				
Protection structure		Totally enclosed self-cooled type (IP44)				
Environmental conditions		Operating temperature: 0 to 40°C/Storage temperature: -20 to 60°C Operating humidity/storage humidity: 20 to 80%RH (no condensation) Resistance to vibration: 24.5 m/s <sup>2</sup> (frequency: 10 to 400Hz)/Shock resistance: 294 m/s <sup>2</sup> No dust, no metal powder, no corrosive gas, no inflammable gas, no oil mist To be used indoors, no direct sunlight Altitude: less than 1000 m above sea level				
Motor insulation		Insulation resistance: 100MΩ or more (by DC500V insulation tester) Dielectric strength: AC1500V/1 min Insulation class: F				
Mounting direction		Can be installed in any direction.				

The table shows typical output values of actuators.

\*1: When combined with a HA-800 driver. (Ambient temperature 25°C)

\*2: Value after temperature rise and saturation when the 400 x 400 x 20 [mm] aluminum radiation plate is installed.

\*3: Value of the phase-induced voltage constant multiplied by 3.

\*4: The output shaft resolution is (motor shaft encoder resolution when multiplied by 4) x (reduction ratio).

Item	Model	FHA-40C				
		50	80	100	120	160
Input power supply	V	AC200				
Combined driver		HA-800□-6C-200				
Max. torque <sup>*1</sup>	N·m	500	659	690	756	820
Allowable continuous torque <sup>*1*2</sup>	N·m	85	145	190	225	300
Max. rotation speed <sup>*1</sup>	rpm	70	43	35	29	22
Torque constant <sup>*1</sup>	N·m/A <sub>rms</sub>	31	51	64	76	102
Max. current <sup>*1</sup>	A <sub>rms</sub>	17.3	14.0	11.8	10.9	9.0
Allowable continuous current <sup>*1*2</sup>	A <sub>rms</sub>	4.0	4.0	4.0	3.9	3.8
EMF constant <sup>*3</sup>	V/(rpm)	3.6	5.7	7.2	8.6	11.4
Phase resistance	Ω(20°C)	0.73				
Phase inductance	mH	1.5				
Inertia moment (GD <sup>2</sup> /4) <sup>*4</sup>	kg·m <sup>2</sup>	4.9	12.5	19.5	28.1	50
Inertia moment (J)	kgf·cm·s <sup>2</sup>	50	128	200	287	510
Allowable radial load	kN	14.7				
Allowable axial load	kN	39.2				
Allowable moment load	N·m	690				
Moment stiffness	N·m/rad	1400 x 10 <sup>3</sup>				
	kgf·m/arc min	42				
One-way positional accuracy	Sec.	40	30	30	30	30
Motor position detector	Pulse/rev.	2500				
Output shaft resolution (multiplied by 4) <sup>*5</sup>	Pulse/rev.	500000	800000	1000000	1200000	1600000
Mass	kg	12				
Protection structure		Totally enclosed self-cooled type (IP44)				
Environmental conditions		Operating temperature: 0 to 40°C/Storage temperature: -20 to 60°C Operating humidity/storage humidity: 20 to 80%RH (no condensation) Resistance to vibration: 24.5 m/s <sup>2</sup> (frequency: 10 to 400Hz)/Shock resistance: 294 m/s <sup>2</sup> No dust, no metal powder, no corrosive gas, no inflammable gas, no oil mist To be used indoors, no direct sunlight Altitude: less than 1000 m above sea level				
Motor insulation		Insulation resistance: 100MΩ or more (by DC500V insulation tester) Dielectric strength: AC1500V/1 min Insulation class: F				
Mounting direction		Can be installed in any direction.				

The table shows typical output values of actuators.

\*1: When combined with a HA-800 driver. (Ambient temperature 25°C)

\*2: Value after temperature rise and saturation when the 500 x 500 x 25 [mm] aluminum radiation plate is installed.

\*3: Value of the phase-induced voltage constant multiplied by 3.

\*4: For -PR option, see section 4-7.

\*5: The output shaft resolution is (motor shaft encoder resolution when multiplied by 4) x (reduction ratio).

Sold & Serviced By:



Toll Free Phone (877) SERV098

Toll Free Fax (877) SERV099

[www.electromate.com](http://www.electromate.com)

[sales@electromate.com](mailto:sales@electromate.com)



Unit: mm (third angle projection)

● **FHA-32C-xx-US250**

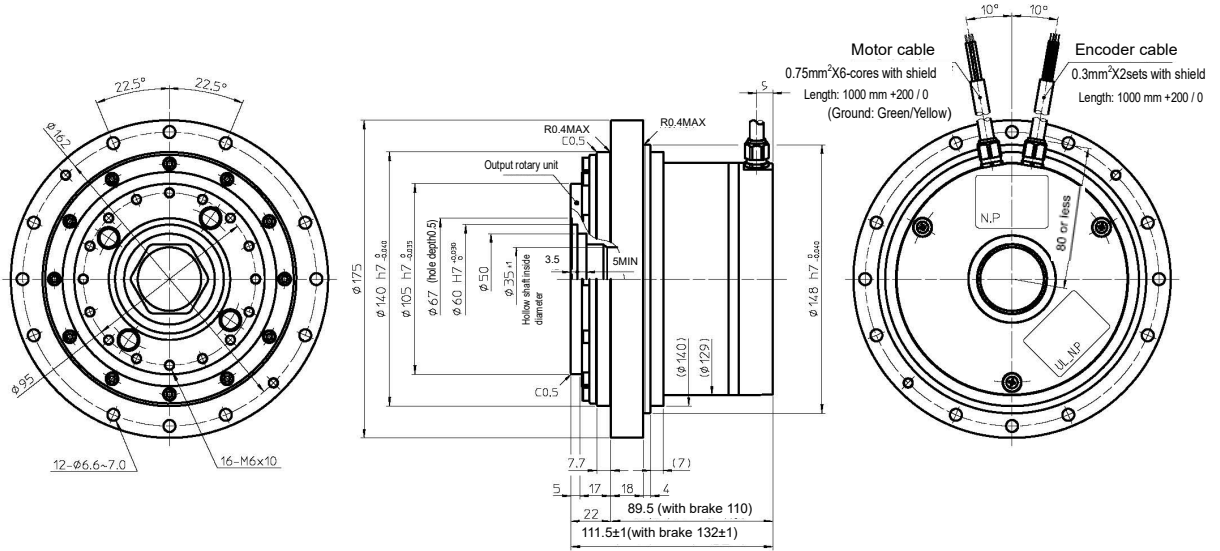

● **FHA-40C-xx-US250**

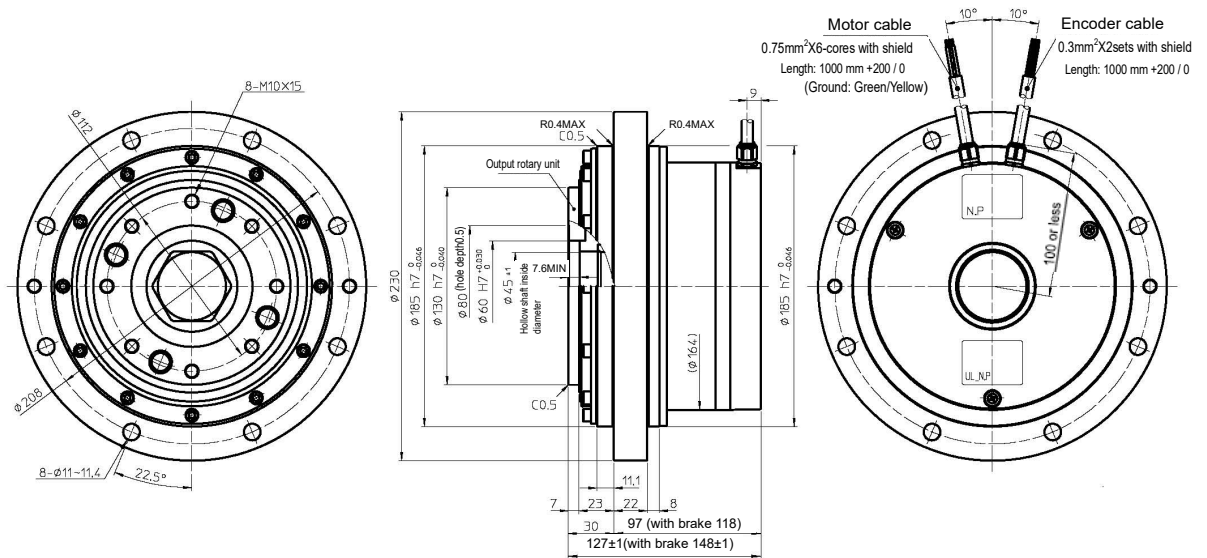

Note: Please check the confirmation drawing or contact us for dimension tolerances not shown.

# 1-6 Mechanical accuracy

1

Outlines

The mechanical accuracies of the output shaft and mounting flange are shown below for FHA-C series actuators:

## Mechanical accuracy

unit: mm

Accuracy items	FHA-17C	FHA-25C	FHA-32C	FHA-40C
1. Axial run-out of output flange	0.010	0.012	0.012	0.014
2. Radial run-out of output flange	0.010	0.012	0.012	0.014
3. Parallelism between the output shaft end mounted surface	0.040	0.050	0.050	0.060
4. Concentricity between the output flange to mounting pilot	0.040	0.050	0.050	0.060

Note: All values are T.I.R. (Total Indicator Reading).

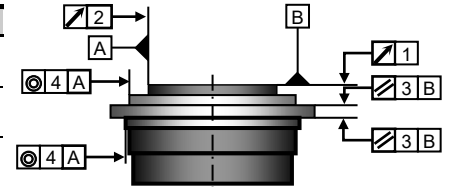

The measuring for the values are as follows:

### 1 Axial run-out of output flange

The indicator on the fixed part measures the axial runout (maximum runout width) of the outermost circumference of output shaft of the output rotary unit per revolution.

### 2 Radial run-out of output flange

The indicator on the fixed part measures the radial runout (maximum runout width) of output shaft of the output rotary unit per revolution.

### 3 Parallelism between the output flange and mounting flange

The indicator on the output rotary unit measures the axial runout (maximum runout width) of the outermost circumference of the mounting surface (both on the output shaft side and opposite side) of the output rotary unit per revolution.

### 4 Concentricity between the output flange to mounting pilot

The indicator on the output rotary unit measures the radial runout (maximum runout width) of the fitting part (both on the output shaft side and opposite side) of the output rotary unit per revolution.

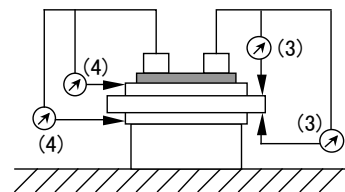
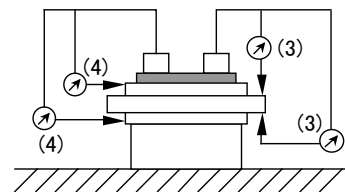
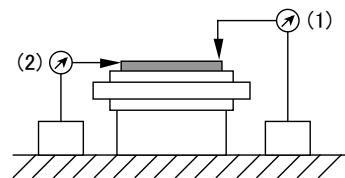

Sold & Serviced By:

 **ELECTROMATE**

Toll Free Phone (877) SERV098

Toll Free Fax (877) SERV099

[www.electromate.com](http://www.electromate.com)

[sales@electromate.com](mailto:sales@electromate.com)

## 1-7 One-way positional accuracy

The one-way positioning accuracy is defined as the maximum positional difference between the commanded position and the actual stop position when a series of positioning moves are performed in the same rotation direction. (Refer to JIS B-6201-1987).

The FHA-C actuator incorporates a Harmonic Drive gear which inherently has high rotational position accuracy. Because of the gearing's high ratio, any rotational error at the input (i.e. motor shaft position error or motor feedback error) is reduced by a factor of the ratio (1/ratio) and typically becomes negligible at the output. Therefore, most of the error is represented by the transmission error of the Harmonic Drive gear itself.

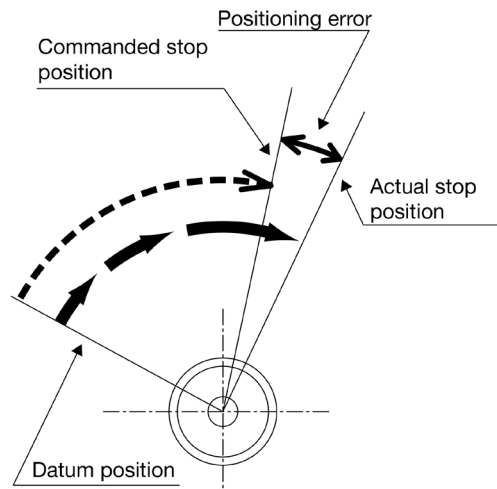

The one-way positional accuracy is shown in the table below: (Unit: sec.)

Model	FHA-17C	FHA-25C	FHA-32C	FHA-40C
<b>Reduction ratio</b>				
<b>50:1</b>	60	40	40	40
<b>80:1 or more</b>	40	30	30	30

## 1-8 Resolution of output shaft

The motors of FHA-C actuators are equipped with an incremental encoder of 2500 resolutions. Because the motor rotation is reduced to 50:1 - 160:1 by the gear component, the resolution of the output flange is 50 to 160 times the encoder revolution. Additionally, the incremental encoder signal is used in quadrature.

All together, this allows for high resolution results as shown in the table below:

Encoder resolution		2500 (10000: when multiplied by 4)				
Reduction ratio		50	80	100	120	160
<b>Resolution of output shaft</b>	<b>Pulse/rev</b>	500000	800000	1000000	1200000	1600000
<b>Resolvable angle per pulse</b>	<b>Sec.</b>	Approx. 2.6	Approx. 1.6	Approx. 1.3	Approx. 1.1	Approx. 0.8



## 1-9 Rigidity

### Moment stiffness

The moment stiffness refers to the torsional stiffness when a load is applied to the output shaft of the actuator, as shown in the figure.

For example, when a load is applied to the end of an arm attached on the output shaft of the actuator, the face of the output shaft of the actuator tilts in proportion to the moment load. The moment stiffness is expressed as the load/gradient angle.

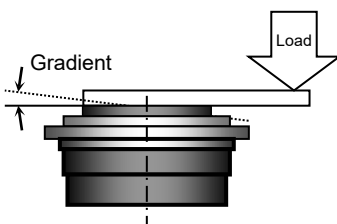

Item	Model	FHA-17C	FHA-25C	FHA-32C	FHA-40C
	Moment stiffness	N·m/rad	220 x 10 <sup>3</sup>	490 x 10 <sup>3</sup>	790 x 10 <sup>3</sup>
kgf·m/rad		22 x 10 <sup>3</sup>	50 x 10 <sup>3</sup>	80 x 10 <sup>3</sup>	140 x 10 <sup>3</sup>
kgf·m/arc-min		6.5	15	23	42

Sold & Serviced By:



Toll Free Phone (877) SERV098

Toll Free Fax (877) SERV099

[www.electromate.com](http://www.electromate.com)

[sales@electromate.com](mailto:sales@electromate.com)

## Torsional stiffness

If a torque is applied to the output shaft of the actuator with the servo locked, the output shaft generates a torsional stress roughly in proportion to the torque.

The upper right figure shows the torsional angle of the output shaft when a torque starting from zero and increased to positive side [+T<sub>0</sub>] and negative side [-T<sub>0</sub>] is applied to the output shaft. This is called [torque vs. torsional angle] diagram, which typically follows a loop 0→A→B→A'→B'→A. The torsional rigidity of the FHA-C series actuator is expressed by the gradient of this [torque vs. torsional angle diagram] representing a spring constant (unit: Nm/rad).

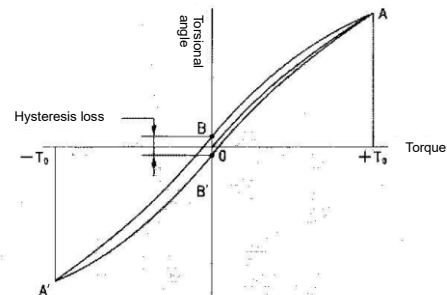

As shown by lower right figure, this [torque vs. torsional angle] diagram is divided into three regions and the spring constants in these regions are expressed by K<sub>1</sub>, K<sub>2</sub>, and K<sub>3</sub>, respectively.

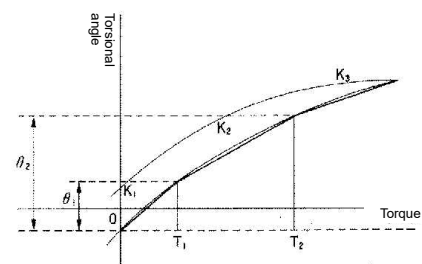

- K<sub>1</sub>: Spring constant for torque region 0 to T<sub>1</sub>
- K<sub>2</sub>: Spring constant for torque region T<sub>1</sub> to T<sub>2</sub>
- K<sub>3</sub>: Spring constant for torque region over T<sub>2</sub>

The torsional angle for each region is expressed as follows: \* φ: Torsional angle

- Range where torque T is T<sub>1</sub> or below:  $\varphi = \frac{T}{K_1}$
- Range where torque T is T<sub>1</sub> to T<sub>2</sub>:  $\varphi = \theta_1 + \frac{T - T_1}{K_2}$
- Range where torque T is T<sub>2</sub> to T<sub>3</sub>:  $\varphi = \theta_2 + \frac{T - T_2}{K_3}$

The table below shows the averages of T<sub>1</sub> to T<sub>3</sub>, K<sub>1</sub> to K<sub>3</sub>, and θ<sub>1</sub> to θ<sub>2</sub> for each actuator.

Model	FHA -17C		FHA -25C		FHA -32C		FHA -40C		
<b>Reduction ratio</b>	50:1	80:1 or more	50:1	80:1 or more	50:1	80:1 or more	50:1	80:1 or more	
T <sub>1</sub>	N·m	7.0	7.0	29	29	54	54	108	108
	kgf·m	0.7	0.7	3.0	3.0	5.5	5.5	11	11
K <sub>1</sub>	x10 <sup>4</sup> N·m/rad	1.1	1.3	4.7	6.1	8.8	11	17	21
	kgf·m/arc min	0.32	0.4	1.4	1.8	2.8	3.2	5.0	6.3
θ <sub>1</sub>	x10 <sup>-4</sup> rad	6.4	5.1	6.2	4.8	6.1	4.9	6.4	5.1
	arc min	2.2	1.8	2.1	1.7	2.1	1.7	2.2	1.8
T <sub>2</sub>	N·m	25	25	108	108	196	196	382	382
	kgf·m	2.5	2.5	11	11	20	20	39	39
K <sub>2</sub>	x10 <sup>4</sup> N·m/rad	1.3	1.7	6.1	7.7	11	14	21	29
	kgf·m/arc min	0.4	0.5	1.8	2.3	3.4	4.2	6.3	8.5
θ <sub>2</sub>	x10 <sup>-4</sup> rad	19.5	15.6	19.2	15	19.1	15.1	19.3	14.7
	arc min	6.7	5.4	6.6	5.1	6.4	5.2	6.6	5.0
K <sub>3</sub>	x10 <sup>4</sup> N·m/rad	2.0	2.5	8.4	11	15	20	30	37
	kgf·m/arc min	0.6	0.75	2.5	3.3	4.5	5.8	9	11

The table below shows reference torque values calculated for different torsional angle.

(Unit: N·m)

Model	FHA -17C		FHA -25C		FHA -32C		FHA -40C	
<b>Reduction ratio</b>	50:1	80:1 or more	50:1	80:1 or more	50:1	80:1 or more	50:1	80:1 or more
<b>2 arc min</b>	6.3	8.1	27	37	51	63	98	129
<b>4 arc min</b>	14	18	62	82	117	148	220	300
<b>6 arc min</b>	22	29	97	136	179	243	340	490

## 1-10 Rotation direction

Forward rotation direction of the actuator is defined as clockwise (CW) rotation as viewed from the load shaft when a FWD rotation command is given to a FHA-C series actuator from a HA-800 driver. This rotation direction can be changed on the HA-800 driver by selecting [SP50: Command polarity setting].

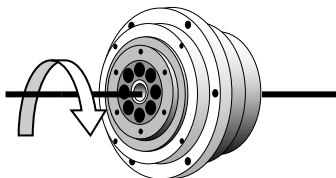

FWD rotation: Clockwise

### Setting of [SP50: Command polarity]

Set value	Forward input	Reverse input	Setting
0	FWD rotation	Reverse	Default
1	Reverse	FWD rotation	

## 1-11 Shock resistance

The shock acceleration with the actuator central shaft mounted horizontally and when impact is applied in the vertical and horizontal directions is as follows:

Shock acceleration:  $294 \text{ m/s}^2$

In our shock resistance test, the actuator is tested three times in each direction. Actuator operation is not guaranteed in applications where impact equivalent to the above value is constantly applied.

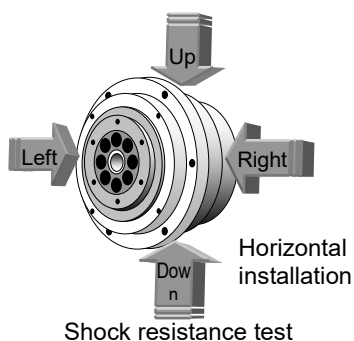

Sold & Serviced By:



Toll Free Phone (877) SERV098

Toll Free Fax (877) SERV099

[www.electromate.com](http://www.electromate.com)

[sales@electromate.com](mailto:sales@electromate.com)

## 1-12 Vibration Resistance

The resistance to vibration of the actuator is as follows, and this value is the same in up/down, left/right and front/rear directions:

Vibration acceleration:  $24.5 \text{ m/s}^2$  (frequency: 10 to 400Hz)

In our test, the actuator is tested for 2 hours in each direction at a vibration frequency sweep period of 10 minutes.

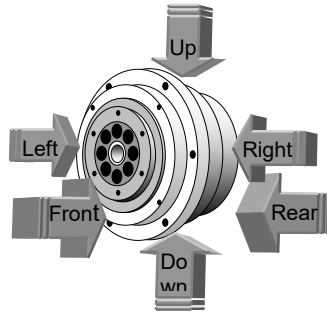

Resistance to vibration test

## 1-13 Operating range

The graph on the next page indicates the operating range when an FHA-C actuator is used with an HA-800 driver. To use FHA-C series actuators at maximum output, refer to [Chapter 2 Selection].

### 1. Continuous motion range

The range allows continuous operation for the actuator.

### 2. 50% duty motion range

This range indicates the torque/speed where 50% duty cycle operation is permitted (the ratio of operating time and delay time is 50:50).

Limit the operation cycle to a period of several minutes, and keep it within a range where the overload alarm of the driver is not issued.

### 3. Motion range during acceleration and deceleration

This range indicates the torque/speed which the actuator can be operated momentarily. The range allows instantaneous operation like acceleration and deceleration, usually.

The continuous and 50% duty motion ranges in each graph are measured when the actuator is mounted to an aluminum heatsink.

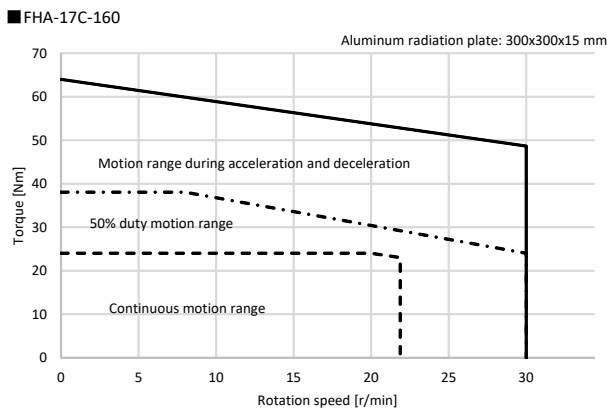
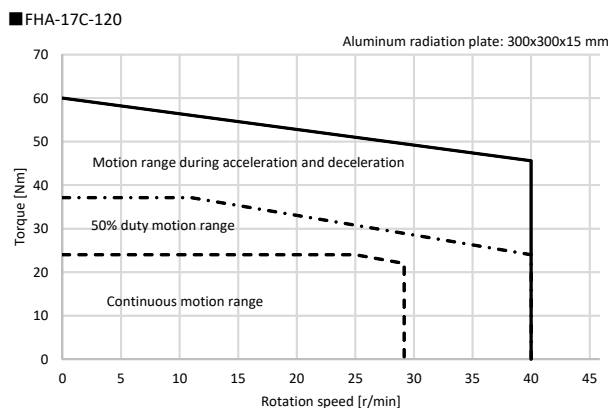
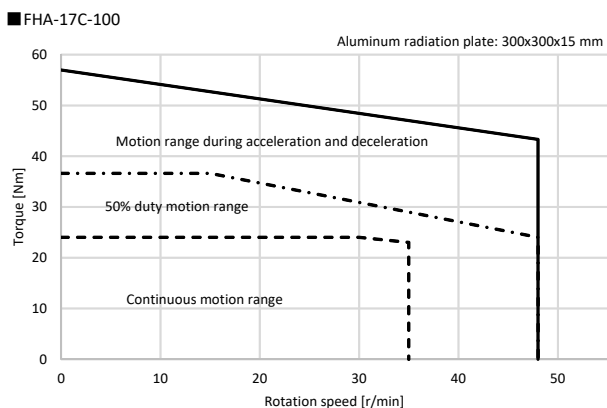
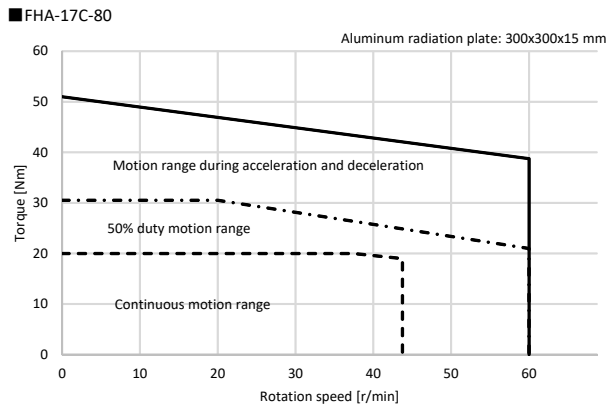
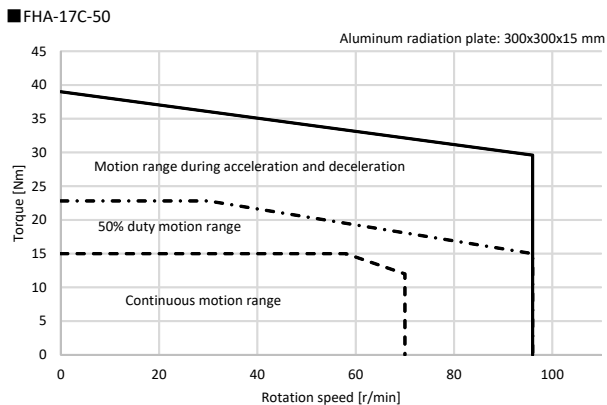

Sold & Serviced By:



Toll Free Phone (877) SERV098

Toll Free Fax (877) SERV099

[www.electromate.com](http://www.electromate.com)

[sales@electromate.com](mailto:sales@electromate.com)

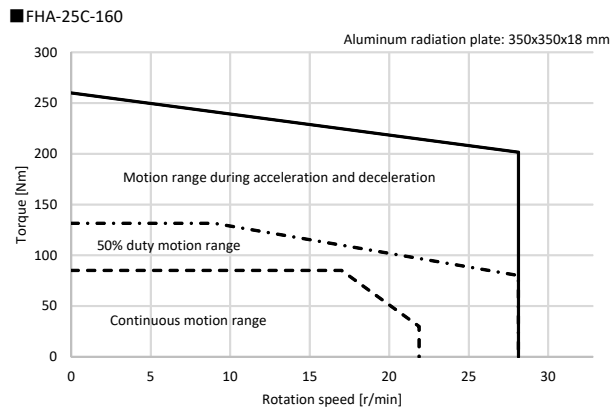
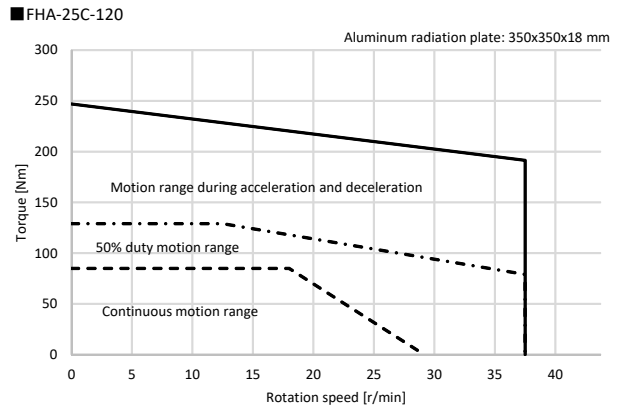
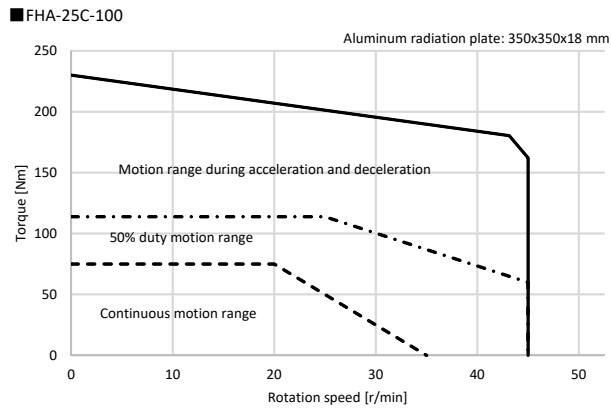
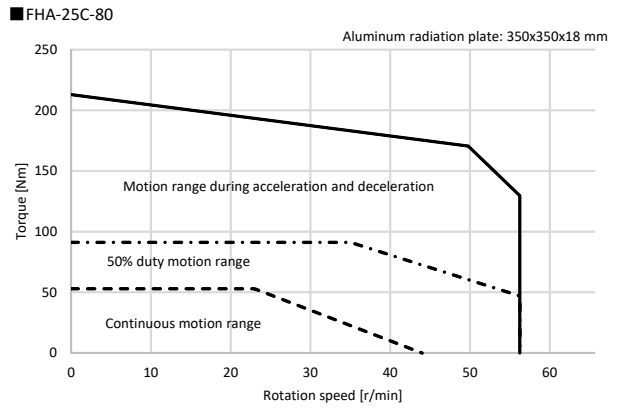
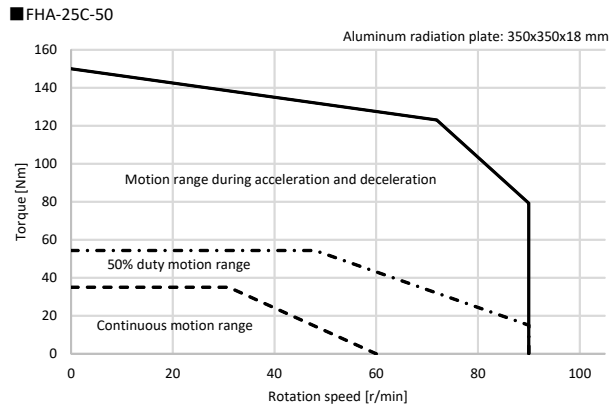



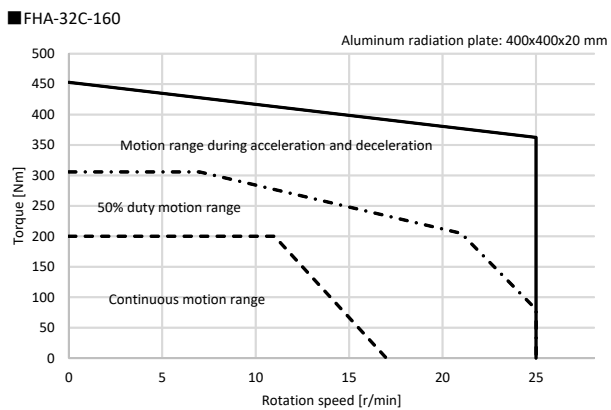
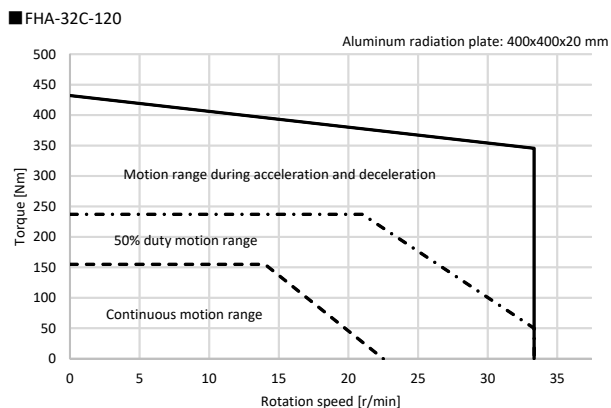
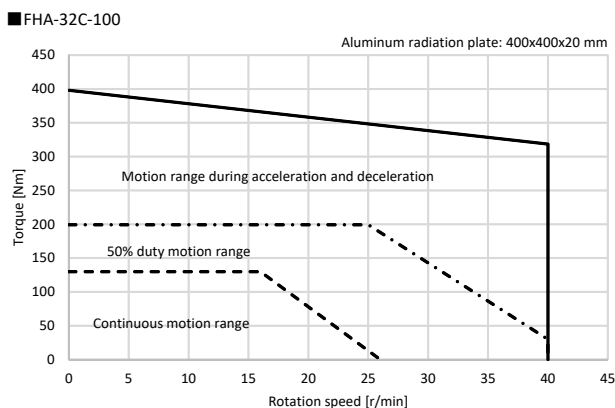
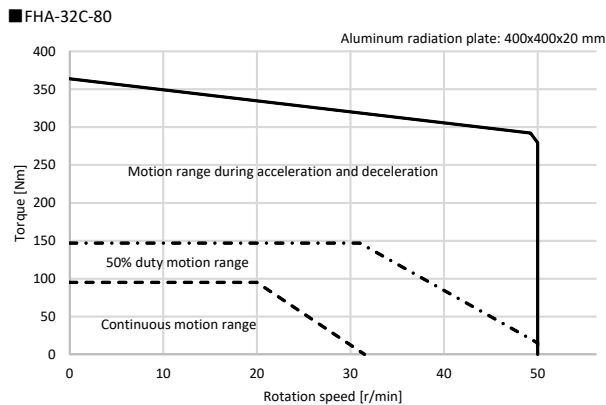
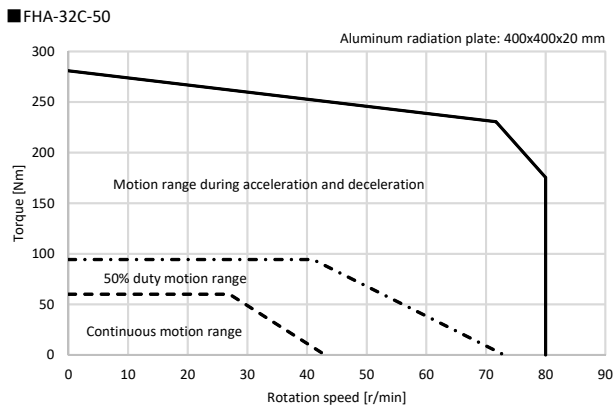

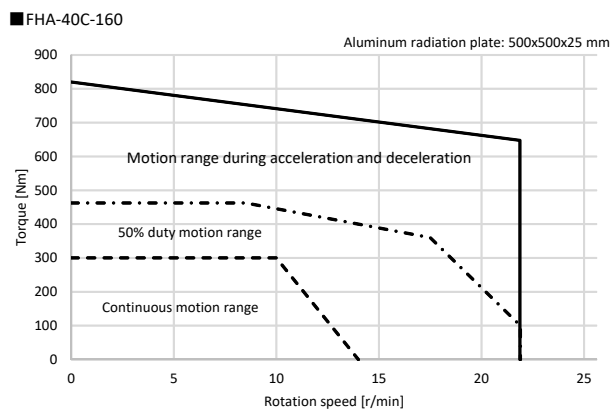
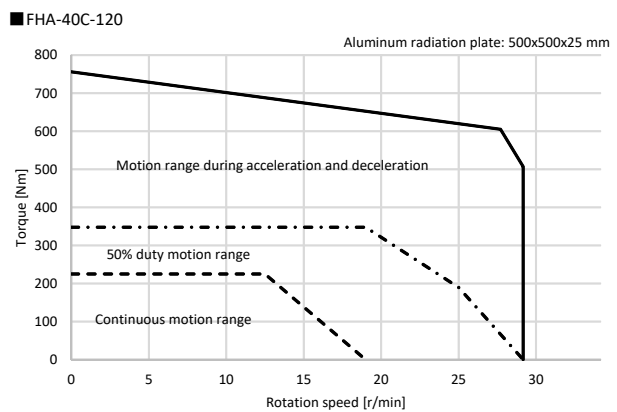
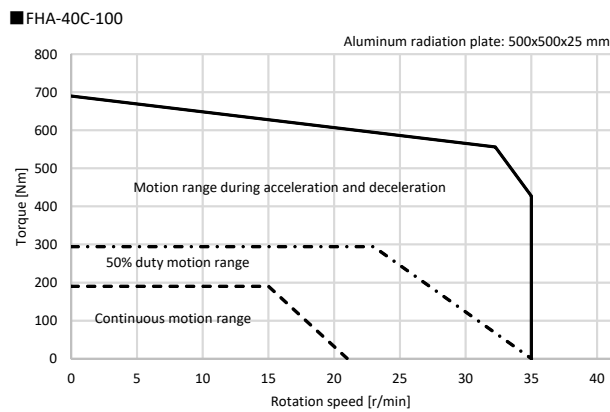
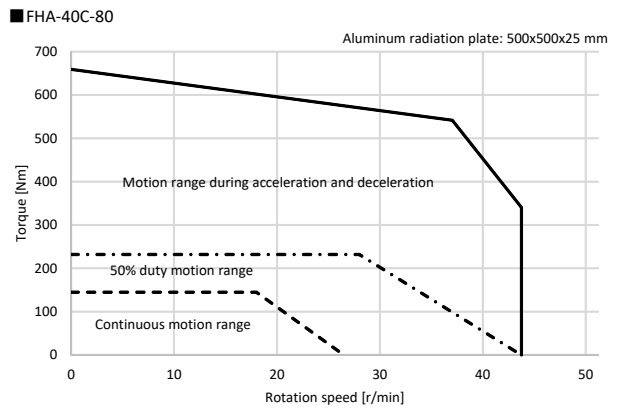
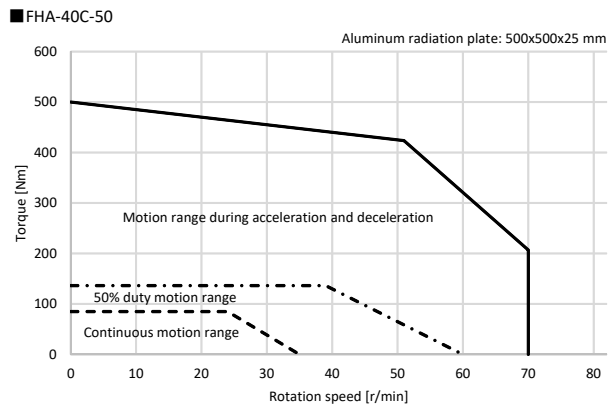

Sold & Serviced By:



Toll Free Phone (877) SERV098

Toll Free Fax (877) SERV099

[www.electromate.com](http://www.electromate.com)

[sales@electromate.com](mailto:sales@electromate.com)

## 1-14 Cable specifications

The following tables show specifications of the motor and encoder cables for the FHA-C series actuators.

### Motor cable specifications

Color	Name	
	Without brake	With brake
Red	Motor phase-U	Motor phase-U
White	Motor phase-V	Motor phase-V
Black	Motor phase-W	Motor phase-W
Green/yellow	PE	PE
Blue	No connection	Brake (24VDC input, no polarity)
Yellow	No connection	Brake (24VDC input, no polarity)
(Shield)	FG	FG

### Encoder cable specifications

Color	Signal name	Remarks
Red	Vcc	Power supply input +5V
Black	GND (Vcc)	Power supply input 0V (GND)
Yellow	SD+	Serial signal differential output (+)
Blue	SD-	Serial signal differential output (-)
Shield	FG	-

5559-16P Pin No.	Color	Signal
1	Green	A
2	Gray	B
3	Yellow	Z
4	Brown	U
5	Blue	V
6	Orange	W
7	Red	+5V
8	—	—
9	White/Green	$\overline{A}$
10	White/Gray	$\overline{B}$
11	White/Yellow	$\overline{Z}$
12	White/Brown	$\overline{U}$
13	White/Blue	$\overline{V}$
14	White/Orange	$\overline{W}$
15	Black	GND
16	Shield	—

# Chapter 2

## Selection

---

This chapter explains how to select a proper FHA-C series actuator.

---

2-1 Allowable load inertia moment .....	2-1
2-2 Change in load inertia moment .....	2-3
2-3 Verifying and examining load weights .....	2-4
2-4 Examining operating status .....	2-8

# 2-1 Allowable load inertia moment

To achieve high accuracy and performance, use the FHA-C series actuator where the allowable value of load inertia moment specified for the applicable model No. is not exceeded.

Note that the allowable values in the table below should be referenced if you wish to shorten the transient vibration period during positioning or operate the actuator at a constant speed in a stable manner. The operation is possible with the allowable value exceeded if the actuator is accelerated/decelerated gradually, commands given from the host to the servo driver are adjusted, or the servo driver's vibration suppression function is used.

Refer to [A-2 Calculating inertia moment] (P5-3) for the calculation of inertia moment.

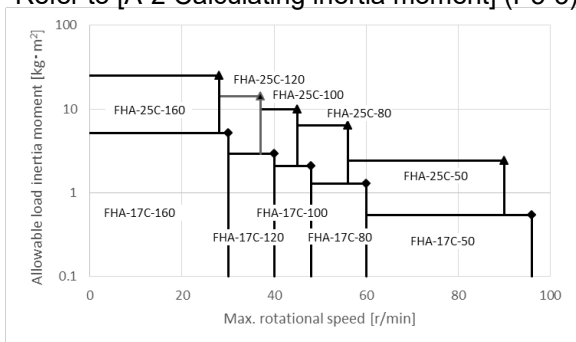

Note: The graph is for actuators with 200 V input power supply.

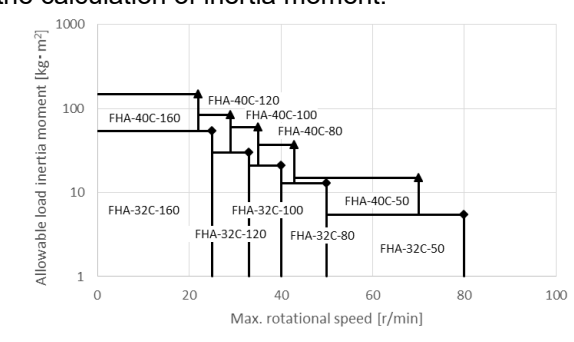

Note: The graph is for actuators with 200 V input power supply.

When temporarily selecting an actuator, make certain that the inertia moment and maximum rotational speed do not exceed the allowable values shown in the table below.

Actuator model			FHA-17C				
			50	80	100	120	160
Reduction ratio		-	50:1	80:1	100:1	120:1	160:1
Max. rotational speed	200V	rpm	96	60	48	40	30
	100V		96	60	48	40	30
Actuator inertia moment		kg·m <sup>2</sup>	0.17	0.43	0.67	0.97	1.7
		kgf·cm·s <sup>2</sup>	1.7	4.4	6.9	10	17
Allowable load inertia moment		kg·m <sup>2</sup>	0.54	1.3	2.1	2.9	5.1
		kgf·cm·s <sup>2</sup>	5.4	13	21	30	52

Actuator model			FHA-25C				
			50	80	100	120	160
Reduction ratio		-	50:1	80:1	100:1	120:1	160:1
Max. rotational speed	200V	rpm	90	56	45	37	28
	100V		90	56	45	37	28
Actuator inertia moment		kg·m <sup>2</sup>	0.81	2.1	3.2	4.7	8.3
		kgf·cm·s <sup>2</sup>	8.3	21	33	48	85
Allowable load inertia moment		kg·m <sup>2</sup>	2.4	6.3	10	14	25
		kgf·cm·s <sup>2</sup>	24	64	100	144	260

Actuator model			FHA-32C				
			50	80	100	120	160
Reduction ratio		-	50:1	80:1	100:1	120:1	160:1
Max. rotational speed	200V	rpm	80	50	40	33	25
	100V		64	40	32	26	20
Actuator inertia moment		kg·m <sup>2</sup>	1.8	4.5	7.1	10.2	18.1
		kgf·cm·s <sup>2</sup>	18	46	72	104	185
Allowable load inertia moment		kg·m <sup>2</sup>	5.4	13	21	30	54
		kgf·cm·s <sup>2</sup>	55	133	210	306	550

Actuator model		FHA-40C					
		50	80	100	120	160	
Reduction ratio	-	50:1	80:1	100:1	120:1	160:1	
Max. rotational speed	200V	rpm	70	43	35	29	22
Actuator inertia moment		kg·m <sup>2</sup>	4.9	12.5	19.5	28.1	50
		kgf·cm·s <sup>2</sup>	50	128	200	287	510
Allowable load inertia moment		kg·m <sup>2</sup>	15	37	60	84	150
		kgf·cm·s <sup>2</sup>	150	378	610	860	1500

Sold & Serviced By:



Toll Free Phone (877) SERV098

Toll Free Fax (877) SERV099

[www.electromate.com](http://www.electromate.com)

[sales@electromate.com](mailto:sales@electromate.com)

## 2-2 Variable load inertia

FHA-C series actuators include HarmonicDrive® gearing that has a high reduction ratio. Because of this, the effects of change in load inertia moment on the servo performance are minimal. In comparison to direct servo drive mechanisms, therefore, this benefit allows the load to be driven with a better servo response.

For example, assume that the load inertia moment increases to N-times. The total inertia moment converted to motor shaft which has an effect on servo response is as follows:

The symbols in the formulas are:

- $J_s$  : Total inertia moment converted to motor shaft
- $J_M$  : Inertia moment of motor
- $R$  : Reduction ratio of FHA-C series actuator
- $L$  : Ratio of load inertia moment to inertia moment of motor
- $N$  : Rate of change in load inertia moment

- Direct drive

$$\text{Before: } J_s = J_M(1+L) \quad \text{After: } J_s' = J_M(1+NL) \quad \text{Ratio: } J_s'/J_s = \frac{1+NL}{1+L}$$

- Driven by FHA-C series

$$\text{Before: } J_s = J_M \left( 1 + \frac{L}{R^2} \right) \quad \text{After: } J_s' = J_M \left( 1 + \frac{NL}{R^2} \right) \quad \text{Ratio: } J_s'/J_s = \frac{1+NL/R^2}{1+L/R^2}$$

In the case of the FHA-C series, this is an extremely large number, such as  $R = 50$  to  $R = 160$ , that is  $R^2 = 2500$  to  $R^2 = 25600$ . Then the ratio is  $J_s'/J_s \approx 1$ . This means that FHA-C drive systems are hardly affected by the load variation.

Therefore, it is not necessary to take change in load inertia moment into consideration when selecting an FHA-C series actuator or setting up the initial driver parameters.

## 2-3 Verifying and examining load weights

The FHA-C series actuator incorporates a precise cross roller bearing for directly supporting an external load (output flange). To demonstrate the full ability of the actuator, verify the maximum load weight as well as the life and static safety coefficient of the cross roller bearing.

2

Selection

### Checking procedure

#### 1 Verify maximum load weight ( $M_{max}$ , $F_{rmax}$ , $F_{amax}$ )

Determine maximum load weight ( $M_{max}$ ,  $F_{rmax}$ ,  $F_{amax}$ )

↓

Verify that maximum load weight ( $M_{max}$ ,  $F_{rmax}$ ,  $F_{amax}$ )  $\leq$  than permissible load ( $M_c$ ,  $F_r$ ,  $F_a$ )

#### 2 Verifying life

Calculate the average radial load ( $F_{rav}$ ) and average axial load ( $F_{aav}$ ).

↓

Calculate the radial load coefficient ( $X$ ) and the axial load coefficient ( $Y$ ).

↓

Calculate the life of the bearing and verify the life is allowable.

#### 3 Verifying the static safety coefficient

Calculate the static equivalent radial load ( $P_o$ ).

↓

Verify the static safety coefficient ( $f_s$ ).

### Specifications of the main roller bearing

The following table shows the specifications of the main roller bearings built in FHA-C actuators.

Table 1: Specifications of the main roller bearings

Item	Circular pitch of the roller (dp)	Offset amount (R)	Basic dynamic rated load (C)	Basic static rated load (Co)	Permissible radial load (Fr)	Permissible axial load (Fa)	Permissible moment capacity (Mc)
Model	mm	mm	N	N	N	N	N·m
FHA-17C	77.0	17.0	10800	18700	2940	9800	188
FHA-25C	96.2	18.0	18000	33300	4900	14700	370
FHA-32C	112.2	18.5	24100	44300	9500	24500	530
FHA-40C	148.8	26.5	44900	88900	14700	39200	690



## Maximum load weights

How to calculate the maximum load weights ( $M_{max}$ ,  $F_{rmax}$ ,  $F_{amax}$ ) is explained below.

Confirm that each maximum load weight is equal to or less than each permissible load.

◆ **Formula (1): Maximum load weights**

$$M_{max} = \frac{F_{rmax} \cdot (L_r + R) + F_{amax} \cdot L_a}{1000}$$

Symbols used in the formula

$M_{max}$	Maximum moment capacity	N · m	
$F_{rmax}$	Max. radial load	N	Refer to Fig.1.
$F_{amax}$	Max. axial load	N	Refer to Fig.1.
$L_r, L_a$		mm	Refer to Fig.1.
$R$	Offset amount	mm	Refer to Fig.1 and Table 1.

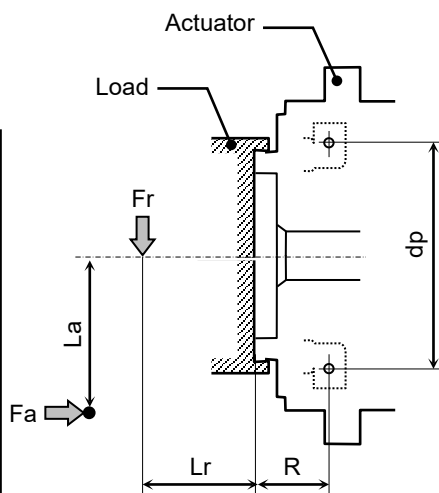

Fig. 1: External load action diagram

## Verifying life

### Calculating average loads (average radial and axial loads, average output rotational speed)

When the radial and/or axial loads vary during motion, calculate and verify the life of the cross roller bearing converting the loads to their average values.

◆ **Formula (2): Average radial load ( $F_{rav}$ )**

$$F_{rav} = \sqrt[10/3]{\frac{n_1 t_1 |F_{r1}|^{10/3} + n_2 t_2 |F_{r2}|^{10/3} + \dots + n_n t_n |F_{rn}|^{10/3}}{n_1 t_1 + n_2 t_2 + \dots + n_n t_n}}$$

The maximum radial load in section  $t_1$  is given by  $F_{r1}$ , while the maximum radial load in section  $t_3$  is given by  $F_{r3}$ .

◆ **Formula (3): Average axial load ( $F_{aav}$ )**

$$F_{aav} = \sqrt[10/3]{\frac{n_1 t_1 |F_{a1}|^{10/3} + n_2 t_2 |F_{a2}|^{10/3} + \dots + n_n t_n |F_{an}|^{10/3}}{n_1 t_1 + n_2 t_2 + \dots + n_n t_n}}$$

The maximum axial load in section  $t_1$  is given by  $F_{a1}$ , while the maximum axial load in section  $t_3$  is given by  $F_{a3}$ .

◆ **Formula (4): Average output rotational speed ( $N_{av}$ )**

$$N_{av} = \frac{n_1 t_1 + n_2 t_2 + \dots + n_n t_n}{t_1 + t_2 + \dots + t_n}$$

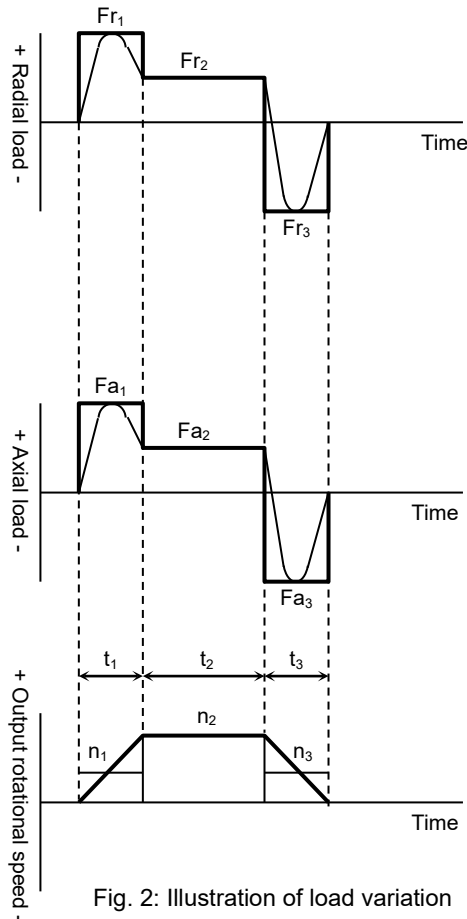

Fig. 2: Illustration of load variation

## Radial load coefficient and axial load coefficient

Table 2: Radial load coefficient (X), axial load coefficient (Y)

◆ Formula (5)	X	Y
$\frac{F_{rav}}{F_{rav} + 2(F_{rav}(L_r + R) + F_{aav} \cdot La)/dp} \leq 1.5$	1	0.45
$\frac{F_{rav}}{F_{rav} + 2(F_{rav}(L_r + R) + F_{aav} \cdot La)/dp} > 1.5$	0.67	0.67

### Symbols used in the formulas

$F_{rav}$	Average radial load	N	Obtained by formula (2).
$F_{aav}$	Average axial load	N	Obtained by formula (3).
$L_r, La$	—	mm	Refer to Fig.1.
R	Offset amount	mm	Refer to Fig.1 and Table 1.
dp	Pitch circle diameter of a roller	mm	Refer to Fig.1 and Table 1.

## Dynamic equivalent radial load

### ◆ Formula (6): Dynamic equivalent radial load

$$P_c = X \cdot \left( F_{rav} + \frac{2(F_{rav}(L_r + R) + F_{aav} \cdot La)}{dp} \right) + Y \cdot F_{aav}$$

### Symbols used in the formulas

$P_c$	Dynamic equivalent radial load	N	
$F_{rav}$	Average radial load	N	Obtained by formula (2).
$F_{aav}$	Average axial load	N	Obtained by formula (3).
dp	Pitch circle diameter of a roller	mm	Refer to Fig.1 and Table 1.
X	Radial load coefficient	—	Refer to Table 2.
Y	Axial load coefficient	—	Refer to Table 2.
$L_r, La$	—	mm	Refer to Fig.1.
R	Offset amount	mm	Refer to Fig.1 and Table 1.

## Life of cross roller bearing

Calculate the life of cross roller bearing with the formula (7):

### ◆ Formula (7): Cross roller bearing life

$$L_{B-10} = \frac{10^6}{60 \times N_{av}} \times \left( \frac{C}{f_w \cdot P_c} \right)^{10/3}$$

### Symbols used in the formulas

$L_{B-10}$	Life	hour	—
$N_{av}$	Average output rotational speed	r/min	Obtained by formula (4).
C	Basic dynamic rated load	N	Refer to Table 1.
$P_c$	Dynamic equivalent radial load	N	Obtained by formula (6).
$f_w$	Load coefficient	—	Refer to Table 3.

Table 3: Load coefficient

Loaded state	$f_w$
Smooth operation free from impact/vibration	1 to 1.2
Normal operation	1.2 to 1.5
Operation subject to impact/vibration	1.5 to 3

### Cross roller bearing life based on oscillating movement

Use formula (8) to calculate the cross roller bearing life against oscillating movement.

◆ **Formula (8): Cross roller bearing life (oscillating)**

$$L_{oc} = \frac{10^6}{60 \times n_1} \times \frac{90}{\theta} \times \left( \frac{C}{f_w \cdot P_c} \right)^{10/3}$$

Symbols used in the formulas

$L_{oc}$	Life	hour	—
$n_1$	Number of reciprocating oscillation per min.	cpm	—
$C$	Basic dynamic rated load	N	Refer to Table 1.
$P_c$	Dynamic equivalent radial load	N	Obtained by formula (6).
$f_w$	Load coefficient	—	Refer to Table 3.
$\theta$	oscillating angle/2	—	Refer to Fig. 3.

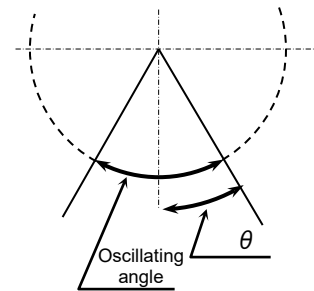

Fig. 3: Oscillating movement

If the oscillating angle is 5° or less, fretting wear may occur because oil film does not form effectively on the contact surface between the race and rolling element of the cross roller bearing. In such cases, consult HDS.

## Verifying static safety coefficients

### Static equivalent radial load

◆ **Formula (9): Static equivalent radial load**

$$P_o = F_{rmax} + \frac{2M_{max}}{d_p} + 0.44F_{amax}$$

Symbols used in the formulas

$F_{rmax}$	Max. radial load	N	Refer to Fig.1.
$F_{amax}$	Max. axial load	N	Refer to Fig.1.
$M_{max}$	Max. moment load	N·m	Obtained by formula (1).
$d_p$	Pitch circle diameter of a roller	mm	Refer to Fig.1 and Table 1.

### Static safety coefficient

Generally, the static equivalent load is limited by the basic static rated load ( $C_o$ ). However, the specific limit should be calculated according to the using conditions and required conditions. In this case, calculate the static safety coefficient ( $f_s$ ) by formula (10).

Table 4 shows general values representing using conditions. Calculate the static equivalent radial load ( $P_o$ ) by formula (9).

◆ **Formula (10): Static safety coefficient**

$$f_s = \frac{C_o}{P_o}$$

Symbols used in the formulas

$f_s$	Static safety coefficient	—	Refer to Table 4.
$C_o$	Basic static rated load	N	Refer to Table 1.
$P_o$	Static equivalent radial load	N	Obtained by formula (9).

Table 4: Static safety coefficients

Using conditions	$f_s$
High rotational accuracy is required, etc.	$\geq 3$
Operation subject to impact/vibration	$\geq 2$
Normal operation	$\geq 1.5$

## 2-4 Examining operating status

When the operation pattern (duty cycle) is such that the actuator starts and stops repeatedly, starting current and braking current flow through the motor at high frequency and the actuator generates heat. Therefore, the duty cycle must be examined.

The study is as follows:

### Examining actuator rotation speed

Calculate the required rotation speed (rpm) of the load driven by the FHA-C series.

For linear operation, use the rotation speed conversion formula below:

$$\text{Rotation speed (r/min)} = \frac{\text{Linear travel speed (mm/min)}}{\text{Screw feed pitch (mm)}}$$

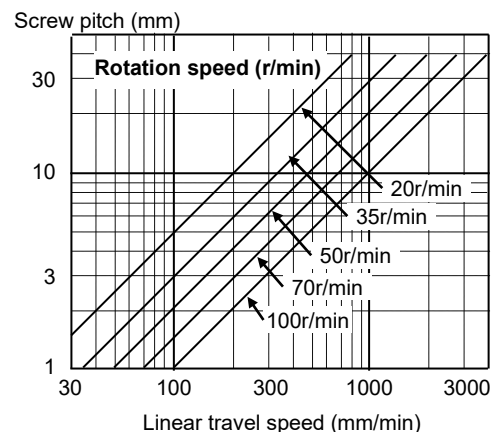

Select an appropriate reduction ratio from 50, 80, 100, 120, and 160 so that the calculated rotation speed does not exceed the maximum rotational speed of the FHA-C series actuator.

### Calculating and examining load inertia moment

Calculate the load inertia moment of the load driven by the FHA-C series actuator.

Refer to [A-2 Calculating inertia moment] (P5-3) for the calculation.

Based on the calculated result, tentatively select a FHA-C series actuator by referring to [Allowable load inertia moment] (P2-1).

Sold & Serviced By:



Toll Free Phone (877) SERV098

Toll Free Fax (877) SERV099

[www.electromate.com](http://www.electromate.com)

[sales@electromate.com](mailto:sales@electromate.com)

## Load torque calculation

Calculate the load torque as follows:

- Rotary motion

The rotary torque for the rotating mass  $W$  on the ring of radius  $r$  from the center of rotation is shown in the figure to the right.

$$T = 9.8 \times \mu \times W \times r$$

$T$  : Rotary torque (Nm)

$\mu$  : Friction coefficient

$W$  : Mass (kg)

$r$  : Average radius of friction side (m)

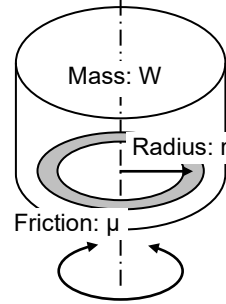

- Linear operation (horizontal operation)

The rotary torque when the mass  $W$  moves horizontally due to the screw of pitch  $P$  is shown below.

$$T = 9.8 \times \mu \times W \times \frac{P}{2 \times \pi}$$

$T$  : Rotary torque (Nm)

$\mu$  : friction coefficient

$W$  : mass (kg)

$P$  : Screw feed pitch (m)

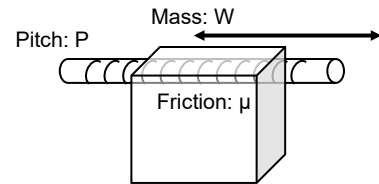

- Linear operation (vertical operation)

The rotary torque when the mass  $W$  moves vertically due to the screw of pitch  $P$  is shown below.

$$T = 9.8 \times W \times \frac{P}{2 \times \pi}$$

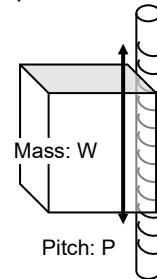

## Acceleration time and deceleration time

Calculate acceleration and deceleration times for the selected actuator.

$$\text{Acceleration time: } t_a = k \times (J_A + J_L) \times \frac{2 \times \pi}{60} \times \frac{N}{T_M - T_L}$$

$$\text{Deceleration time: } t_d = k \times (J_A + J_L) \times \frac{2 \times \pi}{60} \times \frac{N}{T_M + 2 \times T_F + T_L}$$

$t_a$ : Acceleration time (s)  
 $t_d$ : Deceleration time (s)

$k$ : Acceleration reduction coefficient 1 to 1.5

The total positioning time may become shorter if the acceleration is lowered for the purpose of reducing the settling time after positioning.

$J_A$ : Actuator inertia moment (kg·m<sup>2</sup>)

$J_L$ : Load inertia moment (kg·m<sup>2</sup>)

$N$ : Actuator rotation speed (rpm)

$T_M$ : Maximum actuator torque (N·m)

$T_F$ : Actuator friction torque (N·m)

$$T_F = K_T \times I_R - T_R$$

$K_T$ : Torque constant (N·m/A)

$T_R$ : Allowable continuous torque (N·m)

$I_R$ : Allowable continuous current (A)

$T_L$ : Load torque (Nm); The polarity is positive (+) when the torque is applied in the rotation direction, or negative (-) when it is applied in the opposite direction.

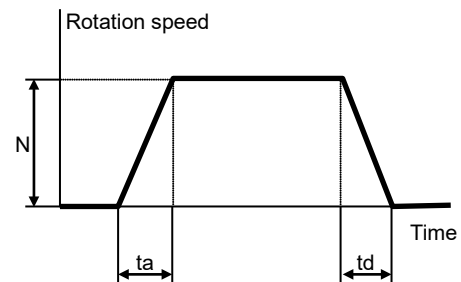

### ● Calculation example 1

Select an actuator that best suits the following operating conditions:

- Rotation speed: 60 r/min
- Load inertia moment: 1.5 kg·m<sup>2</sup>
- Since the load mechanism is mainly inertia, the load torque is negligibly small.

- (1) After applying these conditions to the graph in [2-1], FHA-25C-50 is tentatively selected.
- (2) From the rated table in 1-4, the following values are obtained:  $J_A = 0.81 \text{ kg} \cdot \text{m}^2$ ,  $T_M = 150 \text{ N} \cdot \text{m}$ ,  $K_T = 22 \text{ N} \cdot \text{m}/\text{A}$ ,  $I_R = 7.3 \text{ A}$ .
- (3) Based on the above formula, the actuator's friction torque  $T_F$  is calculated as  $22 \times 7.3 - 150 = 10.6 \text{ N} \cdot \text{m}$ .
- (4) Therefore, the acceleration time and deceleration time can be obtained as follows from the above formulas:
 
$$t_a = (0.81 + 1.5) \times 2 \times \pi / 60 \times 60 / 150 = 0.097 \text{ s}$$

$$t_d = (0.81 + 1.5) \times 2 \times \pi / 60 \times 60 / (150 + 2 \times 10.6) = 0.085 \text{ s}$$
- (5) If the calculated acceleration/deceleration times are too long, correct the situation by:
  - Reducing load inertia moment
  - Selecting an actuator with a larger frame size

## Examining effective torque and average rotation speed

One way to check if the heat generated from the actuator during operation would present a problem is to determine if the point of operation, determined by the effective torque and average rotation speed, is inside the continuous motion range explained in [1-13 Operable range] (P1-18).

Using the following formula, calculate the effective torque  $T_m$  and average rotation speed  $N_{av}$  when the actuator is operated repeatedly in the drive pattern shown to the right.

$$T_m = \sqrt{\frac{T_a^2 \times (t_a + t_d) + T_r^2 \times t_r}{t}}$$

$$N_{av} = \frac{N/2 \times t_a + N \times t_r + N/2 \times t_d}{t}$$

- $T_a$  : Acceleration time from speed 0 to N (s)
- $t_d$  : Deceleration time from speed N to 0 (s)
- $t_r$  : Operation time at constant speed N (s)
- $t$  : Cycle time (s)
- $T_m$  : Effective torque (Nm)
- $T_a$  : Max. torque (Nm)
- $T_r$  : Load torque (Nm)
- $N_{av}$  : Average rotation speed (rpm)
- $N$  : Rotation speed at constant speed (rpm)

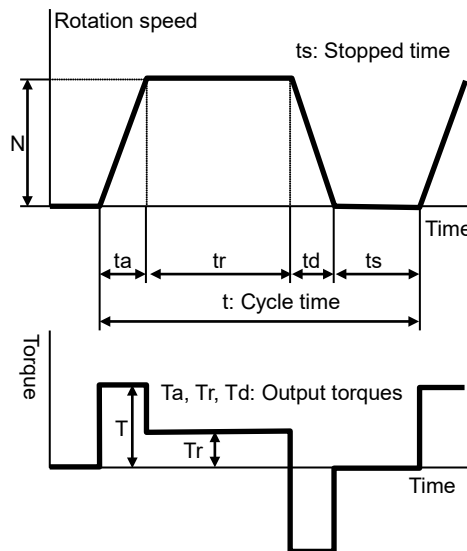

### ● Calculation example 2

An example of FHA-25C-50 is explained.

Operating conditions: Accelerate an inertia load and then let it move at a constant speed, followed by deceleration, based on conditions similar to those used in calculation example 1. The travel angle per cycle is 120° and the cycle time is 2 second.

(1) The travel angle is calculated from the area of the rotation speed vs. time diagram shown above. In other words, the travel angle is calculated as follows:

$$\theta = (N / 60) \times \{t_r + (t_a + t_d) / 2\} \times 360$$

Accordingly,  $t_r = \theta / (6 \times N) - (t_a + t_d) / 2$

When  $\theta = 120^\circ$ , and  $t_a = 0.097$  (s),  $t_d = 0.085$  (s),  $N = 60$  (r/min) in calculation example 1, are applied to this formula,  $t_r$  is calculated as 0.243 (s).

(2) Calculate the effective torque. Apply the values in (1), and  $T_a = 150$  (Nm),  $T_r = 0$  (Nm), and  $t = 2$  (s), to the above formulas.

$$T_m = \sqrt{\frac{150^2 \times (0.097 + 0.085)}{2.0}} = 45 \text{ Nm}$$

(3) Calculate the average rotation speed. Apply the values in (1), and  $N = 60$  (rpm-) and  $t = 2$  (s), to the above formulas.

$$N_{av} = \frac{60/2 \times 0.097 + 60 \times 0.243 + 60/2 \times 0.085}{2} = 10 \text{ r/min}$$

Sold & Serviced By:



Toll Free Phone (877) SERV098

Toll Free Fax (877) SERV099

www.electromate.com

sales@electromate.com

(4) The figure on the right shows the points of operation determined by the effective torque and average rotation speed calculated above, plotted on the graph of operable range of FHA-25C-50, exceeding the continuous motion range. The conclusion is that this actuator cannot be operated continuously under these conditions. Accordingly,

- ◆ the operation pattern
- ◆ load (possible reduction)
- ◆ actuator model No.

etc., must be reexamined.

The following formula is a modified version of the formula for effective torque. By applying the value of allowable continuous torque to  $T_m$  in this formula, the allowable cycle time can be calculated.

$$t = \frac{T_a^2 \times (t_a + t_d) + T_r^2 \times t_r}{T_m^2}$$

Apply the following:  $T_a = 150 \text{ Nm}$ ,  $T_r = 0 \text{ Nm}$ ,  $T_m = 35 \text{ Nm}$ ,  $t_a = 0.097 \text{ s}$ ,  $t_r = 0.243 \text{ s}$ ,  $t_d = 0.085 \text{ s}$ . Then, the following equation is obtained:

$$t = 150^2 \times (0.097 + 0.085) / 35^2 = 3.34 \text{ s}$$

Based on the result, setting the cycle time to 3.4 seconds or more to provide a longer stopped time gives  $T_m = 35 \text{ Nm}$  or less, thereby permitting continuous operation within the allowable continuous torque.

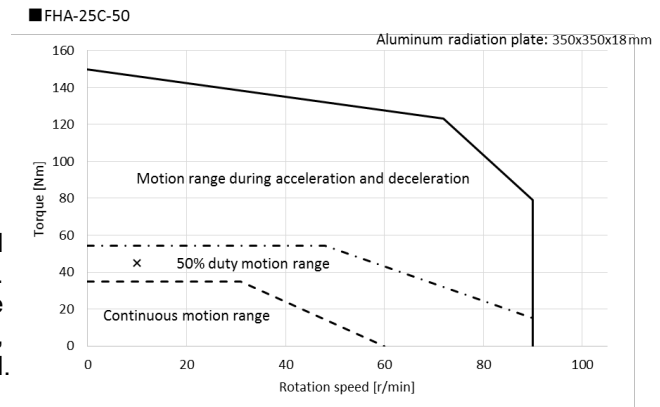

Operable range of FHA-25C-50

**Caution**

- The aforementioned continuous motion range represents an allowable range where the actuator installed on a specified aluminum radiation plate is operated under natural air cooling. If the radiation area of the mounting member is small or heat conduction of the material is poor, adjust the operating conditions to keep the rise in the actuator's ambient temperature to 40 K or less as a guide.



**2**

**Selection**

# Chapter 3

## Actuator installation

---

The following explains the installation procedures of the actuators.

---

3-1 Receiving Inspection .....	3-1
3-2 Notices on handling .....	3-2
3-3 Location and installation .....	3-3

Sold & Serviced By:



Toll Free Phone (877) SERV098

Toll Free Fax (877) SERV099

[www.electromate.com](http://www.electromate.com)

[sales@electromate.com](mailto:sales@electromate.com)

# 3-1 Receiving Inspection

Check the following items after unpacking the package.

## Inspection procedure

**1 Check the items thoroughly for damage sustained during transportation.**

If any item is damaged, immediately contact the dealer.

**2 Check if the actuator is what you ordered.**

The nameplate is found on the side of the FHA-C series actuator. Check the TYPE field on the nameplate to confirm that it is indeed the model you have ordered. If any item is wrong, immediately contact the dealer.

Refer to the [1-2 **Ordering Code**] (P1-2) in this manual for details of the model codes.



**Only connect the actuator to a proper servo drive.**

Wrong combinations of drivers and actuators may cause low torque problems or overcurrent that may cause burned damage to the actuator, injury or fire.



**Do not connect a supply voltage other than the voltage specified on the driver label.**

Connecting a power supply not matching the input voltage specified on the nameplate may result in damage to the driver, injury or fire.

## 3-2 Notices on handling

Handle the FHA-C series actuator carefully by observing the notices specified below.



- (1) Do not apply any excessive force or impact, especially to the actuator's output shaft.
- (2) Do not put the FHA-C series actuator on a table, shelf, etc., where the actuator could easily fall.
- (3) Do not connect the actuator terminals directly to the power supply. The actuator may burn and cause fire or electric shock.
- (4) The allowable storage temperature is  $-20$  to  $+60^{\circ}\text{C}$ . Do not expose the actuator to direct sunlight for long periods of time or store it in areas in low or high temperature.
- (5) The allowable relative storage humidity is 80% or less. Do not store the actuator in a very humid place or in areas where temperatures are likely to fluctuate greatly during day and night.
- (6) Do not use or store the actuator in locations subject to corrosive gases or dust particles.

# 3-3 Location and installation

## Environment of location

The environmental conditions of the installation location for FHA-C series actuators must be as follows. Determine an appropriate installation location by observing these conditions without fail.

- ◆ Operating temperature: 0 to 40°C  
 The temperature in the cabinet may be higher than the atmosphere depending on the power loss of housed devices and size of the cabinet. Plan the cabinet size, cooling system, and device locations so the ambient temperature of the actuator is kept 40°C or below.
- ◆ Operating humidity: Relative humidity of 20 to 80%.  
 Make sure no condensation occurs. Take note that condensation is likely to occur in a place where there is a large temperature change between day and night or when the actuator is started/stopped frequently.
- ◆ Vibration: 24.5 m/s<sup>2</sup> (2.5G) (10 to 400Hz) or less  
 Actuator operation is not guaranteed in applications where impact is constantly applied.
- ◆ Impact: 294 m/s<sup>2</sup> (30G) or less  
 Actuator operation is not guaranteed in applications where impact is constantly applied.
- ◆ Use environment: Free from dust, condensation, metal powder, corrosive gases, water, oil mist, etc.
- ◆ Protection class: Standard products are structurally designed to meet the IP-4 4 requirements.

The protection class against water entry is as follows:  
 4: Protected against water splashed from all directions.

The protection class against contact and entry of foreign matter is as follows:  
 4: Protected against solid bodies of superior dimensions to 1 mm.

However, this does not apply to 1) rotating and sliding areas (oil seal areas), 2) cable disconnection areas, 3) option connectors, and 4) option sensor areas.

- ◆ Locate the driver indoors or within an enclosure. Do not expose it to the sunlight.
- ◆ Altitude: lower than 1000 m above sea level
- ◆ The oil seals in rotating and sliding areas do not fully prevent leakage of lubricant. If the actuator is used in a clean room, etc., provide additional oil leakage prevention measures.

## Installation

The FHA-C series actuator drives mechanical load system at high accuracy. When installing the actuator, pay attention to precision and do not tap the actuator output part with a hammer, etc. The actuator houses an encoder. Excessive impact may damage the encoder.

### Installation procedure

#### 1 Align the axis of rotation of the actuator and the load mechanism precisely.

Note: Perform this alignment carefully, especially when a rigid coupling is used. Even slight misalignment may cause the permissible load of the actuator to be exceeded, resulting in damage to the output shaft.

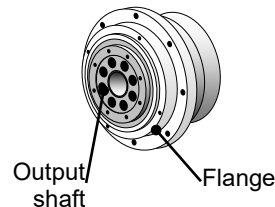

#### 2 Use flat washers and high-tension bolts to fasten the actuator flange to the load machine. Tighten them with a torque wrench to control the tightening torque.

Tightening torques are shown in the table below.

Item		FHA-17C		FHA-25C		FHA-32C		FHA-40C	
		Output shaft	Flange	Output shaft	Flange	Output shaft	Flange	Output shaft	Flange
Tightening torque	Screw, hole depth	6-M5 Depth 8	6-M5	8-M6 Depth 10	8-M6	16-M6 Depth 10	12-M6	8-M10 Depth 15	8-M10
	N·m	5	3	12	7	12	7	45	25
	kgf·cm	50	30	120	70	120	70	450	250

#### 3 For details on wiring, refer to the manual of your HA-800 driver.

#### 4 Wire the motor cable and encoder cable.

Do not pull the cables with a strong force. The connection points may be damaged. Install the cable with slack not to apply tension to the actuator. Provide a sufficient bending radius ( $R = 40$  mm or more), especially when the cable flexes.



#### Do not apply torque, load or thrust to the sleeve directly.

The sleeve (hollow shaft) is adhered to the output rotary shaft. Accordingly, the adhered sleeve may be detached from the output rotary shaft if a torque or load is applied to the sleeve (hollow shaft). Do not apply any torque, moment load or thrust load directly to the sleeve (hollow shaft).

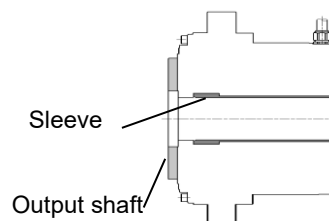

#### Do not disassemble/reassemble the actuator.

The actuator uses many precision parts. Drops in accuracy and performance due to disassembly and assembly by the customer are not covered by the warranty.

Sold & Serviced By:



Toll Free Phone (877) SERV098

Toll Free Fax (877) SERV099

[www.electromate.com](http://www.electromate.com)

[sales@electromate.com](mailto:sales@electromate.com)

# Chapter 4

## Options

---

This chapter explains the options available for the FHA-C series actuator.

---

4-1 Specifications for 100 VAC input power supply (option code: A) .....	4-1
4-2 Motor shaft holding brake (option code: B) .....	4-7
4-3 With connector (option code: C) .....	4-9
4-4 Cable length: 5 m (option code: F5) .....	4-10
4-5 Cable taken out from rear face (option code: K) .....	4-11
4-6 Revolution sensor (origin & end limit) (option code: L) .....	4-12
4-7 Specifications for high accuracy (option code: PR) .....	4-15
4-8 Extension cables .....	4-17



# 4-1 Specifications for 100VAC power supply (option code: A)

Specifications for FHA-C series actuators with 100VAC input power supply option are shown below.

Item	Model	FHA-17C				
		50	80	100	120	160
Input power supply	V	AC100				
Combined driver		HA-800□-3C-100				
Max. torque <sup>*1</sup>	N·m	39	51	57	60	64
Allowable continuous torque <sup>*1*2</sup>	N·m	15	20	24	24	24
Max. rotation speed <sup>*1</sup>	rpm	96	60	48	40	30
Torque constant <sup>*1</sup>	N·m/A <sub>rms</sub>	11	17	21	25	33
Max. current <sup>*1</sup>	A <sub>rms</sub>	4.2	3.4	3.2	2.7	2.2
Allowable continuous current <sup>*1*2</sup>	A <sub>rms</sub>	1.9	1.7	1.5	1.3	1.0
MEF constant <sup>*3</sup>	V/(rpm)	1.2	1.9	2.4	2.8	3.8
Phase resistance	Ω(20°C)	2				
Phase inductance	mH	1.5				
Inertia moment (GD <sup>2</sup> /4)	kg·m <sup>2</sup>	0.17	0.43	0.67	0.97	1.7
Inertia moment (J)	kgf·cm·s <sup>2</sup>	1.7	4.4	6.9	10	17
Reduction ratio	-	1:50	1:80	1:100	1:120	1:160
Allowable radial load	kN	2.94				
Allowable axial load	kN	9.8				
Allowable moment load	N·m	188				
Moment stiffness	N·m/rad	220 x 10 <sup>3</sup>				
	kgf·m/arc min	6.5				
One-way positional accuracy	Sec.	60	40	40	40	40
Motor position detector	Pulse/rev.	2500				
Output shaft resolution (multiplied by 4) <sup>*4</sup>	Pulse/rev.	500000	800000	1000000	1200000	1600000
Mass	kg	2.5				
Protection structure		Totally enclosed self-cooled type (IP44)				
Environmental conditions		Operating temperature: 0 to 40°C/Storage temperature: -20 to 60°C Operating humidity/storage humidity: 20 to 80%RH (no condensation) Resistance to vibration: 24.5 m/s <sup>2</sup> (frequency: 10 to 400Hz)/Shock resistance: 294 m/s <sup>2</sup> No dust, no metal powder, no corrosive gas, no inflammable gas, no oil mist To be used indoors, no direct sunlight Altitude: less than 1000 m above sea level				
Motor insulation		Insulation resistance: 100MΩ or more (by DC500V insulation tester) Dielectric strength: AC1500V/1 min Insulation class: F				
Mounting direction		Can be installed in any direction.				

The table shows typical output values of actuators.

\*1: When combined with a HA-800 driver. (Ambient temperature 25°C)

\*2: Value after temperature rise and saturation when the 300 x 300 x 15 [mm] aluminum radiation plate is installed.

\*3: Value of the phase-induced voltage constant multiplied by 3.

\*4: The output shaft resolution is (motor shaft encoder resolution when multiplied by 4) x (reduction ratio).

Item	Model	FHA-25C				
		50	80	100	120	160
Input power supply	V	AC100				
Combined driver		HA-800□-6C-100				
Max. torque <sup>*1</sup>	N·m	150	213	230	247	260
Allowable continuous torque <sup>*1,2</sup>	N·m	32	55	70	85	85
Max. rotation speed <sup>*1</sup>	rpm	90	56	45	37	28
Torque constant <sup>*1</sup>	N·m/A <sub>rms</sub>	11	17	22	26	36
Max. current <sup>*1</sup>	A <sub>rms</sub>	15	13	11	10	8.0
Allowable continuous current <sup>*1,2</sup>	A <sub>rms</sub>	4.0	4.0	4.0	4.0	3.2
EMF constant <sup>*3</sup>	V/(rpm)	1.3	2.0	2.6	2.9	4.1
Phase resistance	Ω(20°C)	0.65				
Phase inductance	mH	0.65				
Inertia moment (GD <sup>2</sup> /4)	kg·m <sup>2</sup>	0.81	2.1	3.2	4.7	8.3
Inertia moment (J)	kgf·cm·s <sup>2</sup>	8.3	21	33	48	85
Reduction ratio	-	1:50	1:80	1:100	1:120	1:160
Allowable radial load	kN	4.9				
Allowable axial load	kN	14.7				
Allowable moment load	N·m	370				
Moment stiffness	N·m/rad	490 x 10 <sup>3</sup>				
	kgf·m/arc min	15				
One-way positional accuracy	Sec.	40	30	30	30	30
Motor position detector	Pulse/rev.	2500				
Output shaft resolution (multiplied by 4) <sup>*4</sup>	Pulse/rev.	500000	800000	1000000	1200000	1600000
Mass	kg	4.0				
Protection structure		Totally enclosed self-cooled type (IP44)				
Environmental conditions		Operating temperature: 0 to 40°C/Storage temperature: -20 to 60°C Operating humidity/storage humidity: 20 to 80%RH (no condensation) Resistance to vibration: 24.5 m/s <sup>2</sup> (frequency: 10 to 400Hz)/Shock resistance: 294 m/s <sup>2</sup> No dust, no metal powder, no corrosive gas, no inflammable gas, no oil mist To be used indoors, no direct sunlight Altitude: less than 1000 m above sea level				
Motor insulation		Insulation resistance: 100MΩ or more (by DC500V insulation tester) Dielectric strength: AC1500V/1 min Insulation class: F				
Mounting direction		Can be installed in any direction.				

The table shows typical output values of actuators.

\*1: When combined with a HA-800 driver. (Ambient temperature 25°C)

\*2: Value after temperature rise and saturation when the 350 x 350 x 18 [mm] aluminum radiation plate is installed.

\*3: Value of the phase-induced voltage constant multiplied by 3.

\*4: The output shaft resolution is (motor shaft encoder resolution when multiplied by 4) x (reduction ratio).

4-1 Specifications for 100VAC power supply (option code: A)

Item	Model	FHA-32C				
		50	80	100	120	160
Input power supply	V	AC100				
Combined driver		HA-800□-6C-100				
Max. torque <sup>*1</sup>	N·m	227	364	398	432	453
Allowable continuous torque <sup>*1'2</sup>	N·m	32	55	75	91	125
Max. rotation speed <sup>*1</sup>	rpm	64	40	32	26	20
Torque constant <sup>*1</sup>	N·m/A <sub>rms</sub>	16	26	33	39	52
Max. current <sup>*1</sup>	A <sub>rms</sub>	18	16	16	12	12
Allowable continuous current <sup>*1'2</sup>	A <sub>rms</sub>	4.0	4.0	4.0	4.0	4.0
EMF constant <sup>*3</sup>	V/(rpm)	1.5	2.9	3.0	4.4	4.8
Phase resistance	Ω(20°C)	0.38				
Phase inductance	mH	0.49				
Inertia moment (GD <sup>2</sup> /4)	kg·m <sup>2</sup>	1.8	4.5	7.1	10.2	18.1
Inertia moment (J)	kgf·cm·s <sup>2</sup>	18	46	72	104	185
Reduction ratio	-	1:50	1:80	1:100	1:120	1:160
Allowable radial load	kN	9.5				
Allowable axial load	kN	24.5				
Allowable moment load	N·m	530				
Moment stiffness	N·m/rad	790 x 10 <sup>3</sup>				
	kgf·m/arc min	23				
One-way positional accuracy	Sec.	40	30	30	30	30
Motor position detector	Pulse/rev.	2500				
Output shaft resolution (multiplied by 4) <sup>*4</sup>	Pulse/rev.	500000	800000	1000000	1200000	1600000
Mass	kg	6.5				
Protection structure		Totally enclosed self-cooled type (IP44)				
Environmental conditions		Operating temperature: 0 to 40°C/Storage temperature: -20 to 60°C Operating humidity/storage humidity: 20 to 80%RH (no condensation) Resistance to vibration: 24.5 m/s <sup>2</sup> (frequency: 10 to 400Hz)/Shock resistance: 294 m/s <sup>2</sup> No dust, no metal powder, no corrosive gas, no inflammable gas, no oil mist To be used indoors, no direct sunlight Altitude: less than 1000 m above sea level				
Motor insulation		Insulation resistance: 100MΩ or more (by DC500V insulation tester) Dielectric strength: AC1500V/1 min Insulation class: F				
Mounting direction		Can be installed in any direction.				

The table shows typical output values of actuators.

\*1: When combined with a HA-800 driver. (Ambient temperature 25°C)

\*2: Value after temperature rise and saturation when the 400 x 400 x 20 [mm] aluminum radiation plate is installed.

\*3: Value of the phase-induced voltage constant multiplied by 3.

\*4: The output shaft resolution is (motor shaft encoder resolution when multiplied by 4) x (reduction ratio).

■ FHA-17C-50

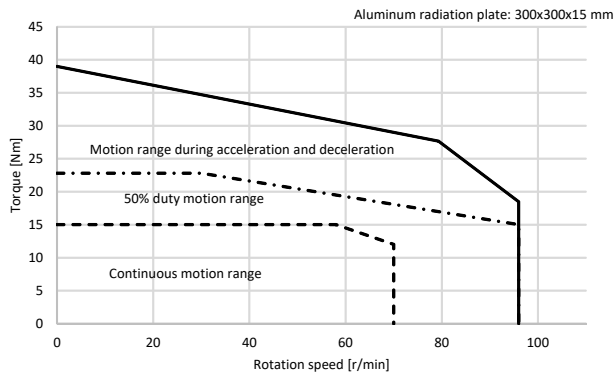

■ FHA-17C-80

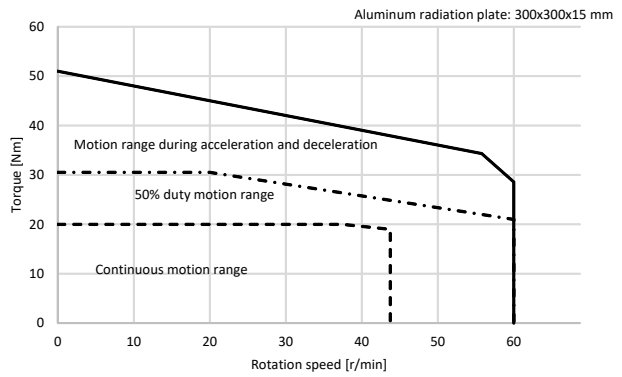

■ FHA-17C-100

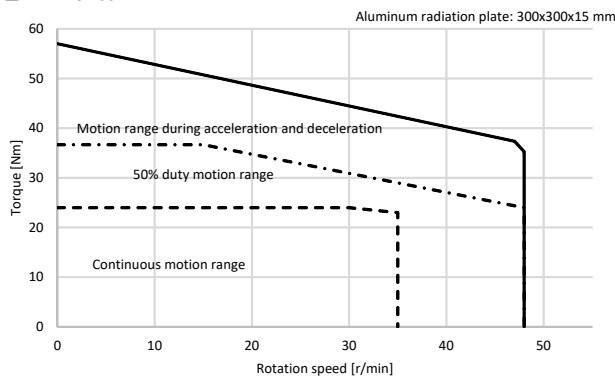

■ FHA-17C-120

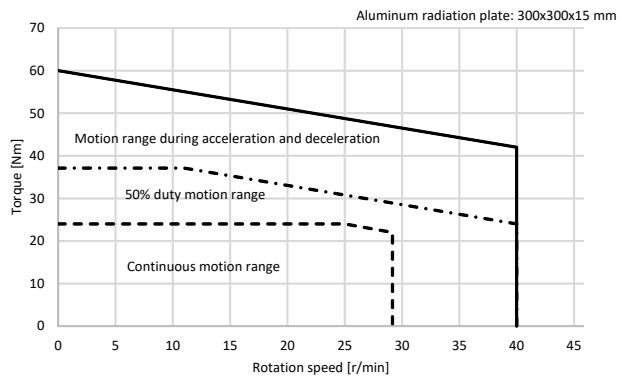

■ FHA-17C-160

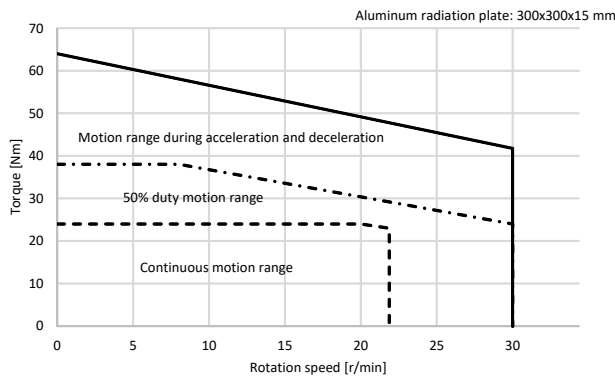

Sold & Serviced By:



Toll Free Phone (877) SERV098

Toll Free Fax (877) SERV099

[www.electromate.com](http://www.electromate.com)

[sales@electromate.com](mailto:sales@electromate.com)

## 4-1 Specifications for 100VAC power supply (option code: A)

4

Options

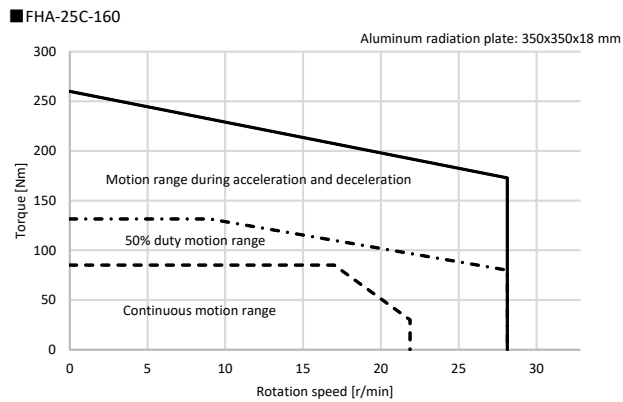
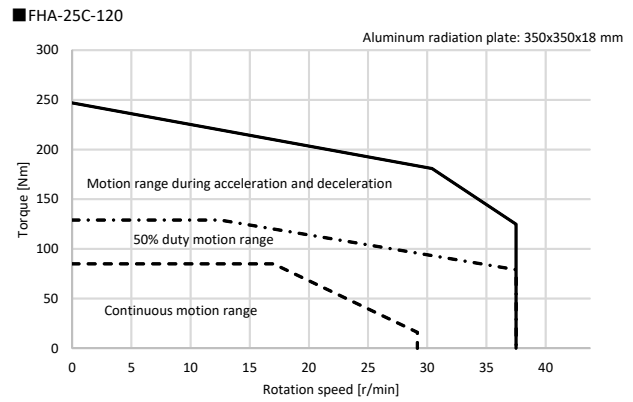
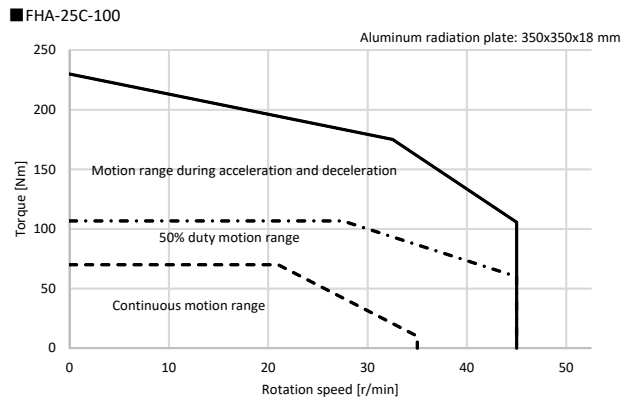
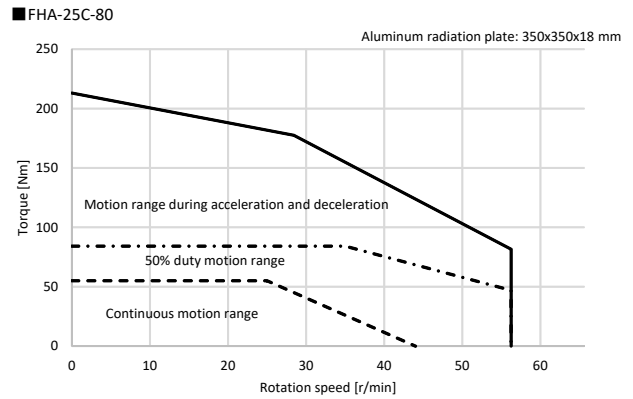
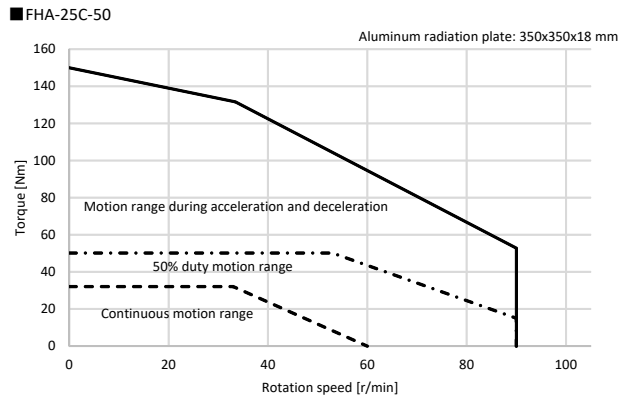

## 4-1 Specifications for 100VAC power supply (option code: A)

■ FHA-32C-50

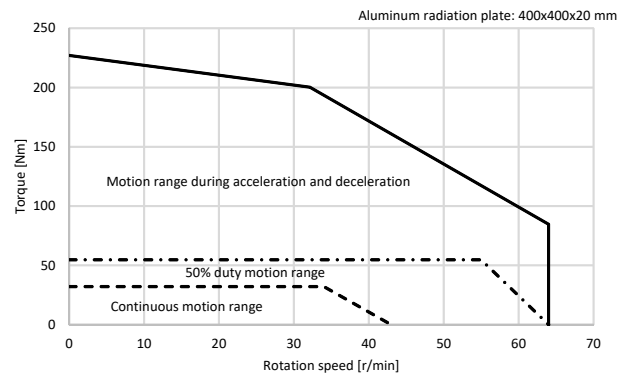

■ FHA-32C-80

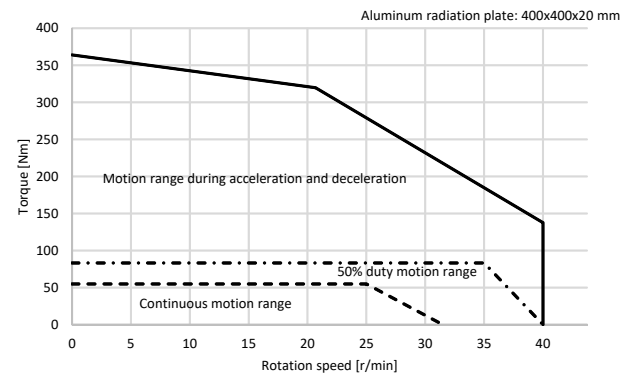

■ FHA-32C-100

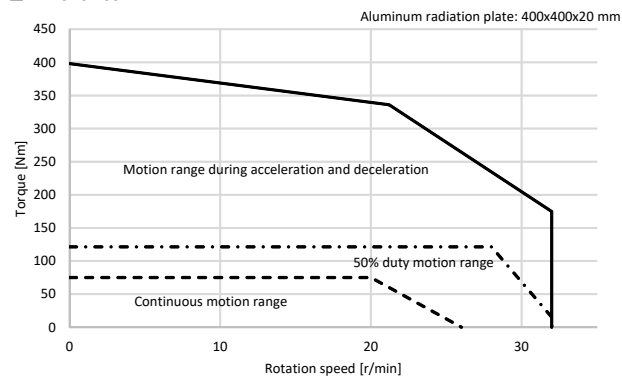

■ FHA-32C-120

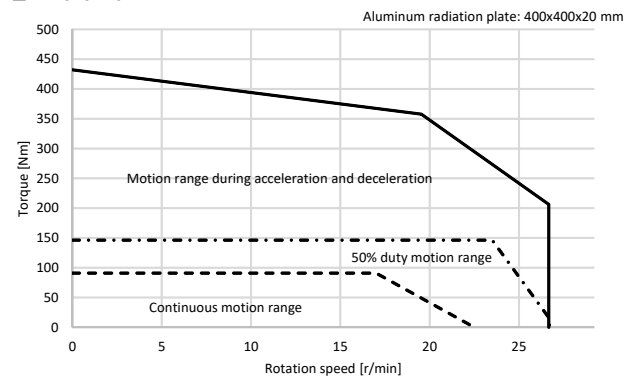

■ FHA-32C-160

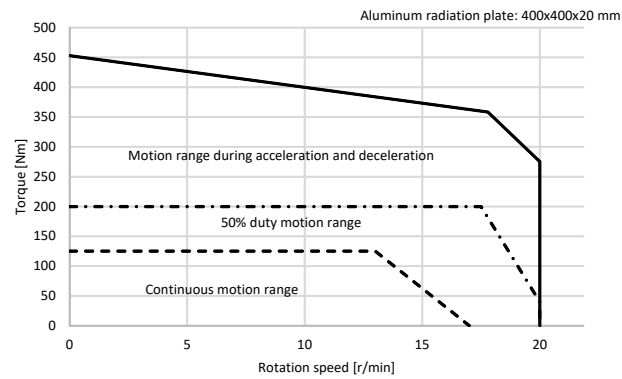

## 4-2 Motor shaft holding brake (option code: B)

FHA-C series actuators can be equipped with motor shaft holding brakes.

FHA-C series brakes incorporate two coils: one for absorption and one for holding. The actuator's built-in circuit controls the voltage and reduces the power consumption during retention.

Be sure to use a DC power supply having proper brake excitation voltage and capable of outputting enough current consumption during suction.

### Motor shaft holding brake specifications

Item	Model	FHA-17C					FHA-25C				
		50	80	100	120	160	50	80	100	120	160
Type		Dry non-excitation actuation type (Power-saving control via absorption and retention coils)									
Brake excitation voltage	V	DC24V±10% (no polarity) <sup>Note1</sup>									
Current consumption during suction (at 20°C) <sup>Note 2</sup>	A	1.0					1.1				
Current consumption during holding (at 20°C)	A	0.15					0.15				
Holding torque <sup>Note 3</sup>	N·m	24	39	49	59	78	49	79	98	118	157
	kgf·m	2.5	4	5	6	8	5	8	10	12	16
Inertia moment <sup>Note 3</sup> (Actuator total)	(GD <sup>2</sup> /4) kg·m <sup>2</sup>	0.24	0.61	0.96	1.4	2.5	1.0	2.6	4.1	6.0	10.6
	(J) kgf·cm·s <sup>2</sup>	2.4	6.3	9.8	14	25	10	27	42	61	110
Mass <sup>Note 4</sup>	kg	2.9					4.8				
Allowable number of normal brakings <sup>Note 5</sup>		100000 times									
Allowable number of emergency stops <sup>Note 6</sup>		200 times									

Item	Model	FHA-32C					FHA-40C				
		50	80	100	120	160	50	80	100	120	160
Type		Dry non-excitation actuation type (Power-saving control via absorption and retention coils)									
Brake excitation voltage	V	DC24V±10% (no polarity) <sup>Note1</sup>									
Current consumption during suction (at 20°C) <sup>Note 2</sup>	A	1.2					1.3				
Current consumption during holding (at 20°C)	A	0.2					0.25				
Holding torque <sup>Note 3</sup>	N·m	75	120	150	180	240	108	173	216	259	345
	kgf·m	7.7	12	15	18	24	11	18	22	26	35
Inertia moment <sup>Note 3</sup> (Actuator total)	(GD <sup>2</sup> /4) kg·m <sup>2</sup>	2.1	5.4	8.4	12	22	5.5	14	22	32	57
	(J) kgf·cm·s <sup>2</sup>	21	55	86	124	220	56	144	230	325	580
Mass <sup>Note 4</sup>	kg	7.4					14				
Allowable number of normal brakings <sup>Note 5</sup>		100000 times									
Allowable number of emergency stops <sup>Note 6</sup>		200 times									

Note 1: Power supply is user's responsibility. Use a power supply capable of outputting enough current consumption during suction for the brake.

Note 2: The duration for current consumption during suction is 0.5 second or less for the power supply of DC24V ± 10%.

Note 3: The values are converted for the output shaft.

Note 4: The values present total mass of the actuator.

Note 5: The service time for normal holding is assured when the brake activates at motor speed of 150 r/min or less.

Note 6: The service time for emergency stop is assured when the brake activates at motor speed of 3000 r/min or less.

**WARNING**

Do not use the holding brake more than the allowable number of normal brakings (100000 times at the motor shaft rotation speed of 150 rpm or less) or allowable number of emergency stops (200 times at the motor shaft rotation speed of 3000 r/min).

Exceeding the allowable number of normal brakings and allowable number of emergency stops may deteriorate holding torque, and may consequently become out of use as a brake.

## Motor shaft holding brake cable specifications

The brake cable and motor cable are combined into a single cable. Wire colors are shown in the table below.

Color	Cable
Red	Motor phase-U
White	Motor phase-V
Black	Motor phase-W
Green/Yellow	PE
Blue	Brake
Yellow	(no polarity)
(Shield)	FG



## 4-3 With connector (option code: C)

Connectors are attached to the ends of actuator cables. Use an extension cable to allow for convenient connections with HA-800 drivers.

Connectors are also effective as countermeasures against static electricity, for improved reliability during assembly.

- Connector models for motors: Molex Japan Co., Ltd.  
Receptacle: 5557-08R, female terminal: 5556PBTL
- Connector models for encoders: Binder  
99-2009-02-04

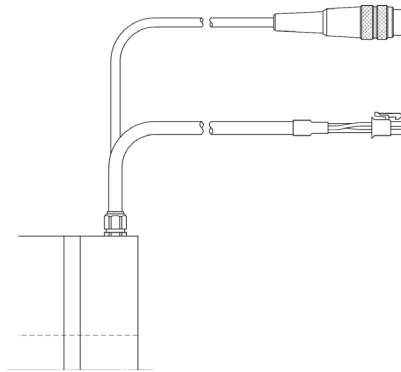

Recommended connector models on extension side (receiving side)

- Connector models for motors: Molex Japan Co., Ltd.  
Plug: 5559-08P, male terminal: 5558
- Connector models for encoders: Molex  
5557-16R

Sold & Serviced By:



Toll Free Phone (877) SERV098

Toll Free Fax (877) SERV099

[www.electromate.com](http://www.electromate.com)

[sales@electromate.com](mailto:sales@electromate.com)

## 4-4 Cable length: 5 m (option code: F5)

Actuator cables (motor and encoder wires) can be extended to a length of 5 m. Use this option when connections cannot be extended.

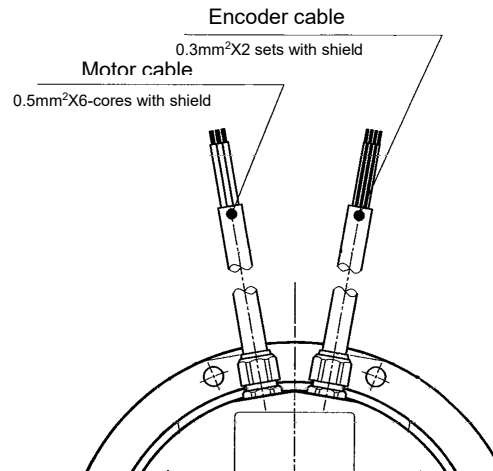

## 4-5 Rear exiting cable (option code: K)

The cables (motor and encoder wires) are taken out from the rear of the actuator. Use this option if the actuator is housed in a system and there is not enough space in the radial direction of the housing.

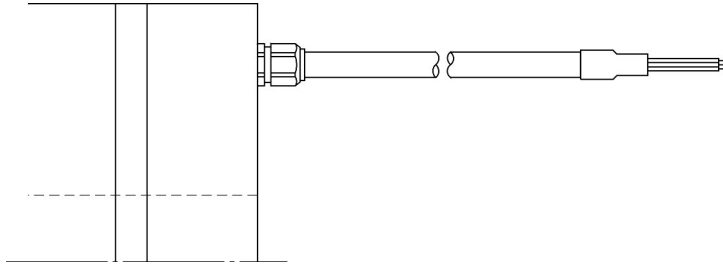

# 4-6 Rotary Position Sensor (option code: L)

Revolution sensors are directly connected to the output shaft on the counter-output side of the actuator. Use this option if the mechanical origin is needed or you want to define an operation range as a safety measure.

## Revolution sensor specifications

4

Options

### Origin sensor

Model: EE-SX672 [OMRON Corporation]

- **Sensor connection diagram**

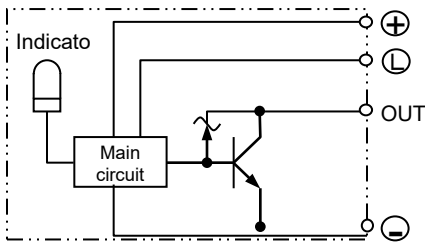

Operating status: ON when light is blocked/ON when light enters (switchable)

Normally turns ON when light is blocked, but short circuiting the (L) terminal and (+) terminal switches the system to turn ON when light enters.

Input voltage: DC5 to 24V ± 10%, ripple (p-p) 10% or less

Current consumption: 35 mA or less

Control output: NPN open collector output DC5 to 24V, load current (Ic) 100 mA, residual voltage (Vce) 0.8V or less  
For TTL drive, load current (Ic) 40 mA, residual voltage (Vce) 0.4V or less

- **Time chart**

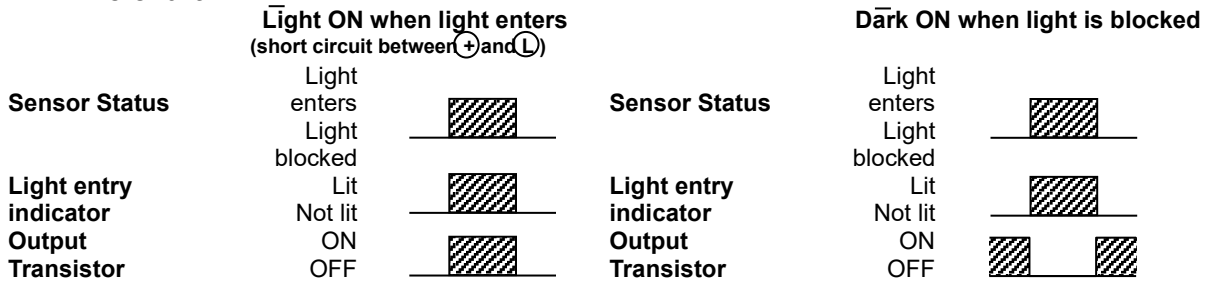

- **Limit switch (limit 1, 2)**

Model: D2JW-01K21 [OMRON Corporation]

· Switch contact type

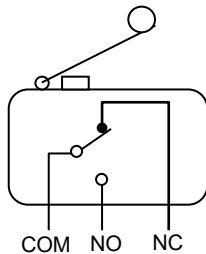

Electricity rating: DC30V 100 mA resistance load

Allowable operations

Frequency: 240/min (mechanical), 60/min (electric)

Life: 1000000 or more (mechanical), 100000 or more (electric)

\* For details, refer to OMRON Corporation catalogs.

## Sensor adjustment method

The method for adjusting sensors is shown below:

- (1) Loosen the fixing screws from the origin slit board and limit 1/2 targets. (Until the targets can be turned easily by hand.)
- (2) Adjust the position of the limit 2 target, set the clockwise (CW) limit position, then fasten the fixing screw.
- (3) Adjust the position of the limit 1 target, set the counter-clockwise (CCW) limit position, then fasten the fixing screw.
- (4) To set the position of the origin slit board, rotate the actuator at a slow speed, pass current through the origin sensor, and confirm its ON/OFF signal to fix it in the appropriate position.

Caution 1: The unit is supplied with the origin slit board and limit 1/2 target fixing screws temporarily fastened. After setting the position, fasten them securely.

Caution 2: Locking measures are recommended after refastening fixing screws.

Caution 3: After adjusting the position of each sensor and fastening fixing screws, test the unit to make sure that the sensor operates at the desired position.

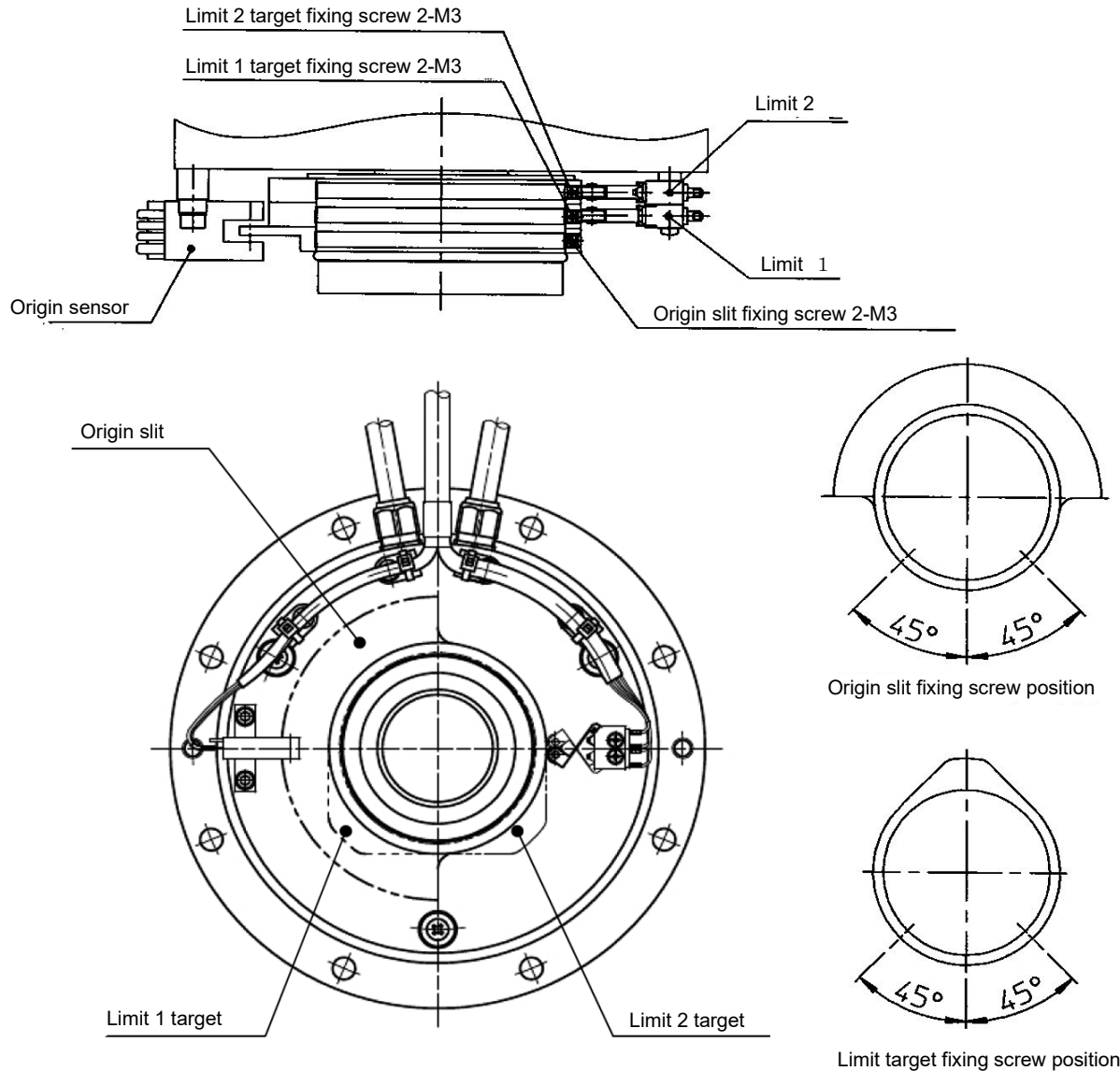

## Sensor drive range

### Limit 1, 2

- **FHA-17**

Limit 1 target maximum moveable range

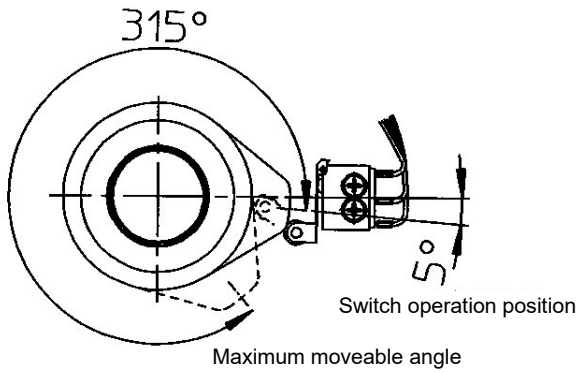

Limit 2 target maximum moveable range

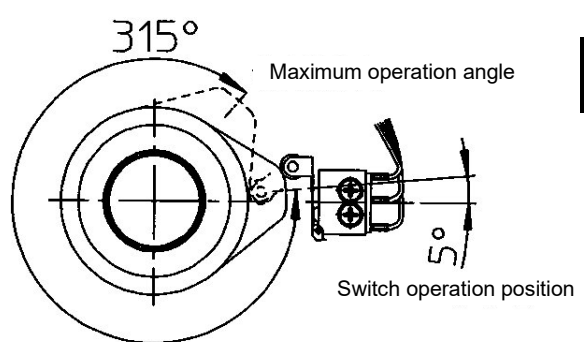

4

Options

- **FHA-25, 32, 40**

Limit 1 target maximum moveable range

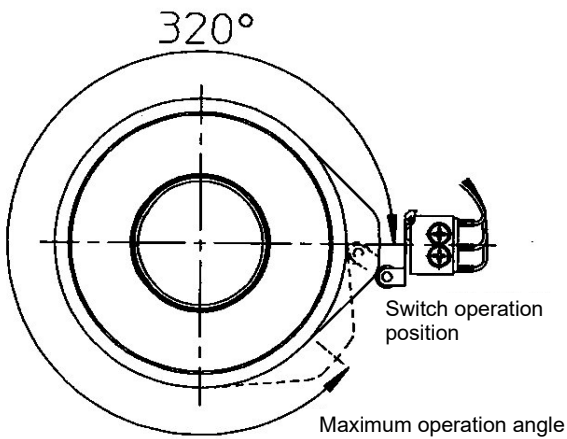

Limit 2 target maximum moveable range

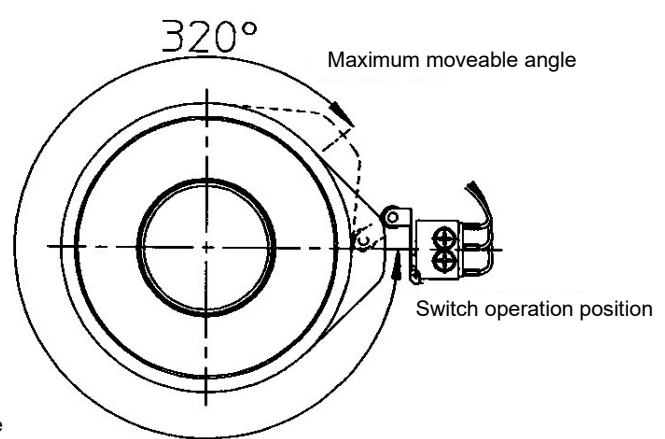

Caution: Driving the unit at or above the maximum angle listed above could damage the limit switch.

### Origin sensor

The sensor is contactless, so its drive range is unlimited.

## 4-7 Specifications for high accuracy (option code: PR)

The high accuracy option for the FHA-C series actuators delivers standardized repeatability and reverse positional accuracy, making actuators suitable for applications that require higher positional accuracy. Consider using this option for actuators in the mechanized parts used for alignment and other applications that require high accuracy.

● Repeatability (Unit: sec.)

Model	FHA-17C-PR	FHA-25C-PR	FHA-32C-PR	FHA-40C-PR
Reduction ratio				
50:1 to 160:1	±5	±5	±4	±4

● Bi-directional accuracy (Unit: sec.)

Model	FHA-17C-PR	FHA-25C-PR	FHA-32C-PR	FHA-40C-PR
Reduction ratio				
50:1	75	60	50	50
80:1 or more	30	25	20	20

● Inertia moment ( $GD^2/4$ ) (Unit:  $kg \cdot m^2$ )

Model	FHA-17C-PR	FHA-25C-PR	FHA-32C-PR	FHA-40C-PR
Reduction ratio				
50:1	0.21	0.90	2.1	5.5
80:1	0.53	2.3	5.3	14
100:1	0.83	3.5	8.2	22
120:1	1.2	5.2	12	32
160:1	2.1	9.2	21	56

● Inertia moment (J) (Unit:  $kgf \cdot cm \cdot s^2$ )

Model	FHA-17C-PR	FHA-25C-PR	FHA-32C-PR	FHA-40C-PR
Reduction ratio				
50:1	2.1	9	21	56
80:1	5.4	23	54	143
100:1	8.5	37	84	223
120:1	12	53	121	321
160:1	21	94	215	569

● Mass (Unit: kg)

Model	FHA-17C-PR	FHA-25C-PR	FHA-32C-PR	FHA-40C-PR
Reduction ratio				
50:1 to 160:1	2.8	4.7	7.1	13.6

For specifications for actuators without the high accuracy option, refer to the standard product specifications (P1-4) or specifications for actuators with the 100 VAC input power supply option (P4-1).

### External dimensions

The external dimensions of FHA-C-PR high accuracy actuators are the same as FHA-C series standard actuators except for dimensions L<sub>1</sub> and L<sub>2</sub> shown in the figure below. Refer to [1-5 External dimensions] (P1-8).

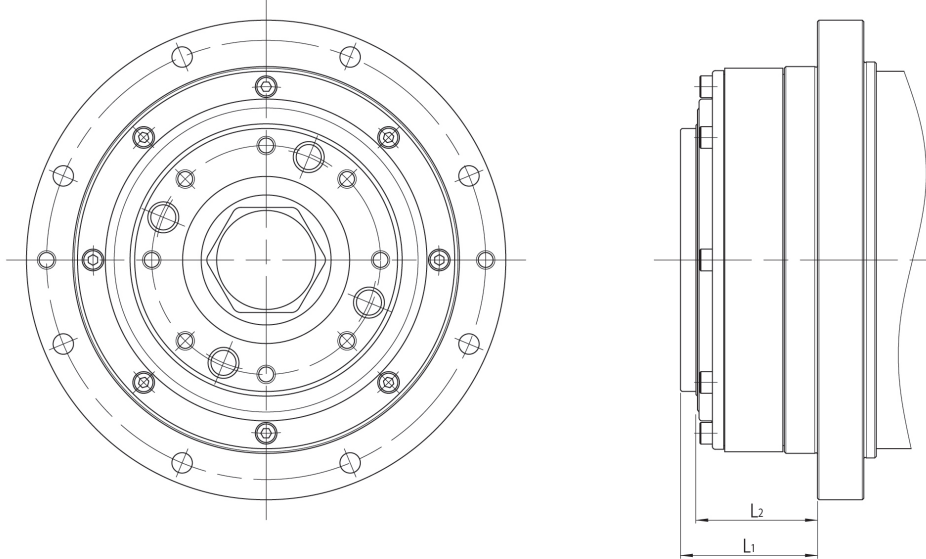

(Unit: mm)

Actuator model	FHA-17C-PR	FHA-25C-PR	FHA-32C-PR	FHA-40C-PR
Dimension L <sub>1</sub>	35	44.3	46	58.5
Dimension L <sub>2</sub>	29.5	39.3	41	51.5

### Mechanical accuracy

The mechanical accuracies of the output shaft and mounting flange for FHA-C-PR are shown below: (Unit: mm)

Accuracy items	FHA-17C-PR	FHA-25C-PR	FHA-32C-PR	FHA-40C-PR
1. Output shaft surface runout	0.010	0.012	0.012	0.014
2. Deflection of output shaft	0.010	0.012	0.012	0.014
3. Parallelism between the output shaft end mounted surface	0.040	0.050	0.050	0.060
4. Concentricity between the output shaft and fitting part	0.040	0.050	0.050	0.060

Note: All values are T.I.R. (Total Indicator Reading).

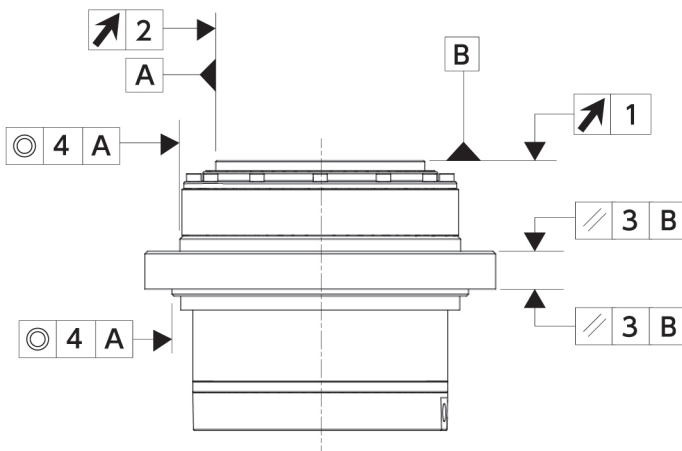



# 4-8 Extension cables

This extension cable is used to connect the FHA-C actuator to the HA-800 driver.  
 Extension cables are available for motors (including brake wire) and incremental encoders.  
 (Please provide your own cable for signal communication RS-232C.)

● **Extension cable model (\*\* indicates the cable length of 3 m, 5 m or 10 m.)**

(1) For motors:

EWC-MB\*\*-M08-TN3

Cable length (03 = 3 m, 05 = 5 m, 10 = 10 m)

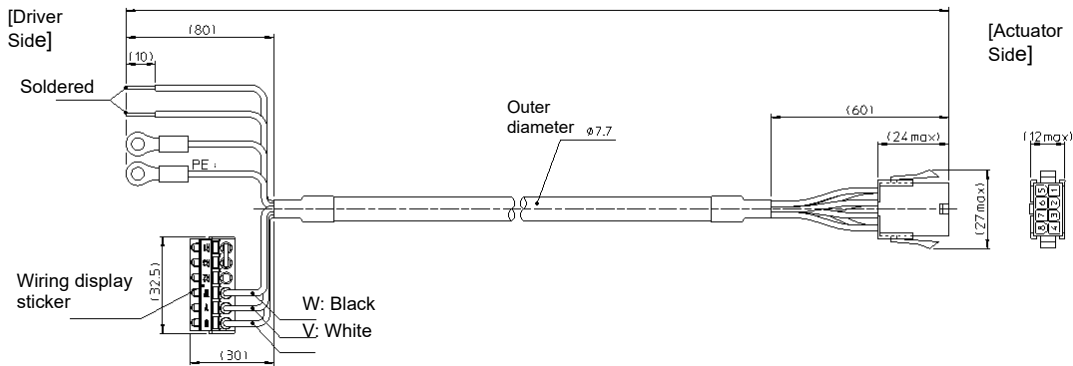

(2) For incremental encoders:

EWC-E\*\*-B04-3M14

Cable length (03 = 3 m, 05 = 5 m, 10 = 10 m)

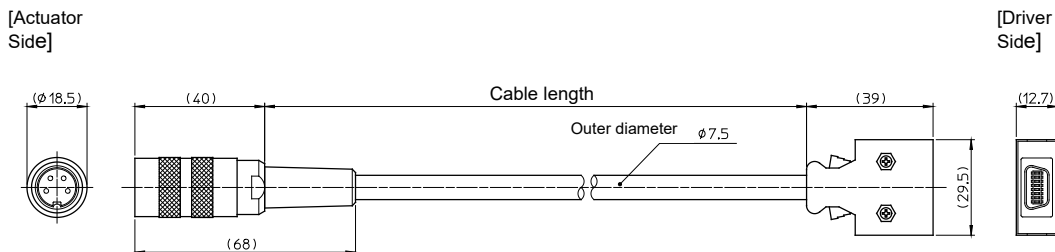

This extension cable is used to connect the FHA-C actuator to the HDLLC driver.

**Connector kit:** Ordering Code depends on the driver; please refer to the Data sheet.

**Communication cable:** Communication between driver and PC Via RS-232C

Ordering Code: SER-CK

● **Extension cable model (\*\* indicates the cable length of 3 m, 5 m or 10 m.)**

**Motor:**

EWC-MB\*\*  -M08-SP

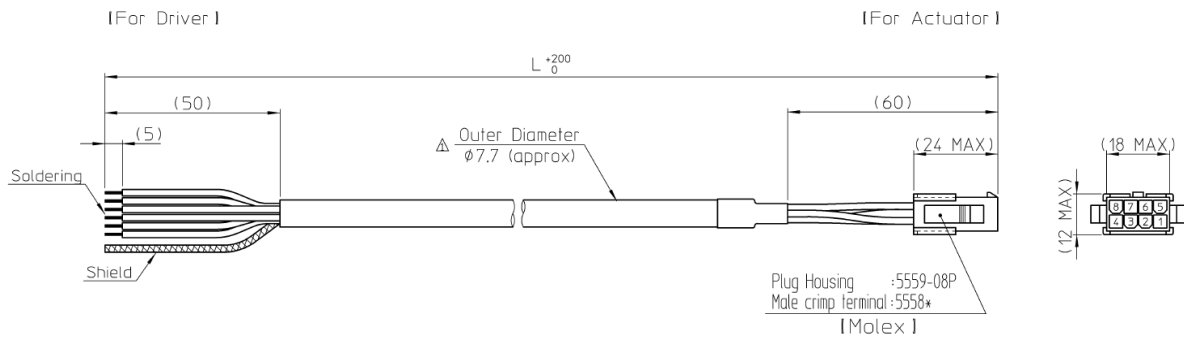

**Encoder:**

EWA-E\*\*  -M16-SP

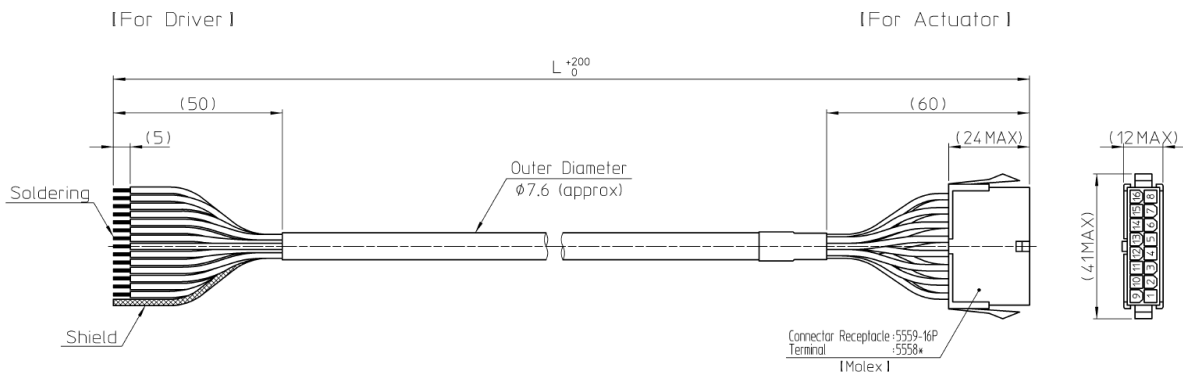

4

Options

Sold & Serviced By:



Toll Free Phone (877) SERV098

Toll Free Fax (877) SERV099

[www.electromate.com](http://www.electromate.com)

[sales@electromate.com](mailto:sales@electromate.com)

# Appendix

---

---

A-1 Unit conversion .....	5-1
A-2 Calculating inertia moment .....	5-3

# A-1 Unit conversion

This manual employs SI system for units. Conversion factors between the SI system and other systems are as follows:

**(1) Length**

SI system	m	
Unit	ft.	in.
Factor	3.281	39.37

**(2) Linear speed**

SI system	m/s			
Unit	m/min	ft./min	ft./s	in/s
Factor	60	196.9	3.281	39.37

**(3) Linear acceleration**

SI system	m/s <sup>2</sup>			
Unit	m/min <sup>2</sup>	ft./min <sup>2</sup>	ft./s <sup>2</sup>	in/s <sup>2</sup>
Factor	3600	1.18x10 <sup>4</sup>	3.281	39.37

**(4) Force**

SI system	N		
Unit	kgf	lb (force)	oz (force)
Factor	0.102	0.225	4.386

**(5) Mass**

SI system	kg	
Unit	lb.	oz.
Factor	2.205	35.27

**(6) Angle**

SI system	rad		
Unit	deg.	min.	sec.
Factor	57.3	3.44x10 <sup>3</sup>	2.06x10 <sup>5</sup>

**(7) Angular speed**

SI system	rad/s			
Unit	deg/s	deg/min	r/s	r/min
Factor	57.3	3.44x10 <sup>3</sup>	0.1592	9.55

Unit	ft.	in.
Factor	0.3048	0.0254
SI system	m	

Unit	m/min	ft./min	ft./s	in/s
Factor	0.0167	5.08x10 <sup>-3</sup>	0.3048	0.0254
SI system	m/s			

Unit	m/min <sup>2</sup>	ft./min <sup>2</sup>	ft./s <sup>2</sup>	in/s <sup>2</sup>
Factor	2.78 x10 <sup>-4</sup>	8.47x10 <sup>-5</sup>	0.3048	0.0254
SI system	m/s <sup>2</sup>			

Unit	kgf	lb (force)	oz (force)
Factor	9.81	4.45	0.278
SI system	N		

Unit	lb.	oz.
Factor	0.4535	0.02835
SI system	kg	

Unit	deg.	min.	sec.
Factor	0.01755	2.93x10 <sup>-4</sup>	4.88x10 <sup>-6</sup>
SI system	rad		

Unit	deg/s	deg/min	r/s	r/min
Factor	0.01755	2.93x10 <sup>-4</sup>	6.28	0.1047
SI system	rad/s			

**(8) Angular acceleration**

SI system	rad/s <sup>2</sup>	
↓		
Unit	deg/s <sup>2</sup>	deg/min <sup>2</sup>
Factor	57.3	3.44x10 <sup>3</sup>

Unit	deg/s <sup>2</sup>	deg/min <sup>2</sup>
Factor	0.01755	2.93x10 <sup>-4</sup>

SI system	rad/s <sup>2</sup>	
-----------	--------------------	--

**(9) Torque**

SI system	N·m			
↓				
Unit	kgf·m	lb·ft	lb·in	oz·in
Factor	0.102	0.738	8.85	141.6

Unit	kgf·m	lb·ft	lb·in	oz·in
Factor	9.81	1.356	0.1130	7.06x10 <sup>-3</sup>

SI system	N·m			
-----------	-----	--	--	--

**(10) Inertia moment**

SI system	kg·m <sup>2</sup>							
↓								
Unit	kgf·m·s <sup>2</sup>	kgf·cm·s <sup>2</sup>	lb·ft <sup>2</sup>	lb·ft·s <sup>2</sup>	lb·in <sup>2</sup>	lb·in·s <sup>2</sup>	oz·in <sup>2</sup>	oz·in·s <sup>2</sup>
Factor	0.102	10.2	23.73	0.7376	3.42x10 <sup>3</sup>	8.85	5.47x10 <sup>4</sup>	141.6

Unit	kgf·m·s <sup>2</sup>	kgf·cm·s <sup>2</sup>	lb·ft <sup>2</sup>	lb·ft·s <sup>2</sup>	lb·in <sup>2</sup>	lb·in·s <sup>2</sup>	oz·in <sup>2</sup>	oz·in·s <sup>2</sup>
Factor	9.81	0.0981	0.0421	1.356	2.93x10 <sup>-4</sup>	0.113	1.829x10 <sup>-5</sup>	7.06x10 <sup>-3</sup>

SI system	kg·m <sup>2</sup>							
-----------	-------------------	--	--	--	--	--	--	--

**(11) Torsional spring constant, moment stiffness**

SI system	N·m/rad				
↓					
Unit	kgf·m/rad	kgf·m/arc min	kgf·m/deg	lb·ft/deg	lb·in/deg
Factor	0.102	2.97 x10 <sup>-5</sup>	1.78x10 <sup>-3</sup>	0.0129	0.1546

Unit	kgf·m/rad	kgf·m/arc min	kgf·m/deg	lb·ft/deg	lb·in/deg
Factor	9.81	3.37 x10 <sup>4</sup>	562	77.6	6.47

SI system	N·m/rad				
-----------	---------	--	--	--	--

Sold &amp; Serviced By:



Toll Free Phone (877) SERV098

Toll Free Fax (877) SERV099

www.electromate.com

sales@electromate.com

# A-2 Calculating inertia moment

## Formula of mass and inertia moment

### (1) Both centerlines of rotation and gravity are the same:

The following table includes formulas to calculate mass and inertia moment.

$m$  : mass (kg),  $I_x, I_y, I_z$ : inertia moments which rotates around x-, y-, z-axes respectively ( $\text{kg} \cdot \text{m}^2$ )

$G$  : distance from end face of gravity center (m)

$\rho$  : density ( $\text{kg}/\text{m}^3$ )

Unit Length: m, Mass: kg, Inertia moment:  $\text{kg} \cdot \text{m}^2$

Apx

Appendix

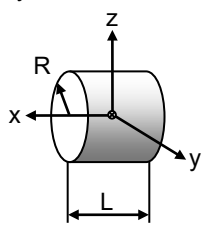
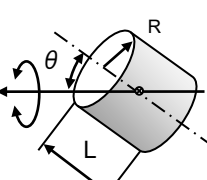
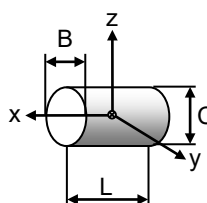
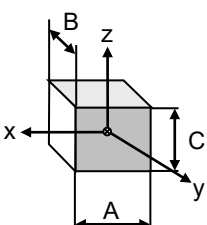
Object form	Mass, inertia, gravity center
	$m = \pi R^2 L \rho$ $I_x = \frac{1}{2} m R^2$ $I_y = \frac{1}{4} m \left( R^2 + \frac{L^2}{3} \right)$ $I_z = \frac{1}{4} m \left( R^2 + \frac{L^2}{3} \right)$
	$m = \pi R^2 L \rho$ $I_\theta = \frac{1}{12} m \times \left\{ 3R^2(1 + \cos^2\theta) + L^2 \sin^2\theta \right\}$
	$m = \frac{1}{4} B C L \rho$ $I_x = \frac{1}{16} m (B^2 + C^2)$ $I_y = \frac{1}{4} m \left( \frac{C^2}{4} + \frac{L^2}{3} \right)$ $I_z = \frac{1}{4} m \left( \frac{B^2}{4} + \frac{L^2}{3} \right)$
	$m = A B C \rho$ $I_x = \frac{1}{12} m (B^2 + C^2)$ $I_y = \frac{1}{12} m (C^2 + A^2)$ $I_z = \frac{1}{12} m (A^2 + B^2)$

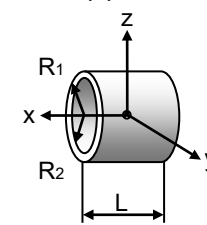
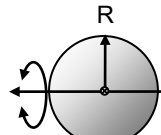
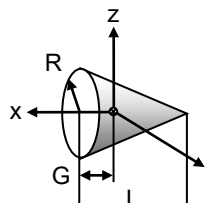
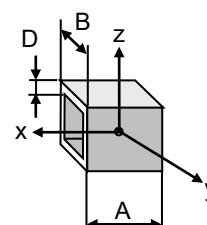
Object form	Mass, inertia, gravity center
	$m = \pi (R_1^2 - R_2^2) L \rho$ $I_x = \frac{1}{2} m (R_1^2 + R_2^2)$ $I_y = \frac{1}{4} m \left\{ (R_1^2 + R_2^2) + \frac{L^2}{3} \right\}$ $I_z = \frac{1}{4} m \left\{ (R_1^2 + R_2^2) + \frac{L^2}{3} \right\}$ <p>R1: Outer diameter R2: Inner diameter</p>
	$m = \frac{4}{3} \pi R^3 \rho$ $I = \frac{2}{5} m R^2$
	$m = \frac{1}{3} \pi R^2 L \rho$ $I_x = \frac{3}{10} m R^2$ $I_y = \frac{3}{80} m (4R^2 + L^2)$ $I_z = \frac{3}{80} m (4R^2 + L^2)$ $G = \frac{L}{4}$
	$m = 4AD(B - D)\rho$ $I_x = \frac{1}{3} m \left\{ (B \cdot D)^2 + D^2 \right\}$ $I_y = \frac{1}{6} m \left\{ \frac{A^2}{2} + (B \cdot D)^2 + D^2 \right\}$ $I_z = \frac{1}{6} m \left\{ \frac{A^2}{2} + (B \cdot D)^2 + D^2 \right\}$

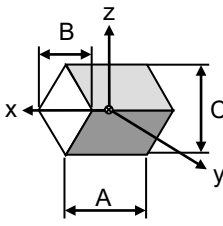
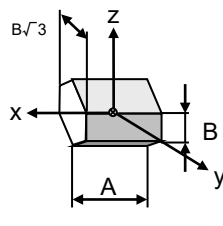
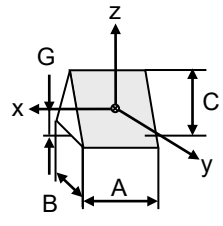
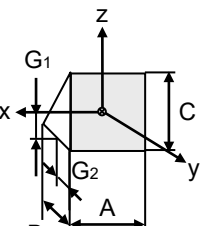
Object form	Mass, inertia, gravity center	Object form	Mass, inertia, gravity center
<p>Rhombus pillar</p> 	$m = \frac{1}{2} ABC\rho$ $I_x = \frac{1}{24} m(B^2 + C^2)$ $I_y = \frac{1}{24} m(C^2 + 2A^2)$ $I_z = \frac{1}{24} m(B^2 + 2A^2)$	<p>Hexagonal pillar</p> 	$m = \frac{3\sqrt{3}}{2} AB^2\rho$ $I_x = \frac{5}{12} mB^2$ $I_y = \frac{1}{12} m\left(A^2 + \frac{5}{2}B^2\right)$ $I_z = \frac{1}{12} m\left(A^2 + \frac{5}{2}B^2\right)$
<p>Isosceles triangle pillar</p> 	$m = \frac{1}{2} ABC\rho$ $I_x = \frac{1}{12} m\left(\frac{B^2}{2} + \frac{2}{3}C^2\right)$ $I_y = \frac{1}{12} m\left(A^2 + \frac{2}{3}C^2\right)$ $I_z = \frac{1}{12} m\left(A^2 + \frac{B^2}{2}\right)$ $G = \frac{C}{3}$	<p>Right triangle pillar</p> 	$m = \frac{1}{2} ABC\rho$ $I_x = \frac{1}{36} m(B^2 + C^2)$ $I_y = \frac{1}{12} m\left(A^2 + \frac{2}{3}C^2\right)$ $I_z = \frac{1}{12} m\left(A^2 + \frac{2}{3}B^2\right)$ $G_1 = \frac{C}{3} \quad G_2 = \frac{B}{3}$

● **Example of density**

The following tables show references of specific gravity. Confirm the specific gravity for the material of the drive load.

Material	Density (x10 <sup>3</sup> kg/m <sup>3</sup> )	Material	Density (x10 <sup>3</sup> kg/m <sup>3</sup> )	Material	Density (x10 <sup>3</sup> kg/m <sup>3</sup> )
SUS304	7.93	Aluminum	2.70	Epoxy resin	1.90
S45C	7.86	Duralumin	2.80	ABS	1.10
SS400	7.85	Silicon	2.30	Silicon resin	1.80
Cast iron	7.19	Quartz glass	2.20	Polyurethane rubber	1.25
Copper	8.92	Teflon	2.20		
Brass	8.50	Fluorocarbon resin	2.20		

**(2) Both centerlines of rotation and gravity are not the same:**

The following formula calculates the inertia moment when the rotary center is different from the gravity center.

$$I = I_g + mF^2$$

I: Inertia moment when the gravity center axis does not match the rotational axis (kg·m<sup>2</sup>)

I<sub>g</sub>: Inertia moment when the gravity center axis matches the rotational axis (kg·m<sup>2</sup>)

Calculate according to the shape by using formula (1).

m: mass (kg)

F: Distance between rotary center and gravity center (m)

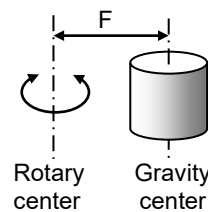

**(3) Inertia moment of linear operation objects**

The inertia moment, converted to actuator axis, of a linear motion object driven by a screw, etc., is calculated using the formula below.

$$I = m\left(\frac{P}{2\pi}\right)^2$$

I: Inertia moment of a linear operation object converted to actuator axis (kg·m<sup>2</sup>)

m: mass (kg)

P: Linear travel per actuator one revolution (m/rev)



## Inertia moment of cylinder

The inertia moment of a cylinder may be obtained from the graphs to the right.

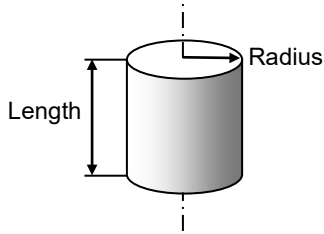

Apply the top graph to aluminum materials (specific gravity: 2.7) and bottom graph to steel materials (specific gravity: 7.85).

(Example)  
 Material: Aluminum  
 Outer diameter: 100 mm  
 Length: 7 mm  
 Shape: Column  
 Since the outer diameter is 100 mm, the radius is 50 mm. Therefore, the above graph gives the inertia moment as follows:  
 Approx.  $1.9 \times 10^{-4} \text{ kg} \cdot \text{m}^2$   
 (Calculated value:  $0.000186 \text{ kg} \cdot \text{m}^2$ )

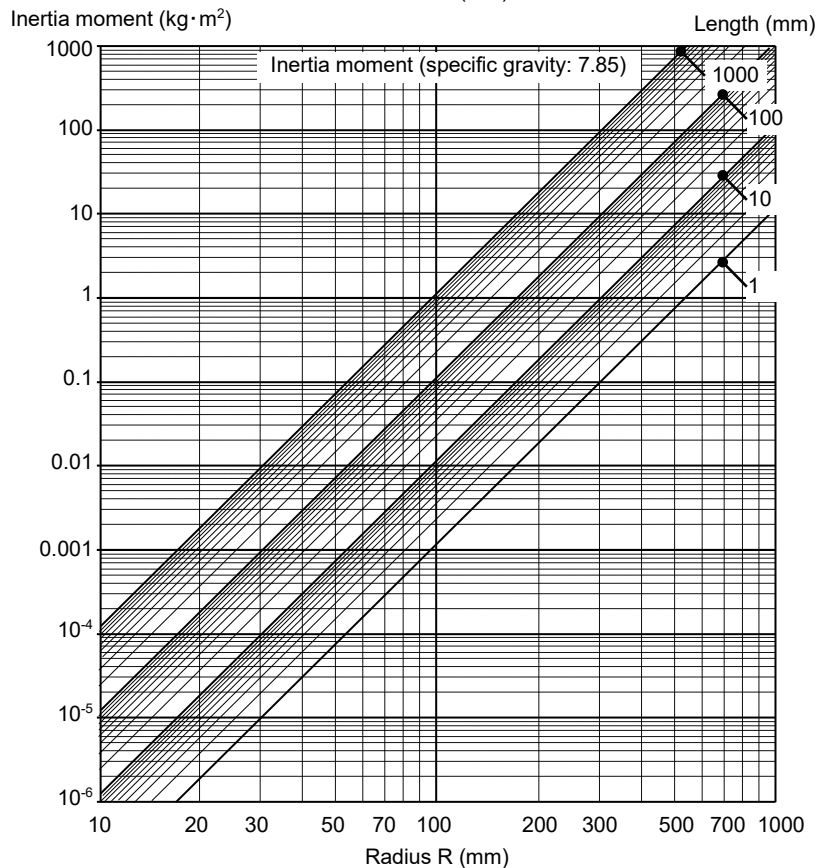
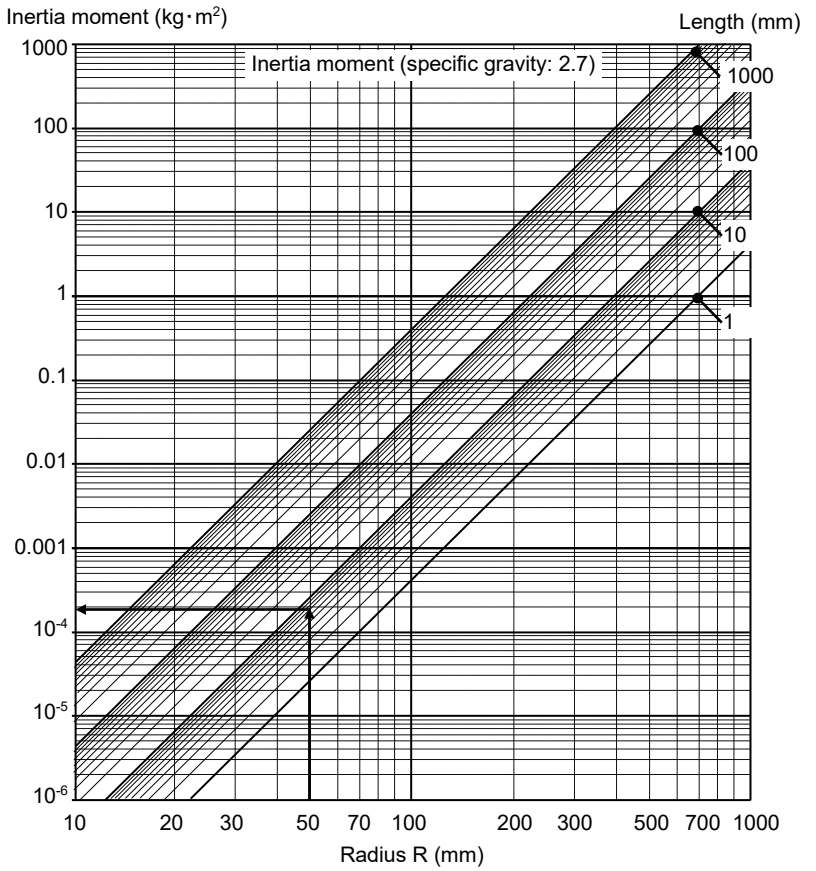

Sold & Serviced By:



Toll Free Phone (877) SERV098

Toll Free Fax (877) SERV099

[www.electromate.com](http://www.electromate.com)

[sales@electromate.com](mailto:sales@electromate.com)



# Index

---

## **A**

Acceleration time .....	2-10
Allowable load inertia moment.....	2-1
Average rotation speed.....	2-11

## **C**

Cable length 5 m .....	4-10
Cable specifications.....	1-23
Cable taken out from rear face .....	4-11
Combinations with drivers .....	1-3
Conformance to overseas standards.....	7

## **D**

Deceleration time.....	2-10
------------------------	------

## **E**

Effective torque.....	2-11
Encoder cable specifications .....	1-23
Environment of location .....	3-3
Examining actuator rotation speed .....	2-8
Examining operating status .....	2-8
Extension cables .....	4-17
External dimensions .....	1-8

## **I**

Inertia moment.....	5-3
Inertia moment of a cylinder .....	5-5
Installation .....	3-4

## **L**

Life.....	2-5
Load inertia moment.....	2-3, 2-8
Load torque .....	2-9
Load weight .....	2-4
Location and installation .....	3-3

## **M**

Maximum load weights .....	2-5
Mechanical accuracy .....	1-10
Model.....	1-2

Moment stiffness .....	1-13
Motor cable specifications .....	1-23
Motor shaft holding brake .....	4-7
Motor shaft holding brake cable specifications ....	4-8
Motor shaft holding brake specifications.....	4-7

## **N**

Notices on handling.....	3-2
--------------------------	-----

## **O**

Operable range .....	1-18
Outlines .....	1-1

## **R**

Receiving inspection.....	3-1
Related manual .....	7
Resistance to vibration .....	1-17
Resolution of output shaft.....	1-12
Revolution sensor.....	4-12
Revolution sensor specifications .....	4-12
Rigidity.....	1-13
Rotation direction .....	1-15

## **S**

Sensor adjustment method.....	4-13
Sensor drive range .....	4-14
Shock resistance .....	1-16
Specifications .....	1-4
Specifications for 100 VAC input power supply ...	4-1
Specifications for high accuracy .....	4-15
Static safety coefficient.....	2-7

## **T**

Torsional stiffness .....	1-14
---------------------------	------

## **U**

Uni-directional positional accuracy .....	1-11
Unit.....	5-1

## **W**

With connector .....	4-9
----------------------	-----



## Warranty Period and Terms

The equipment listed in this document is warranted as follows:

### ■ Warranty period

Under the condition that the actuators are handled, used and maintained properly followed each item of the documents and the manuals, all the applicable products are warranted against defects in workmanship and materials for the shorter period of either one year after delivery or 2,000 hours of operation time.

### ■ Warranty terms

All the applicable products are warranted against defects in workmanship and materials for the warranted period. This limited warranty does not apply to any product that has been subject to:

- (1) user's misapplication, improper installation, inadequate maintenance, or misuse.
- (2) disassembling, modification or repair by others than Harmonic Drive Systems, Inc.
- (3) imperfection caused by a non-applicable product.
- (4) disaster or others that does not belong to the responsibility of Harmonic Drive Systems, Inc.

Our liability shall be limited exclusively to repairing or replacing the product only found by Harmonic Drive Systems, Inc. to be defective. Harmonic Drive Systems, Inc. shall not be liable for consequential damages of other equipment caused by the defective products, and shall not be liable for the incidental and consequential expenses and the labor costs for detaching and installing to the driven equipment.

All efforts have been made to assure that the information in this catalog is complete and accurate. However, Harmonic Drive LLC is not liable for any errors, omissions or inaccuracies in the reported data. Harmonic Drive LLC reserves the right to change the product specifications, for any reason, without prior notice.

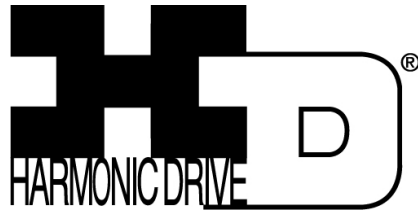

Registered Trademark in Japan

© 2019 Harmonic Drive. All rights reserved.  
All specifications and dimensions in this manual subject to change without notice.

[harmonicdrive.net](http://harmonicdrive.net)

**Harmonic Drive LLC**  
**Headquarters/Manufacturing**  
42 Dunham Ridge, Beverly, MA 01915

**New York Office**  
100 Motor Parkway Suite #116, Hauppauge, NY 11788

**Chicago Office**  
137 N. Oak Park Ave. Suite 410, Oak Park, IL 60301

**California Office**  
333 W. San Carlos St. Suite 1070, San Jose, CA 95110

TEL: 800.921.3332

**Group Companies**  
**Harmonic Drive Systems Inc**  
7F 6-25-3 Minami-Ohi, Shinagawa-ku, Tokyo, Japan 〒140-0013  
TEL+81(0)3-5471-7800 FAX+81(0)3-5471-7811

**Harmonic Drive SE**  
Hoenbergstraße 14, 65555 Limburg, Germany  
TEL06431-5008-0 FAX06431-5008-18