

DS-247-128

Absolute Position, Rotary Electric Encoder™



The **DS-247** is a member of the DS series of Electric Encoders, based on Netzer Precision proprietary technology. These encoders offer many advantages, some unparalleled:

- Low profile (18 mm).
- Hollow, floating shaft.
- No bearings or other contacting elements.
- High precision.
- High tolerance to temperature, shock, moisture, EMI, RFI and magnetic fields.
- Analog or multiple digital interface options.
- Extremely low power options.

The **DS-247** is suited to demanding application such as: aerospace, medical, instrumentation, automation, etc.

Mechanical	
Allowable mounting eccentricity ⁽²⁾	±0.2 mm
Allowable rotor axial motion ⁽²⁾	±0.1 mm
Rotor inertia	158.434 gr · mm ²
Total weight	665 gr
Outer diameter / Inner diameter / Profile	247 / 170 / 18 mm
Material (stator, rotor)	Aluminum, Ultem™

The holistic ⁽¹⁾ structure of the Electric Encoder™ provides generous mounting tolerance, thus obviating the need for internal ball bearings.

The lack of bearings and components such as flexible couplers, glass disc, light sources and detectors, along with very low power consumption makes the **DS-247** encoder virtually failure free.

The internally shielded, DC operated Electric Encoder™ includes an electric field generator, a field receiver, a sinusoidal shaped dielectric rotor, and processing electronics.

The output signals of Electric Encoder™ are analog Sine / Cosine representing the rotation angle. The digital outputs are obtained by further processing which may be either internal or external to the encoder.

Electrical - common to all types	
Supply voltage	5V ± 5% ⁽³⁾
Interconnection	6 pins connector + 250 mm Teflon-coated, loose AWG-32 wires
Environment	
EMC ⁽⁴⁾	IEC 6100-6-2, IEC 6100-6-4
Operating temperature range	-55°C to +125°C ⁽⁵⁾
Relative humidity	<98 % - non condensing
Shock endurance	IEC 60068-2-27 ; 100 g for 11 ms
Vibration endurance	IEC 60068-2-6 ; 20 g 10 – 2000 Hz
Protection ⁽⁶⁾	IP 40

Output options		
Analog	Digital	
Sine/Cosine	SSi	AqB + Index

Performance	
Electrical Cycles/Revolution – Fine/Coarse channels ⁽⁷⁾	128 / 7
Angular resolution (using 12 bit A/D conversion) ⁽⁸⁾	20 bits
Static error (with offset compensation) ⁽⁹⁾	< 10 mDeg
Maximum operational speed ⁽¹⁰⁾	375 rpm
Measurement range	Unlimited rotation

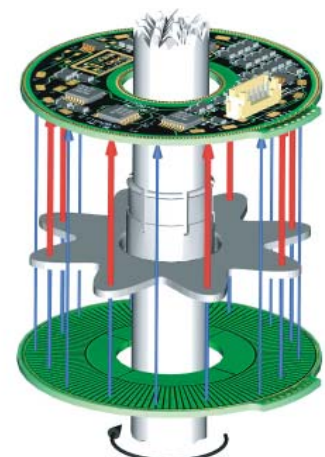

Digital - SSi Interface (absolute position)

DS-247-128-Dn-0

Full Time Phone: (877) 869-0998
 For Free Call: (877) 469-0999
 www.electromate.com
 sales@electromate.com

Output signal parameters	
Signal latency ⁽¹¹⁾	~250 µSec
Output code	Binary
Serial output SSi	Differential RS-422
Clock SSi	Differential RS-422
Monoflop time	25 µSec
Clock Frequency	0.5 ÷ 2.5 MHz
Maximum payload	21 bit

Electrical parameters	
Current consumption	~ 180 mA

The native output signals are analog Sine / Cosine of the rotation angle. The digital outputs are obtained by using external modules.

Synchronous Serial Interface (SSi) allows for serial transmission of absolute position data from the Electric Encoder™ responding to controller clock pulses. The Encoder and controller are linked by clock and data differential signal lines.

Figure 1 illustrates the SSi timing diagram used by the Electric Encoder™ which is implemented in the additional digital electronics which provides advanced calibration and monitoring options using the **NCP (Netzer Communication Protocol)** using factory supplied software tools.

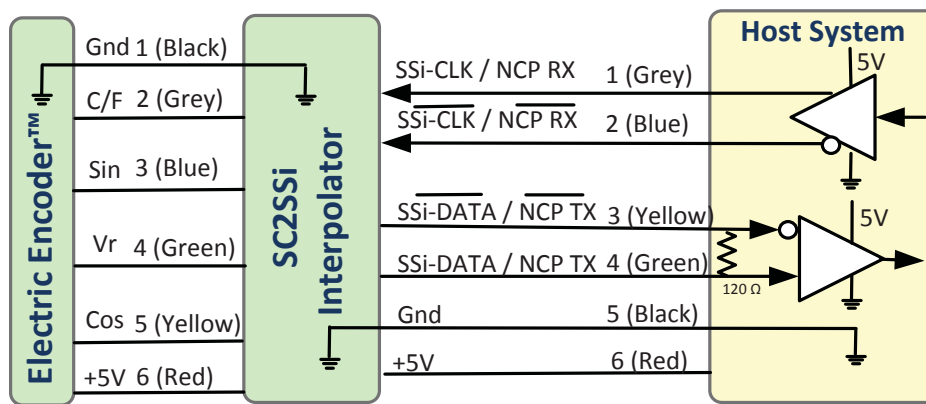

SC2SSi - Wires color code			
#	Name	Color	Function
1	Clock +	Grey	SSi Clock
2	Clock -	Blue	
3	Data -	Yellow	SSi Data
4	Data +	Green	
5	GND	Black	Ground
6	+5V	Red	Power supply

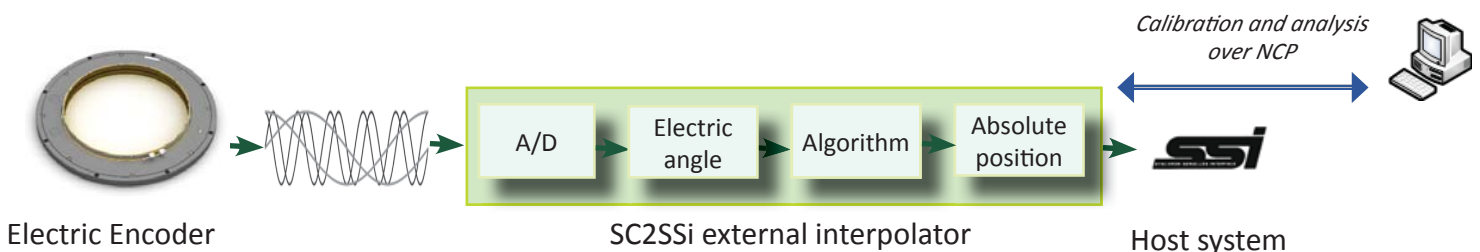

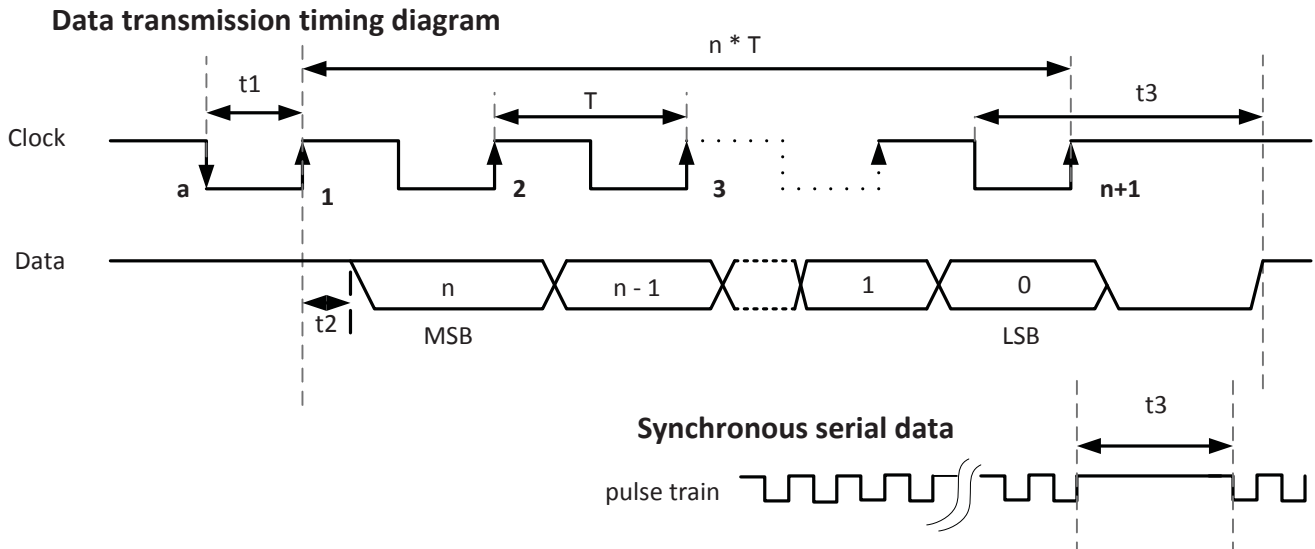

Figure - 1

- n = total number of data bits.
- T = clock period (sec) - user defined.
- $1/T$ = clock frequency $0.5 \div 2.5$ MHz (user defined).
- t_1 = minimum time required for the encoder to freeze data and preset the shift registers before receiving the first rising edge to prompt the MSB
- t_2 = data transmission delay (increases with cable length)
- t_3 = required delay to refresh position data between subsequent position reads.

Position calibration & signal analysis with SSi interface:

The Electric Encoder™ processing capabilities enable calibration, built-in tests (BIT) and advanced setup, using the available software tools, such as:

- A. Simple calibration procedure using the SSi Explorer (CAA , Offsets , Zero position setting).
- B. Field aid for validating proper mechanical mounting.

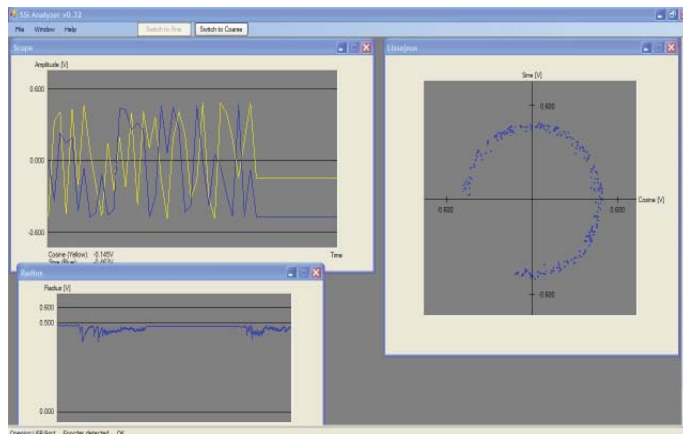
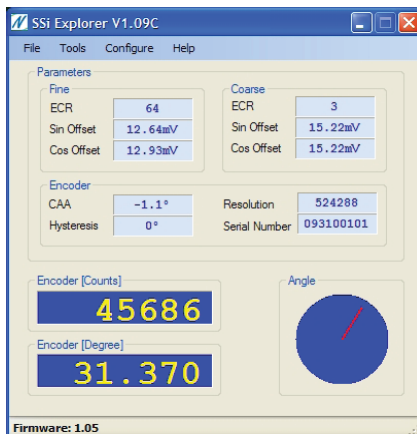

Digital - AqB + Index interface (incremental)

DS-247-128-Ch-0
 Tel: 02-2600-1077 SERV098
 Toll-Free Fax: (077) SERV099
 www.electromate.com
 sales@electromate.com

Output signal parameters	
Signal latency ⁽¹¹⁾	250 µSec
Format	Differential RS-422
Phase relationship with CW shaft rotation (as seen from top)	A leads B
Index pulse width	½ A

Electrical parameters	
Current consumption	~ 130 mA

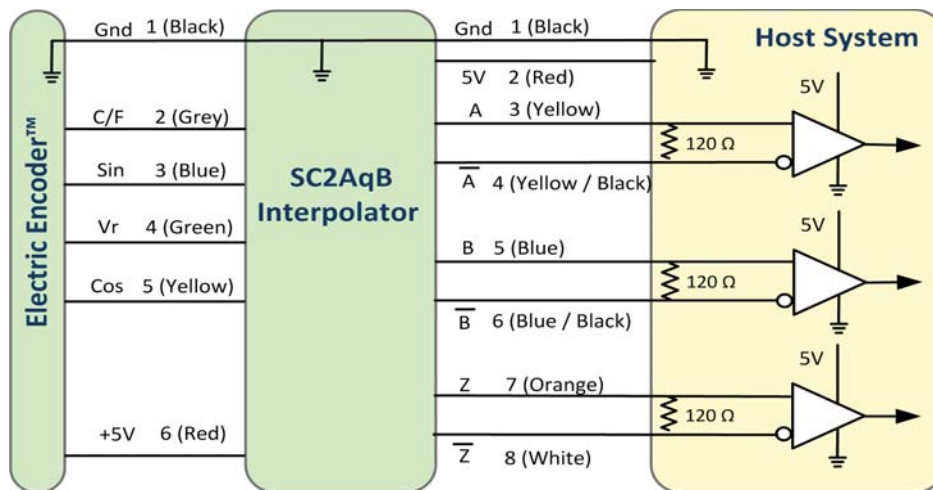
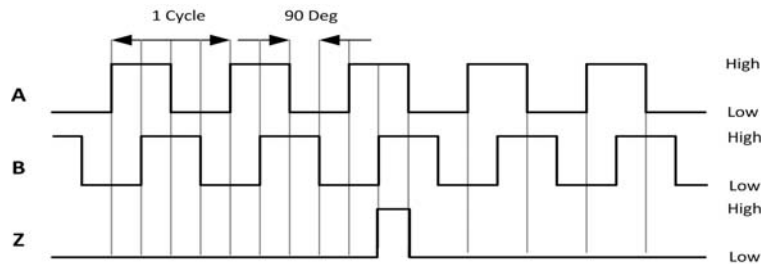

SC2AqB - Wires color code			
#	Name	Color	Function
1	GND	Black	Ground
2	+5V	Red	Supply voltage
3	A+	Yellow	Quadrature outputs
4	A-	Yellow/Black	
5	B+	Blue	
6	B-	Blue / Black	
7	Z+	Orange	Index
8	Z-	White	



Electric Encoder

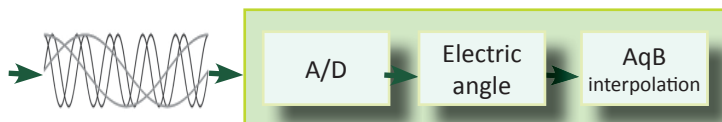

SC2AqB interpolator

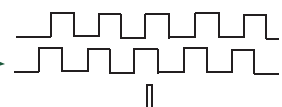

AqB + Index

Analog - Sine/Cosine output (absolute position)

DS-247-128-00-0

www.electromate.com
sales@electromate.com

Output signal parameters	
Signal latency ⁽¹¹⁾	400 μ Sec
Fine-mode output noise (DC to 1kHz) ⁽¹²⁾	200 μ V (p-p)
Fine-mode output amplitude ⁽¹³⁾	1V \pm 10%
Coarse-mode output amplitude	1V \pm 10%
Phase relationship (CW shaft rotation - seen from top)	Sine leads Cosine
Signal bandwidth	DC to 1 kHz

Electrical parameters	
Output resistance	<1 Ω
Current consumption	\sim 10 mA ⁽¹⁴⁾

Coarse and Fine channels

The DS-247 has two operational modes: a Coarse-mode and a Fine-mode - equivalent to two separate encoders in a common housing. The modes are selectable by a logic C/F command; logic "0" (0V to +0.5V) selects the Coarse-mode, which has 7 Electrical Cycle/Revolution (EC/R) while logic "1" (+3V to +5V) selects the Fine-mode which has 128 EC/R. The switching time is less than 1 ms.

The Coarse-mode outputs need to be read only upon system initiation after which the encoder is permanently switched to the Fine mode. Coarse and Fine sine/cosine pairs are used to calculate the initial absolute position, from that point tracking the Fine-channel outputs provides the absolute mechanical rotation angle with the specified accuracy and resolution.

All output signals are referenced to an internally generated voltage Vr (~2.25V)

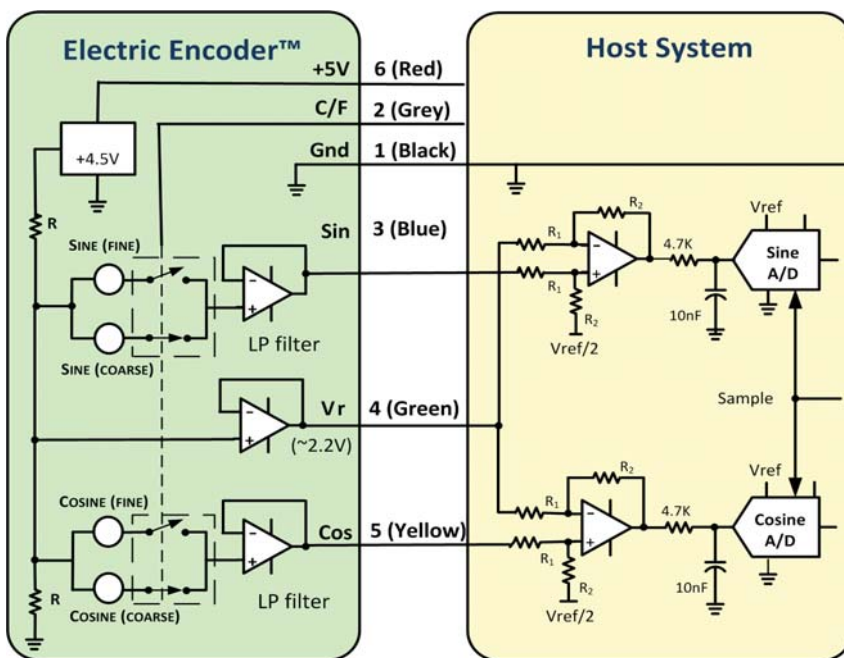

Wires color code			
#	Name	Color	Function
1	GND	Black	Ground
2	C/F	Grey	Coarse / Fine
3	Sine	Blue	Sine signal
4	Vr	Green	V reference
5	Cosine	Yellow	Cosine signal
6	+5V	Red	Power supply

Absolute Position calculation:

The analog Sine /Cosine outputs convey the electric angle of the Coarse or Fine signals. The absolute mechanical angle is computed by digitizing the analog signals and applying factory-supplied algorithms. Please refer to AN-02 and AN-03 .

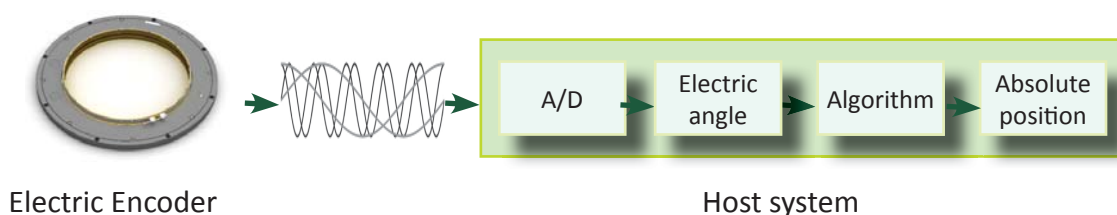

Notes

1. The output signals are generated by the whole area of the rotor - see AN-01.
2. Accuracy may degrade depending on mounting tolerances and the Sine/Cosine amplitudes may exceed the A/D conversion range -see AN-02
3. The encoder includes an internal 4.5V LDO voltage regulator.
4. Standard DS encoders are insensitive to ESD, stray magnetic and capacitive coupling from the host system current consumption. However it is advisable to allow a discharge path of no more than several tens of kΩ between the machine shaft and the electronic's ground, not leaving it electrically floating.
5. Consult factory.
6. For higher ingress protection the encoder should be mounted inside a sealed enclosure.
7. The number of electrical sine/cosine cycles generated in one mechanical rotation.
8. The angular resolution is determined by the ratio of the Fine - channel amplitude and the encoder inherent noise – see AN-05.
9. Not including dynamic error. For higher static accuracy consult factory.
10. Determined by the Fine-channel EC/Rs and the internal low pass filters, for higher rotation speed consult factory.
11. An inherent signal delay inversely proportional to the internal filter's cut-off frequency (1 kHz, 3rd order Bessel) and resulting in a dynamic error proportional to the rotation speed - see AN-05
12. For measuring the noise and validating the interconnection see AN-02.
13. With the rotor at its nominal axial position - see AN-02.
14. For a micro-power version with current consumption down to 50 μA @ 3V consult factory.

Resolution In bits	Steps /360°	mDeg /step	Arc-sec /step	mRad /step
17	131,072	2.7466	9.8877	0.0479
18	262,144	1.3733	4.9438	0.024
19	524,288	0.6866	2.4719	0.012
20 (DS-247)	1,048,576	0.3433	1.236	0.006
21	2,097,152	0.1717	0.618	0.003
22	4,194,304	0.0858	0.309	0.0015

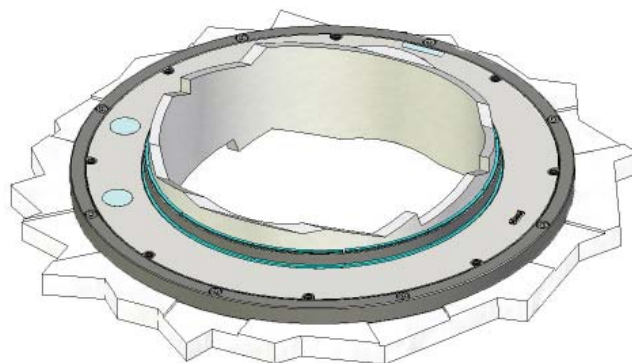

Related documents:

DS-247 Mechanical Installation Guide

Ordering

DS - 247- 128 - DI - C

DS
Product line

OD
EC/R

Connector

Outputs

0 - Analog: Sine/Cosine

C - Digital : AqB + index (external module SC2AqB)

D - Digital : SSi (external module SC2SSi03)

Binary									
Resolution CPR	4,096	8,192	16,384	32,768	65,536	131,072	262,144	524,288	1,048,576
Bit	12	13	14	15	16	17	18	19	20
Code	A	B	C	D	E	F	G	H	I

Decimal									
Resolution CPR		8,000	16,000	32,000	64,000	128,000	256,000	512,000	1,012,000
Bit		13	14	15	16	17	18	19	20
Code		K	L	M	N	O	P	Q	R

Analog Sin/Cosine

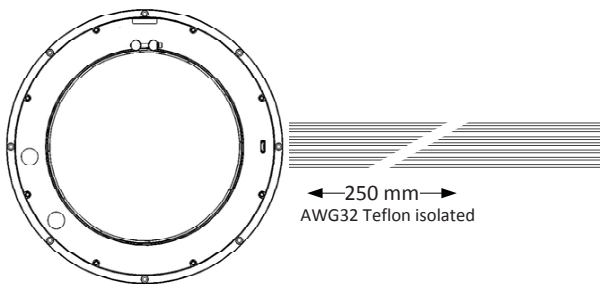

Digital SSi

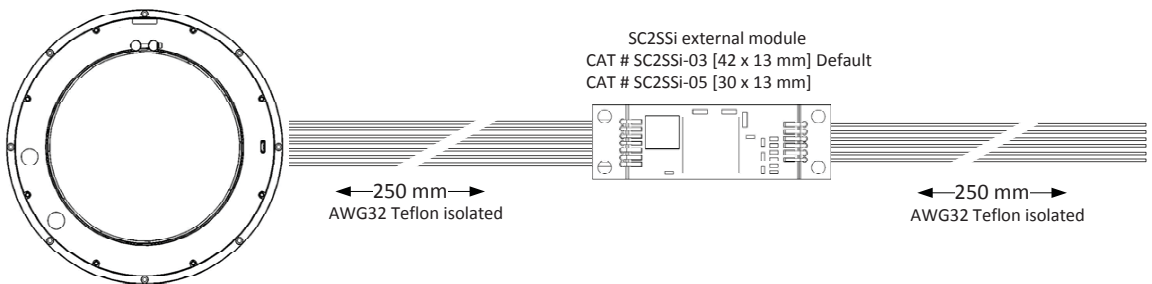

Digital AqB

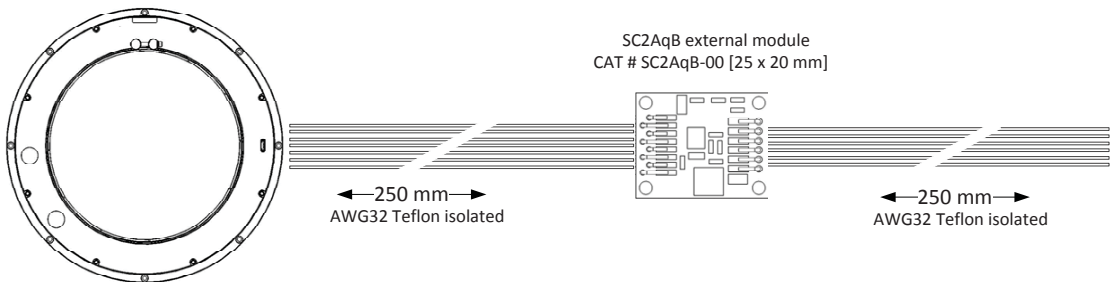

TOP VIEW

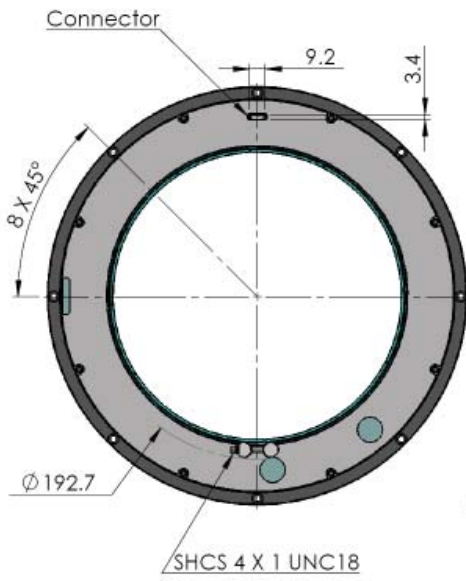

SECTION VIEW A-A
 (Scale 1 : 1)

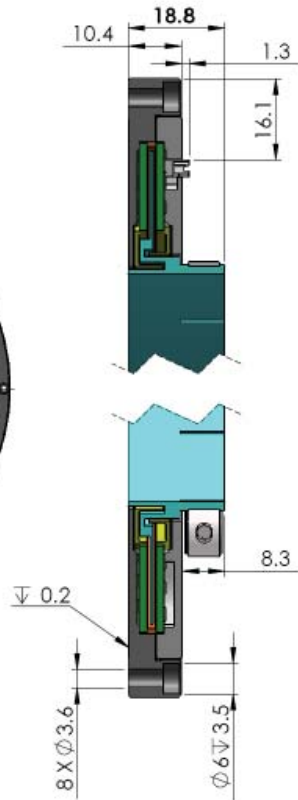

BOTTOM VIEW

