

FR 85-2 ILLG

Optical anti-collision sensor
for ems monorail systems

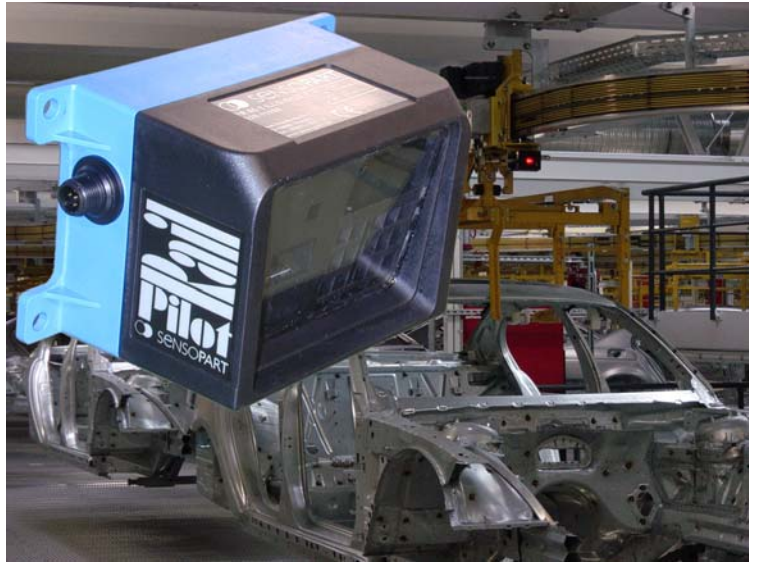

New perspectives for **collision protection**
on monorail carriers, by **time of flight technology**

Function

The sensor's task is to avoid a collision between monorail carriers (EMS carriers). The RailPilot fulfills this function reliably.

Depending on the transported goods and the vehicle speeds, the distances and the stop ways are different, therefore the RailPilot is equipped with flexible adjustable switching points.

Interferences such as reflections from surrounding shiny surfaces have no effect on the reliable function of the RailPilot.

- Scanning range 0 – 6000 mm
- Accuracy +/- 10cm
- 2x2 scanning areas
- 1 Input
- 2 PNP outputs
- RS 485 port
- Scanning range selectable externally
- Reliable suppression of surrounding reflections

Easiest setup via PC-Software

Technical Data FR 85-2 ILLG

Electrical Data	
Operating voltage	18...30 VDC
Operating voltage display	LED green
Power consumption	< 120mA @ 24V (without load)
Serial Port RS485	for FR 85-2 ILLG – SIL5
Short circuit and inverse polarity protection	Yes
Max. load per output Q1, Q2	200 mA
Output functions	Q1, Q2, PNP N.C. for FR 85-2 ILLG – POL5
Power-on delay	< 300ms
Protection	IP 54

Optical data	
Scanning range	0 – 6000 mm
Reference material	Reflector R 10/2
Typical accuracy	+/- 10cm
Measuring principle	Light time of flight measurement
Opening angle	horizontal +/- 7,5° vertical +/- 3,5 °
External light limit	Halogen light 5000 Lux
Type of light	IR 905nm

Mechanical data	
Housing	ABS
Shock resistance	EN 60947-5-2
Ambient temperature range	-10...+50°C
Storage temperature range	-20...+70°C
Connection	M12 plug
max. cable length	Q1, Q2<100m; RS 485<10m
Weight	approx. 340g

Dimensional Drawings

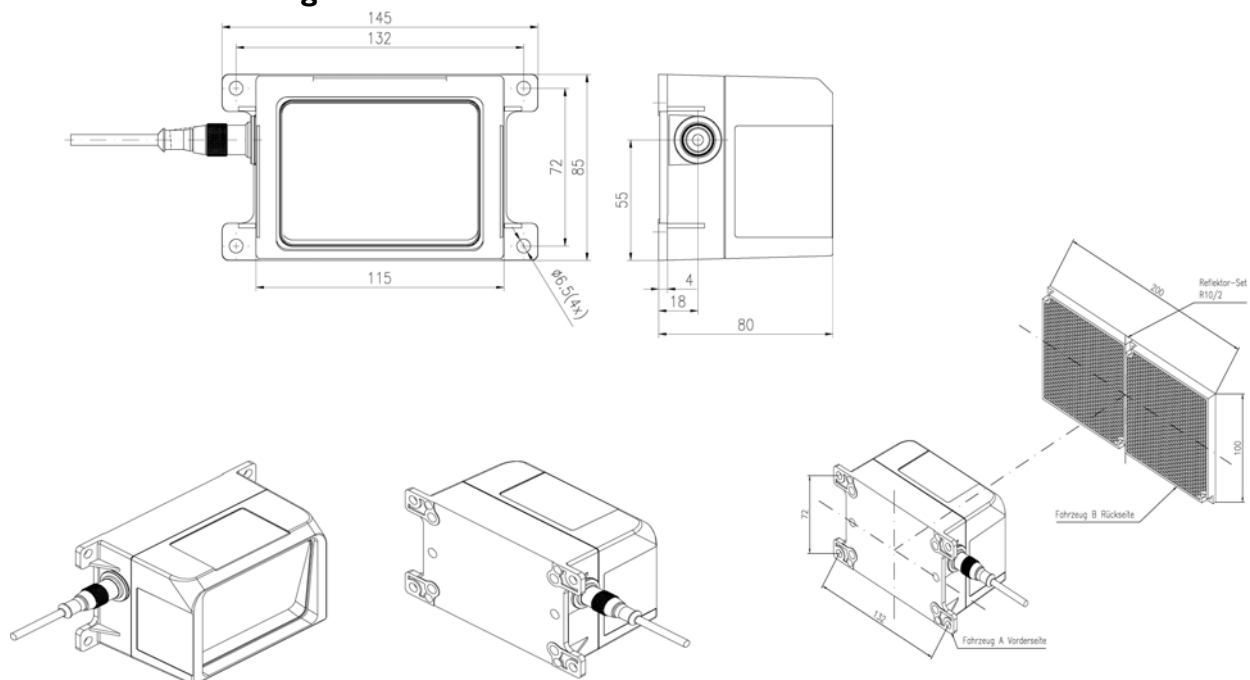

Sold & Serviced By:



Canadian and International Sales

ELECTROMATE

877-737-8698

sales@electromate.com

www.electromate.com

U.S. Sales

SERVO2GO.com

877-378-0240

sales@servo2go.com

www.servo2go.com