

FMS 18-34 U

Photoelectric proximity sensor for adaptation of fibre-optic cables



PRODUCT HIGHLIGHTS

- Scanning distance dependant on fibre-optic cable
- Fibre-optic cable adaptable
- Universal PNP/NPN output
- N.O./N.C. selectable
- M18 metal threaded sleeve

Optical data		Functions	
Scanning distance	See Selection Table ¹	Indicator LED, green	Operating voltage indicator
Type of light	See Selection Table	Indicator LED, yellow	Switching output indicator
Distance hysteresis ¹	< 10 % of the set scanning distance	Indicator LED, red	Contamination indicator
		Sensitivity adjustment	Via 18-step potentiometer
Electrical data		Mechanical data	
Operating voltage, +U _B	10 ... 30V DC ² / 15 ... 30V DC ³	Dimensions	See dimensional drawings
No-load current, I ₀	≤ 25 mA	Enclosure rating	IP 65 ⁵
Output current, I _e	≤ 200 mA	Material, housing	Brass, nickel-plated
Pull-up resistance	22 kΩ	Type of connection	See Selection Table
Pull-down resistance	22 kΩ	Ambient temperature: operation	-20 ... +60 °C
Protective circuits	Reverse-polarity protection, U _B / short-circuit protection (Q)	Ambient temperature: storage	-40 ... +80 °C
Protection Class	2	Weight (plug device)	85 g
Power On Delay	≤ 300 ms	Weight (cable device)	185 g
Switching output, Q	PNP/NPN	Vibration and impact resistance	EN 60947-5-2
Output function	N.O./N.C.		
Switching frequency, f (ti/tp 1:1)	See Selection Table ⁴		

¹ Reference material: white, 90 % reflectivity ² Type of light: infrared 880 nm ³ 10 % ripple, within U_B ⁴ Type of light: infrared 880 nm with scanning distance of 1 m

⁵ With connected IP 65 plug

Scanning distance	Type of light	Switching frequency, f (ti/tp 1:1)	Type of connection	Part number	Article number
500 mm	Infrared, 880 nm	5000 Hz	Plug, M12, 4-pin	FMS 18-34 UL4-60	510-51590
1000 mm	Infrared, 880 nm	1000 Hz	Plug, M12, 4-pin	FMS 18-34 UL4	510-51589
500 mm	Infrared, 880 nm	5000 Hz	Cable, 3 m, 4-wire	FMS 18-34 U-60	510-51588
1000 mm	Infrared, 880 nm	1000 Hz	Cable, 3 m, 4-wire	FMS 18-34 U	510-51587
250 mm	Red, 645 nm	1000 Hz	Plug, M12, 4-pin	FMS 18-34 UL4-52	510-51602
500 mm	Infrared, 950 nm	1000 Hz	Plug, M12, 4-pin	FMS 18-34 UL4-54	510-51605
250 mm	Red, 645 nm	1000 Hz	Cable, 3 m, 4-wire	FMS 18-34 U-52	510-51603
500 mm	Infrared, 950 nm	1000 Hz	Cable, 3 m, 4-wire	FMS 18-34 U-54	510-51604

Sold & Serviced By:



Toll Free Phone (877) SERV098

www.electromate.com

sales@electromate.com

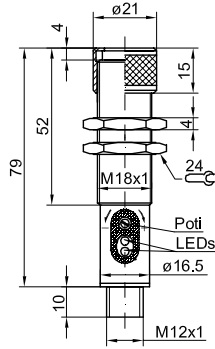
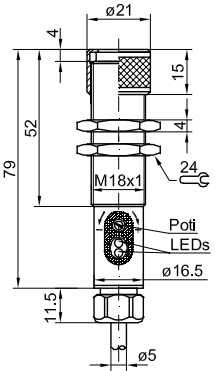
Plug connection	Cable connection
 <p style="text-align: right;">153-00002</p>	 <p style="text-align: right;">153-00001</p>

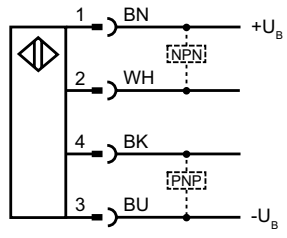
Connection, 4-pin	
 <p style="text-align: right;">154-00282</p>	

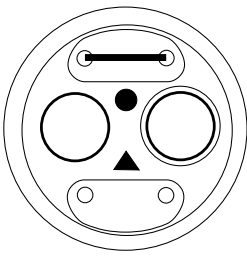
N.O./N.C. function			
Selectable via plug-in bridge on the front	Plug-in bridge	Scanner operation	Through-beam operation
 <p style="text-align: right;">155-00921</p>	●	N.C.	N.O.
	Without plug-in bridge	N.O.	N.C.
	▲	Parking position	Parking position

Sold & Serviced By:

 Toll Free Phone (877) SERV098
www.electromate.com
sales@electromate.com