

FT 25-RL

Diffuse laser sensor

Sold & Serviced By:

ELECTROMATE

Toll Free Phone (877) SERV098

www.electromate.com

sales@electromate.com

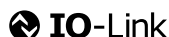

PRODUCT HIGHLIGHTS

- Differentiates between even the slightest of grey value differences
- Sensor settings via teach-in and control input
- Durable laser printing
- Very small, easily visible laser light spot
- Wide range of variants

Optical data		Functions	
Scanning distance	1 ... 250 mm ¹	Indicator LED, green	Operating voltage indicator
Adjustment range	25 ... 250 mm ¹	Indicator LED, yellow	Switching output indicator
Type of light	Laser, red, 650 nm	Sensitivity adjustment	Via Teach-in button, control input and IO-Link
Light spot size	See diagram	Teach-in modes	Mode 1: during running process Mode 2: during standing process
Laser Class (IEC 60825-1)	1	Adjustment possibilities	N.O./N.C. and Auto-Detect / NPN / PNP via teach-in button, control input and IO-Link Button lock via control input and IO-Link Wide variety of adjustment possibilities via IO-Link
Hysteresis	≤ 10 % ²	Default settings	Max. scanning distance and N.O.
Electrical data		Mechanical data	
Operating voltage, +U _B	10 ... 30V DC ³	Dimensions	34 x 20 x 12 mm
No-load current, I ₀	≤ 30 mA	Enclosure rating	IP 69 & IP 67 ⁵
Output current, I _e	≤ 100 mA	Material, housing	ABS
Protective circuits	Reverse-polarity protection, U _B / short-circuit protection (Q)	Material, front screen	PMMA
Protection Class	2	Type of connection	See selection table
Power On Delay	< 300 ms	Ambient temperature: operation	-20 ... +60 °C ⁶
Switching output, Q	1x Auto-Detect (PNP/NPN) ⁴	Ambient temperature: storage	-20 ... +80 °C
Output function	N.O./N.C.	Weight (metal plug device ⁷)	10 g
Switching frequency, f (ti/tp 1:1)	≤ 4000 Hz	Weight (cable device)	40 g
Response time	125 μs	Weight (pigtail)	20 g
Control input, IN	+U _B = teach-in -U _B = button locked Open = normal operation	Vibration and impact resistance	EN 60947-5-2
IO-Link			
Communication mode	COM 2		
Min. cycletime	2.3 ms		
SIO mode	Compatible		
Length process data	16 Bit		
Specification	1.1		

¹ Reference material: white, 90 % reflectivity ² Up to scanning distance of 150 mm ³ Max. 10 % ripple, within U_B, ~ 50 Hz / 100 Hz ⁴ Auto-Detect, automatic PNP/NPN selection by the sensor, PNP or NPN fixed ⁵ With connected IP 67 / IP 69 plug ⁶ UL: -20 ... +50 °C ⁷ No Ecolab

Scanning distance	Switching output	Type of connection	Part number	Article number
1 ... 250 mm	Auto-Detect	Metal plug, M8x1, 4-pin, IO-Link	FT 25-RL-PNSL-M4M	609-21021
1 ... 250 mm	Auto-Detect	Cable, 2 m, 4-wire, IO-Link	FT 25-RL-PNSL-K4	609-21019
1 ... 250 mm	Auto-Detect	Pigtail, 152 mm with plug, M8, 4-pin, IO-Link	FT 25-RL-PNSL-KM4	609-21018
1 ... 250 mm	Auto-Detect	Pigtail, 150 mm with plug, M12, 4-pin, IO-Link	FT 25-RL-PNSL-KL4	609-21020

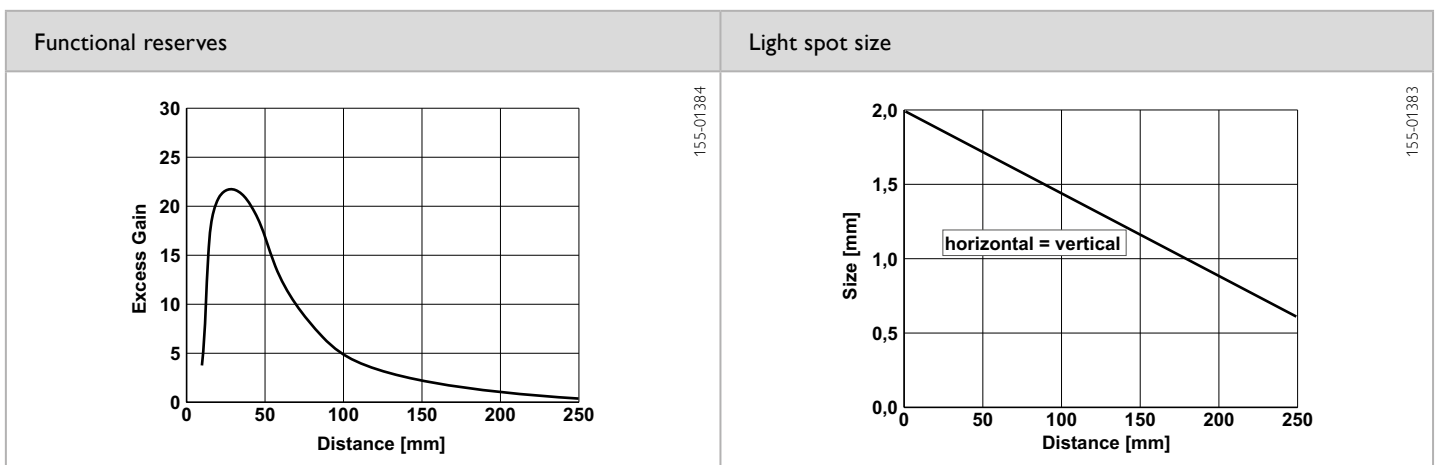
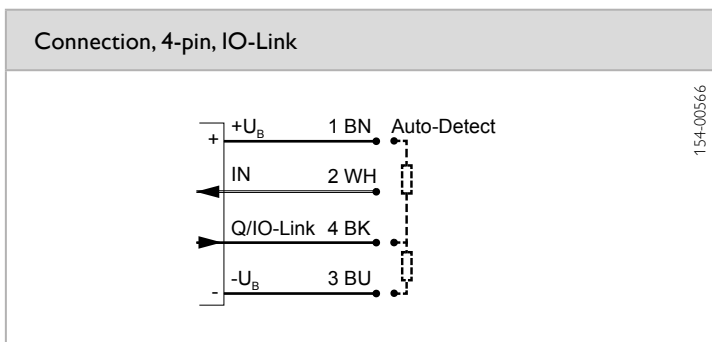
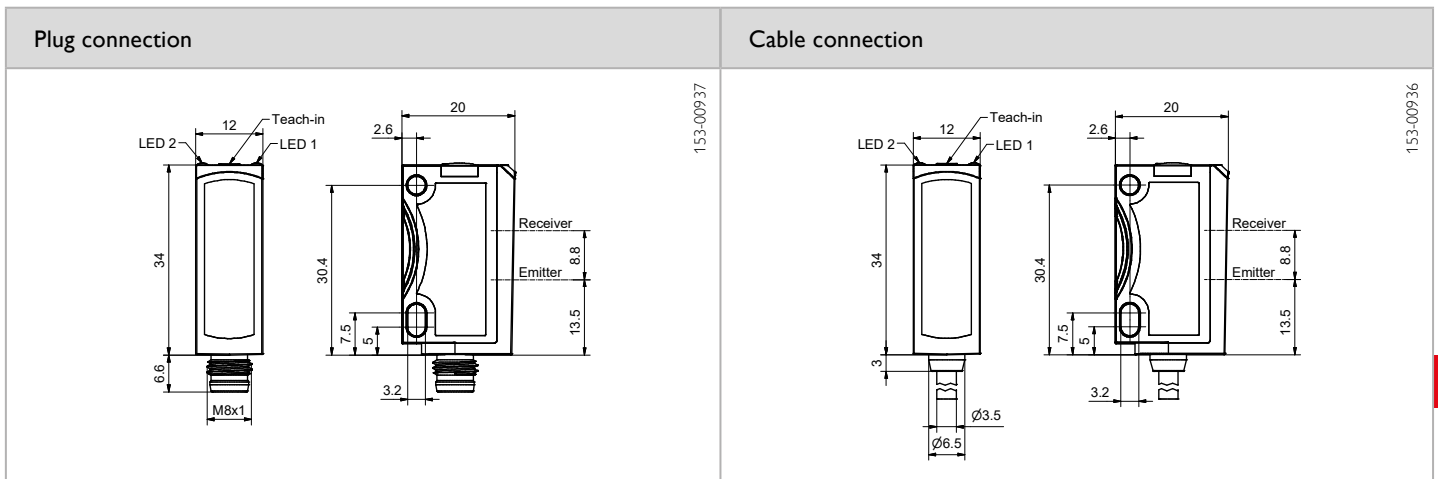

Reference material	Detection range	Accessories
White (90 %)	1 ... 250 mm	Connection cables
Grey (18 %)	6 ... 100 mm	Brackets
Black (6 %)	20 ... 60 mm	SensolO (901-01001)
		From Page A-38
		From Page A-4
		From Page A-56