

# FT 55-RLHM-1000

Diffuse laser sensor with background suppression

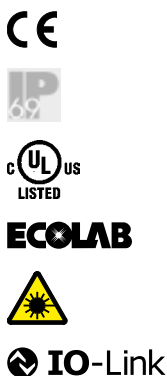

## PRODUCT HIGHLIGHTS

- Switching hysteresis of 2 enables smart part detection even at large distances up to 1000 mm
- Display for a higher level of user-comfort and a fast and easy setup of the sensor
- Most stable presence check thanks to intelligent evaluation algorithm

Optical data		Functions	
Scanning distance	200 ... 1000 mm / 0 ... 1000 mm <sup>1</sup>	Indicator LED 1, green	Operating voltage indicator
Hysteresis <sup>2</sup>	2 mm (adjustable)	Indicator LED 2, yellow	Status indicator Q <sub>1</sub> / Q <sub>2</sub>
Type of light	Laser, red 655 nm	Measurement range adjustment	Via display or IO-Link
Immunity to ambient light	≤ 20,000 lux	Adjustment possibilities	Teach-in Q <sub>1</sub> , Q <sub>2</sub> , Q as switching window or switching point; Setting of mean value Auto-Detect / NPN / PNP / Push-Pull Smart Functions (On-delay and drop-out delay, counter, impulse, frequency)
Light spot size (w x h)	4 x 1 mm		
Laser class (IEC 60825-1)	1		
Electrical data		Mechanical data	
Operating voltage +U <sub>b</sub>	15 ... 30V DC	Dimensions	50 x 50,5 x 25 mm
No-load current I <sub>0</sub>	≤ 50 mA	Enclosure rating	IP 67 & IP 69 <sup>4</sup>
Power consumption	≤ 1.5 W	Material, housing	Zinc die-cast, matt chrome
Output current I <sub>e</sub> Q	≤ 50 mA	Material, front screen / Display	PMMA
Protection circuits	Reverse polarity protection U <sub>b</sub> / short-circuit protection (Q)	Type of connection	Plug, M12x1, 5-pin
Protection class	2	Ambient temperature: operation	-20 ... +50 °C <sup>5</sup>
Power On Delay	< 300 ms	Ambient temperature: storage	-20 ... +60 °C
Switching output Q	Auto-Detect <sup>3</sup> / PNP / NPN / Push-Pull	Weight (plug device)	185 g
Output function	N.O./N.C.	Resistance to vibration and impacts	EN 60947-5-2
Switching frequency f (ti/tp 1:1) Q	≤ 1000 Hz (adjustable)	Display	LCD, with background illumination
Response time Q	600 μs		
Warm-up time	20 min.		
IO-Link			
Communication mode	COM 2		
Min. cycletime	3 ms		
SIO mode	Compatible		
Length process data	16 Bit		
Data Storage	compatible		
Specification	1.1		
Smart sensor profile	V 1.0		

Sold & Serviced By:



Toll Free Phone (877) SERV098  
[www.electromate.com](http://www.electromate.com)  
[sales@electromate.com](mailto:sales@electromate.com)

<sup>1</sup> In Detect All mode    <sup>2</sup> 5 ... 90 %; homogenous object, not moving    <sup>3</sup> Auto-Detect: Automatic selection of PNP or NPN by the sensor; PNP or NPN can be fixed

<sup>4</sup> With connected IP 67 / IP 69 plug    <sup>5</sup> UL: max. +45 °C

Scanning distance	Switching output	Type of connection	Part Number	Article number
200 ... 1000 m	Auto-Detect	Plug, M12x1, 5-pin, IO-Link	FT 55-RLHM-1000-2PNSDL-L5M	623-11043

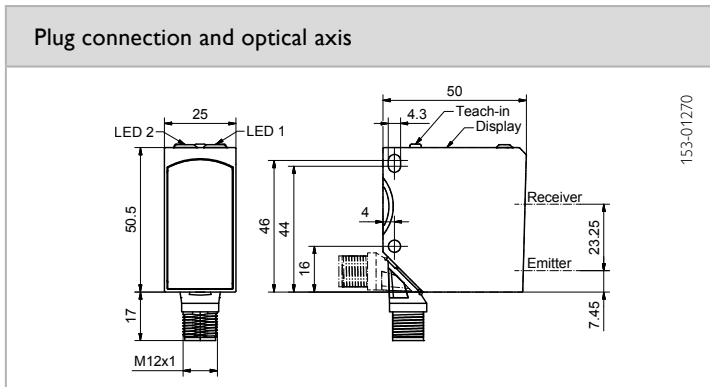

Sold & Serviced By:



Toll Free Phone (877) SERV098  
[www.electromate.com](http://www.electromate.com)  
[sales@electromate.com](mailto:sales@electromate.com)

7

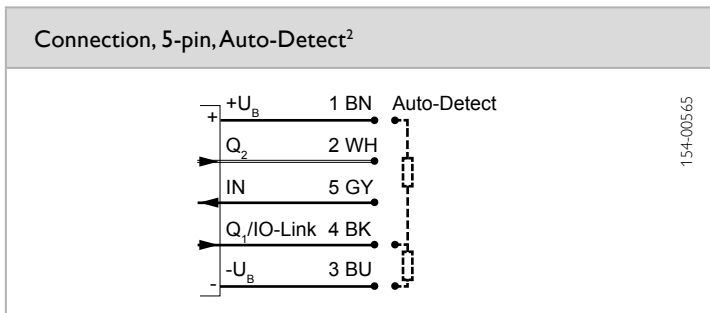

<sup>2</sup> In IO-Link mode, a 4-pin cable must be used

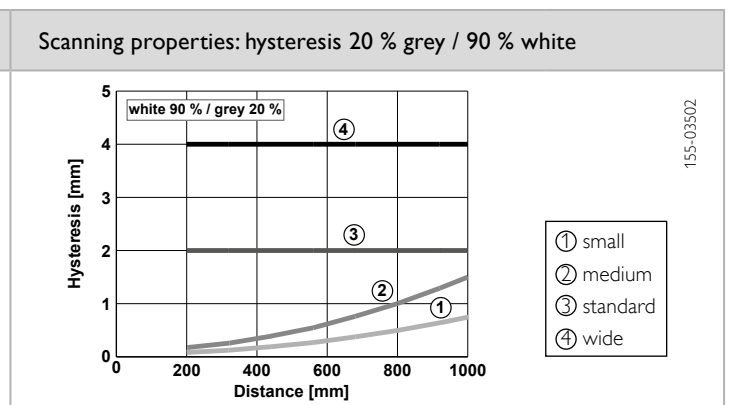
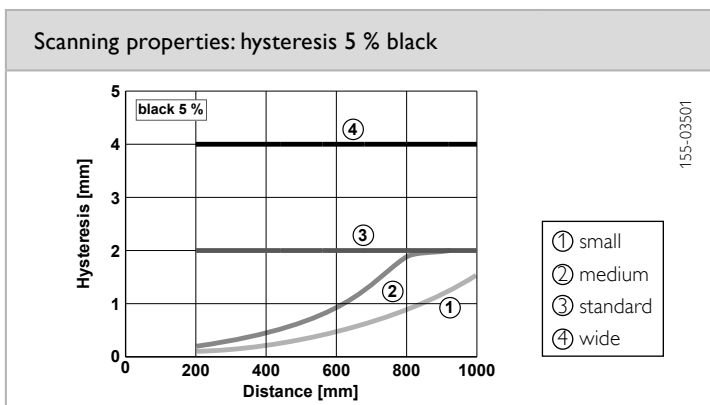

Reference material	Detection range
White (90 %)	200 ... 1000 mm
Grey (20 %)	200 ... 1000 mm
Black (5 %)	200 ... 1000 mm

Default setting	Accessories
Switching output Q <sub>1</sub>	1000 mm, N.O.
Switching output Q <sub>2</sub>	1000 mm, N.O.
	Connection cable M12 4-pin to M12 4-pin for SensoLO (L4/L4-2m-PUR / 902-51873) <sup>†</sup> Further connection cables Bracket SensoClip MBD F 55ST2 (579-50012) SensoLO (901-01000)
	From Page A-46
	From Page A-46
	From Page A-4
	From Page A-4