

# FT 92 IL

Diffuse infrared laser sensor with background suppression

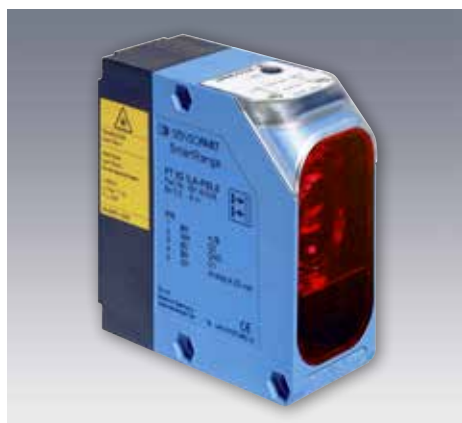

## PRODUCT HIGHLIGHTS

- Long range of 6 m
- Precise background suppression through time-of-flight technology
- Reliable operation even with highly reflective and glossy backgrounds
- Simple alignment via integrated pilot laser

| Optical data                                 |  | Functions                       |  |
|--|--|---------------------------------|--|
| Scanning distance                            | 0.2 ... 6 m <sup>1</sup>   | Indicator LED, green            | Operating voltage indicator              |
| Type of light, measurement laser             | Infrared, 905 nm   | Indicator LED, yellow           | Switching output indicator               |
| Laser Class, measurement laser (IEC 60825-1) | 1  | Indicator LED, orange           | Operating mode indicator (Fast / Slow)   |
| Type of light, pilot laser                   | Laser, red, 650 nm   | Scanning distance adjustment    | Via Teach-in button                      |
| Laser Class, pilot laser (IEC 60825-1)       | 1  | Adjustment possibilities        | Switching point set via Teach-in button  |
| Repeatability, Fast / Slow                   | ≤ ± 15 mm / 10 mm  | Default settings                | Switching window set via Teach-in button |
|  |  |                                 | Slow / Fast mode via Teach-in button     |
|  |  |                                 | N.O./N.C. via Teach-in button            |
|  |  |                                 | Pilot laser via Teach-in button          |
|  |  |                                 | Sn = 5.8 m and N.O.                      |
| Electrical data                              |  | Mechanical data                 |  |
| Operating voltage, +U <sub>B</sub>           | 18 ... 30V DC <sup>2</sup>   | Dimensions                      | 95 x 93 x 42 mm                          |
| No-load current, I <sub>0</sub>              | ≤ 125 mA   | Enclosure rating                | IP 67 <sup>3</sup>                       |
| Output current, I <sub>e</sub>               | 100 mA   | Material, housing               | ABS                                      |
| Voltage drop, U <sub>D</sub>                 | ≤ 2.4 V  | Material, front screen          | PMMA                                     |
| Protective circuits                          | Reverse-polarity protection, U <sub>B</sub> / short-circuit protection (Q) | Type of connection              | See selection table                      |
| Protection Class                             | 2  | Ambient temperature: operation  | -20 ... +50 °C                           |
| Power On Delay                               | < 300 ms   | Ambient temperature: storage    | -40 ... +80 °C                           |
| Switching output, Q                          | PNP/NPN (see selection table)  | Weight                          | 200 g                                    |
| Output function                              | N.O./N.C.  | Vibration and impact resistance | EN 60947-5-2                             |
| Response time, Fast / Slow                   | 13 / 80 ms   |                                 |  |

<sup>1</sup> Reference material, white, 90 % reflectivity    <sup>2</sup> Max. 10 % ripple, within U<sub>B</sub>    <sup>3</sup> With connected IP 67 plug

| Scanning distance | Switching output | Type of connection | Part number   | Article number |
|-------------------|------------------|--------------------|---------------|----------------|
| 0.2 ... 6 m       | PNP              | Plug, M12x1, 4-pin | FT 92 IL-PSL4 | 591-91007      |
| 0.2 ... 6 m       | NPN              | Plug, M12x1, 4-pin | FT 92 IL-NSL4 | 591-91009      |

| Accessories       |                |
|-------------------|----------------|
| Connection cables | From Page A-38 |
| Brackets          | From Page A-4  |

Sold & Serviced By:

 **ELECTROMATE**

Toll Free Phone (877) SERV098

[www.electromate.com](http://www.electromate.com)

[sales@electromate.com](mailto:sales@electromate.com)

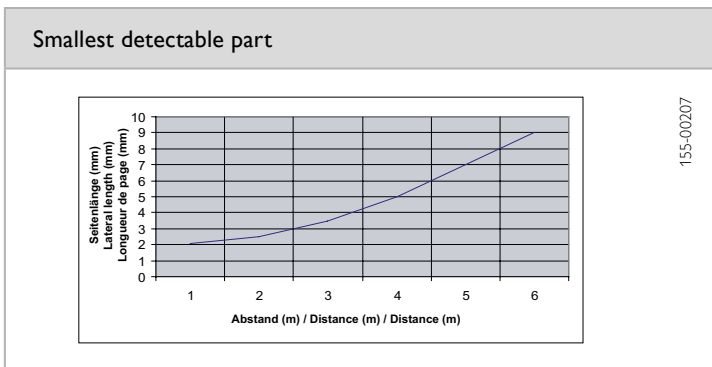
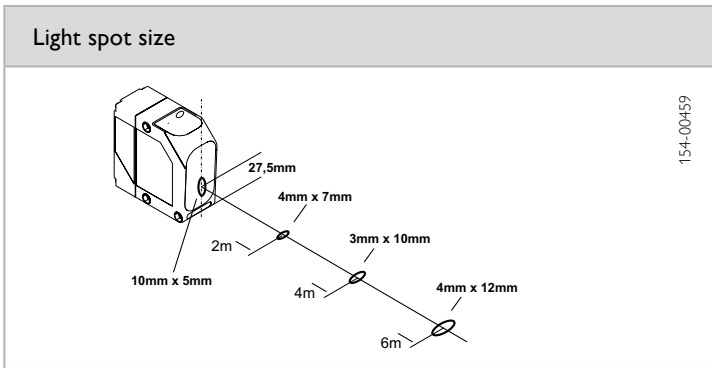
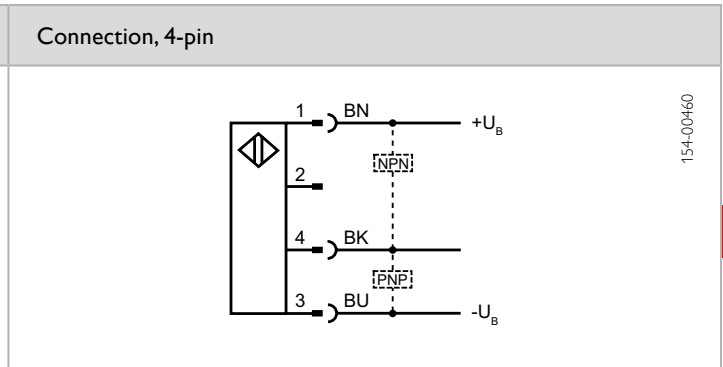
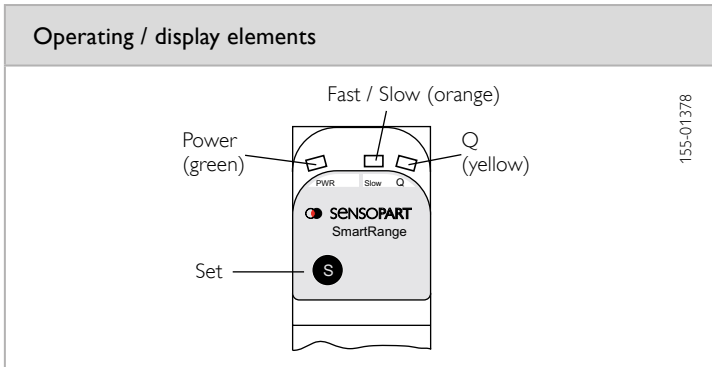
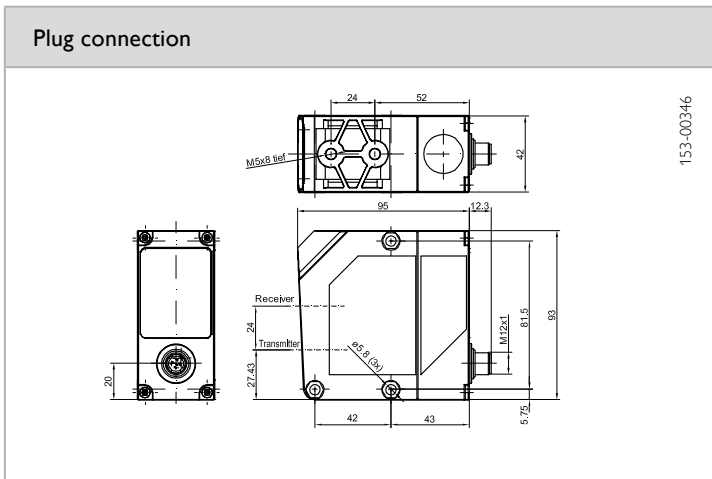

| Reference material | Detection range |
|--------------------|-----------------|
| White (90 %)       | 0.2 ... 6 m     |
| Grey (18 %)        | 0.2 ... 6 m     |
| Black (6 %)        | 0.2 ... 2.5 m   |

Sold & Serviced By:  
**ELECTROMATE**  
 Toll Free Phone (877) SERV098  
[www.electromate.com](http://www.electromate.com)  
[sales@electromate.com](mailto:sales@electromate.com)