

VISOR® V50 Allround Professional, C-mount

Combines VISOR® Object Color, Code Reader and Robotic



PRODUCT HIGHLIGHTS

- All evaluations ("Detectors") of object sensor and code reader united in one device
- Highly accurate evaluation via 5 megapixel chip
- Real-world engineering units and robot coordinates at a mouse click
- Precise position determination: X/Y-position and orientation
- Detection of differences in height in the pseudo height image with multishot technology
- User-friendly configuration and viewer software with graded user rights and online help

Optical data		Functions	
Resolution	2560 x 1936 pixels	Number of jobs / detectors	Max. 255 / max. 255
Imaging chip CMOS	1/1.8", monochrome / color	Detectors	Position tracking; X/Y and orientation; Pattern matching, contour, 3D contour: teach-in and detection of patterns and contours; Calliper: distance between edges; BLOB, grey threshold, brightness: evaluation of brightness; Contrast: evaluation of contrast; Color value¹: output of color values; Color area¹: area inspection of colors, with selectable tolerance; Color list¹: finding the most similar colors; Barcode: reading 1D barcodes; EAN, UPC, RSS, 2/5 Interleaved, 2/5 Industrial, code 32, code 39, code 93, code 128, ECC200 GS1, pharm code, codabar; Datacode: reading 2D codes; ECC200, QR code, PDF 417, ECC200 GS1; OCR: reading of fonts; Result processing: Text, Math: checking and calculating with results from detectors
Integrated lens, focal length [mm]	C-mount		
Pixel size	2.8 µm x 2.8 µm		
Focus	Manual		
Adjustment range	Dependent on lens		
Integrated illumination	None		
Minimum field of view, X x Y	Dependent on lens		
Target laser	No		
Electrical data		Mechanical data	
Operating voltage, +U _B	18 ... 30V DC ²	Dimensions	70.4 x 45 x 45 mm (without plug)
Current consumption (without I/O)	≤ 300 mA	Enclosure rating	IP 67 & IP 65 ³
Protective circuits	Reverse-polarity protection, U _B / short-circuit protection of all outputs	Material, housing	Aluminium, die-cast, RoHS compliant
Power On Delay	Approx. 13 s after Power on	Material, front screen	Plastic
Outputs	PNP/NPN (switchable)	Ambient temperature: operation	0 ... +50 °C ⁴
Max. output current (per output)	50 mA, 100 mA (pin 12)	Ambient temperature: storage	-20 ... +60 °C ⁴
Switching threshold inputs incl. encoder	PNP/NPN High > U _B -1V / Low < 3V	Weight	Approx. 200 g
Input resistance	> 20 kΩ	Plug connections	Supply and I/O M12, 12-pin Ethernet M12, 4-pin
Interfaces	Ethernet (LAN), EtherNet/IP, PROFINET, SensoWeb, Service Port	Vibrationsfestigkeit	EN 60068-2-6
Inputs/outputs	2 inputs, 2 outputs, 6 selectable inputs/outputs	Schockfestigkeit	EN 60068-2-27
Encoder	✓		

¹ Color hardware ² Max. ripple < 5V_{SS} ³ Only with protective casing ⁴ 80 % air humidity, noncondensing

VISOR® vision sensor C-mount

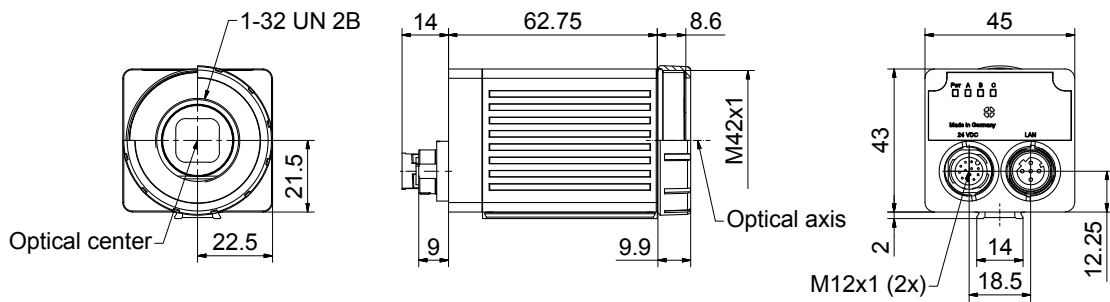

153-13555

3

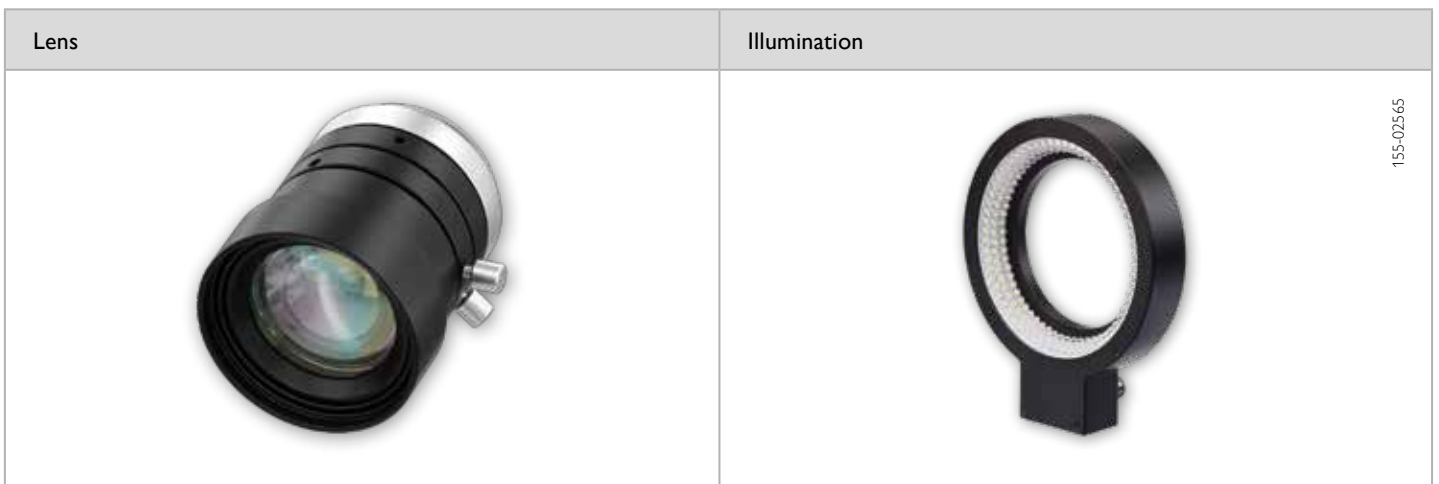

155-02565

Sold & Serviced By:



Toll Free Phone (877) SERV098
 www.electromate.com
 sales@electromate.com

Illumination	Part number	Article number
White	LM 100 WWK-24Q4-2L12	532-51096
Red	LM 100 RWK-24Q4-2L12	532-51097
-	LM 100 W DF	532-51098

	LOC-08-HD-30.5x0.5	LOC-12-HD-27x0.5	LOC-16-HD-27x0.5	LOC-25-HD-27x0.5	LOC-35-HD-27x0.5	LOC-50-HD-27x0.5	LOC-75-HD-34x0.5
Focal length	8 mm	12 mm	16 mm	25 mm	35 mm	50 mm	75 mm
Article number	526-51535	526-51536	526-51537	526-51538	526-51539	526-51540	526-51541

Part number	Article number	Accessories
V50-ALL-P3-C-2	635-91006	Connection cables
V50C-ALL-P3-C-2	635-91009	Illumination
		Lenses
		Brackets
		Interface accessories

www.sensopart.com/en/accessories