

Sold & Serviced By:



Toll Free Phone (877) SERV098

Toll Free Fax (877) SERV099

www.electromate.com

sales@electromate.com



Linear Motion. Optimized.

Debunking the Myths of Hydraulic to Electric Actuator Conversion

With rugged and reliable operation, simple installation, and lower costs, electric actuators are paving the way for significant control and productivity improvements in off highway machinery.

Many manufacturers of off-highway equipment have replaced hydraulic cylinders with electric actuators in order to eliminate pumps, hoses and valves, and make vehicles smaller, lighter and quieter. They have taken advantage of the flexibility in interfacing with control systems to provide a wide range of new features and capabilities. For example, electric actuators can easily interface with a vehicle controller for complex motions such as cycling for a specified number of times at various positions, resulting in improved off highway machine performance and productivity.

Today the benefits of electric actuators can be realized in applications with static loads up to 5000 lbs and dynamic loads up to 3000 lbs., with load ratings increasing each year. For now, hydraulic cylinders are required for higher loads or when moving loads at 100% duty cycle.

But certain myths have arisen about electric linear actuators that have slowed their adoption in many applications where they potentially offer substantial OEM and end-user advantages. The rest of this article will take a close look at these myths and discuss the opportunities for integrating electric linear actuators in off-highway vehicles and machinery including recreational vehicles, sprayer booms, snow blowers, turf, garden, construction and agricultural equipment.

Myth #1: Electric actuators can't handle a harsh environment

Hydraulic technology has been used in off-road vehicles for many decades and engineers have become familiar with its ruggedness in environments with high levels of shock, vibration, dust, water, corrosive chemicals, and other potential hazards. Hydraulic actuators have also historically enjoyed a lead in power density over their electric counterparts, which enhance their performance in the most difficult applications. But many off-highway engineers aren't aware that over the past decade the power density and ruggedness of electric actuators has substantially improved, while in hydraulic actuators the improvements have been much smaller or nonexistent.

The power density of hydraulic actuation is largely dependent upon the pressure of their systems, and for safety and cost reasons these pressures have plateaued over the past decade.

On the other hand, the power density of electric motors has substantially increased over the same time frame because of advances in magnetic materials, lead/ball screw efficiency, construction, manufacturing techniques and electronics. One of the most significant benefits is the ability to deliver substantially more power while maintaining high levels of efficiency. Additional improvements have come in the power transmission, largely through gearbox designs that are optimized to the requirements of electric linear actuator applications. As a result, electric actuators provide superior power density in many applications resulting in simplified installation and appreciable vehicle weight savings.

Today, electric linear actuators designed for off highway applications are specifically engineered to withstand harsh environments. Castings use finite element analysis to optimize their load handling capabilities. Electric actuator design has migrated from an approach that uses modular assemblies to one in which the key components are encapsulated in a clamshell that protects them against shock and vibration. Multi-axis vibration testing and analysis prove the ability of electric linear actuators to withstand real-world mechanical loading. Improvements have also come from eliminating the wiring harness previously used to connect to the motor control and instead molding a connector into the housing that the control system cable can be plugged into. This approach provides a better seal and takes the motor connection out of harm's way. All in all, today's electric linear actuators designed for off-highway applications are every bit as rugged as hydraulic actuators.

Myth #2: Electric linear actuators aren't as reliable as hydraulics

The myth that hydraulic actuators are more reliable may also be due to the fact that many engineers are familiar with a previous generation of electric linear actuators that often did experience reliability problems. But electric linear actuators have benefited from dramatically improved reliability of all electronic and electrical products. Consisting solely of a motor, gearbox, lead or ball screw and often a clutch, electric linear actuators are also much simpler than their hydraulic counterparts. Compare this to hydraulic systems that have many more components such as a reservoir, pump, DC motor, motor relay, solenoid valve, check valve, hydraulic cylinder, and push-button station. Based on highly reliable electronic technology and with minimized possible points of failure, the reliability of electric linear actuators has improved in recent years to the point that in the vast majority of applications they will outlive the equipment they are installed on.

Electric linear actuators provide true maintenance-free operation and are therefore much less prone to fail due to lack of maintenance. Maintenance with hydraulic systems begins with changing the fluid and filter on a regular basis and ensuring that the system always has sufficient fluid. Hydraulic fluid is subject to contamination in tough off-highway applications. Contamination causes a ripple effect as it moves through the system and damages multiple components, each of which may need to be repaired or replaced. With multiple axes generally controlled by a single hydraulic system, a problem can affect many areas of the equipment operation. For example, high loads in one axis might reduce circuit pressure and affect other

axes. Another concern is that when a hydraulic system is lost such as in a line rupture, there is no way to manually actuate the affected axes.

In contrast, today's electric linear actuators require zero maintenance - not even lubrication. Electric linear actuators run independently with every axis being powered by a different motor, so a failure in an electric application affects only that single actuator, which makes it much easier to troubleshoot and repair.

To ensure load hold hydraulics require power to the system, and should a hose or valve rupture its ability hold the load is significantly compromised. Actuators, on the other hand, provide indefinite load holding in an un-powered condition, with virtually no drift or back driving. Finally, electric linear actuators can easily be configured with a manual override that can be used if something should go wrong with either the power supply or actuator motor.

Myth #3: Electric linear actuators are more expensive

The idea that electric linear actuators are more expensive probably arises from the notion that each electric axis requires a motor, leadscrew and a gearbox while adding a hydraulic axis only requires a cylinder. But in fact the hydraulic cylinder is only one component of the hydraulic system that is required to support the axis. Valves, hoses, and fittings will also be required and in many cases the existing hydraulic pump will not have capacity to accommodate the new axis.

Actuator economics depend to a significant degree on how many axes are actuated by a particular hydraulic system. Electric linear actuators are usually considerably less expensive in applications where an additional hydraulic pump must be added to handle another axis. As a general rule of thumb, when a hydraulic system operates one, two or three axes of motion, it can generally be replaced with electric linear actuators at a lower cost.

Another factor that figures into the relative cost of electric vs. hydraulic actuators in many agricultural applications is the number of available hydraulic ports. A port is required for each accessory and adding additional ports is expensive because of the need to add a valve, hosing, tubing and connectors, not to mention additional capacity from the charging pump. Electric linear actuators can be used to add accessories without occupying a port. Electric linear actuators also provide advantages for axes that are a long distance from the pump because they eliminate the cost of the materials and labor required to run hose from the pump to the hydraulic cylinder.

The operating cost of electric linear actuators is usually considerably less than hydraulic systems because electric linear actuators only require power when they are actually moving something while even the most efficient hydraulic systems generate continuous losses. The simplicity of electric linear actuators also makes them substantially less expensive to install. And electric linear actuators require zero maintenance as opposed to hydraulic actuators whose fluid and filter needs to be changed at regular intervals.

Myth #4 Electric linear actuators increase design complexity

The idea that electric linear actuators increase the complexity of the design process probably arises from the fact that many off-highway vehicles do not currently use electric linear actuators. So adding electric linear actuators requires working with two types of actuators instead of one. In addition, many off-highway equipment engineers have not had much experience with electric linear actuators. Finally, engineers may be acquainted with the earlier generation of electric linear actuators that required the selection and assembly of various components such as motors, gearboxes and controls.

Today, electric linear actuators have been simplified to the point that they are considerably easier to specify and design than hydraulic actuators. Electric linear actuators are now provided as integrated systems that require nothing more than hooking up two wires and a double-pole double-throw (DPDT) switch.

It takes only three steps to determine the size of an actuator for an application: measure the load, determine the duty cycle and specify stroke and retract length. The precise load on an actuator may not be known because of the effects of intermediate linkages. Loads can be determined with software packages that simulate mechanical systems or by performing measurements with a load cell on the actuator. Electric linear actuators can easily be configured by the manufacturer to fit the requirements of any application by changing gear ratios, leadscrew, motor, and electronic control parameters to predictably affect the key performance variables.

The one-actuator, one-axis principle of electric linear actuators eliminates interactions with other actuators, enabling engineers to focus entirely on the axis they are designing. With hydraulic actuators, on the other hand, engineers need to be concerned about how bleeding off power for the new axis will affect other axes.

When these myths are analyzed, it's clear that electric linear actuators present a superior alternative to hydraulics in many off-road applications. The ruggedness of electric linear actuators has improved in recent years to the point where they are just as durable and reliable as hydraulic actuators. They are also insensitive to issues that can present major concerns with hydraulics, such as contamination or temperature fluctuations. The cost of an electric system depends upon the application and is generally lower than hydraulics in one-, two- and three-axis applications. Finally, today's integrated electric linear actuators are very simple to design into any type of off-road equipment.

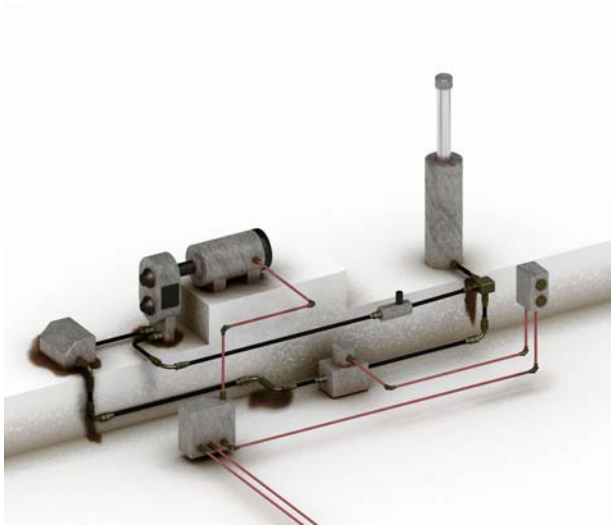

This single acting, uni-directional hydraulic cylinder system is one of the simplest hydraulic solutions available. It consists of eight parts that must be taken into consideration during the design process and installed by the OEM. For bi-directional operation, a more complex and costly bi-directional system would need to be installed.



This simple electric actuator system ensures consistent bi-directional operation, while providing significant additional OEM and end-user benefits. OEM machine builders will benefit from a lower cost, easier to install, higher-performing solution that promises a significant advantage over the competition. End-users will benefit from improved control over critical machine operations, with superior accuracy and zero maintenance over the life of the machine, for significantly increased machine productivity.

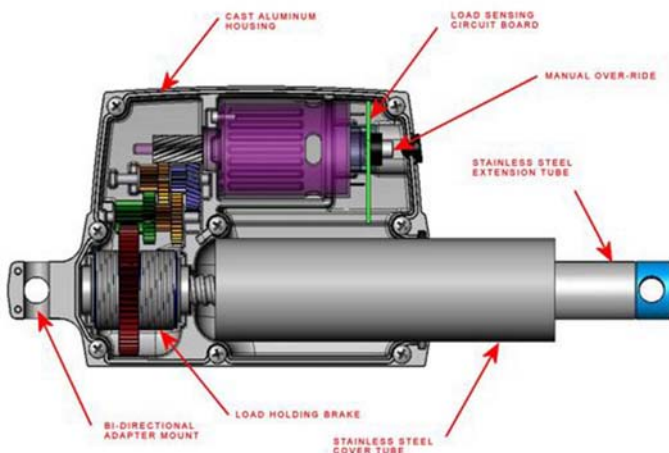

Electric actuator design has migrated from an approach that uses modular assemblies to one in which the key components are encapsulated in a “clamshell” that cradles them against shock and vibration for optimized environmental protection.