

# Electromagnetic Friction Clutches & Brakes

## Flange Mounted Brakes – Type FB

### FB SERIES POWER-ON BRAKES

#### Flange Mounted Brakes – Type FB

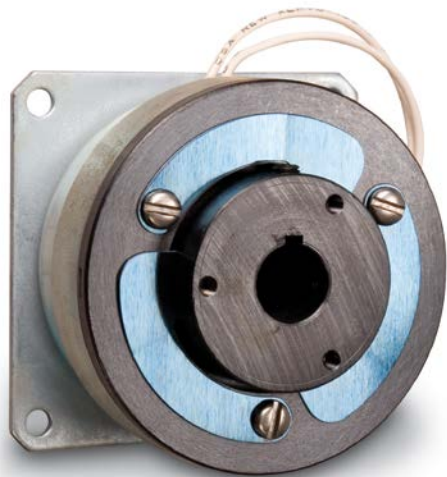

FB series power-on brakes are used to stop or hold a load that is coupled to the armature hub assembly. The armature hub is attached to the load shaft. The field assembly is mounted to a bulkhead that is perpendicular to the shaft.

#### Customer Shall Maintain:

The perpendicularity of the mounting surface with respect to the shaft not to exceed .005 inch (.127mm) T.I.R. at a diameter equal to the bolt circle; concentricity between the brake mounting pilot diameter and the shaft not to exceed .010 inch (.254mm) T.I.R.; initial air gap setting of .005-.020 (.127-.508mm) inches.

#### Model FB08 through FB26

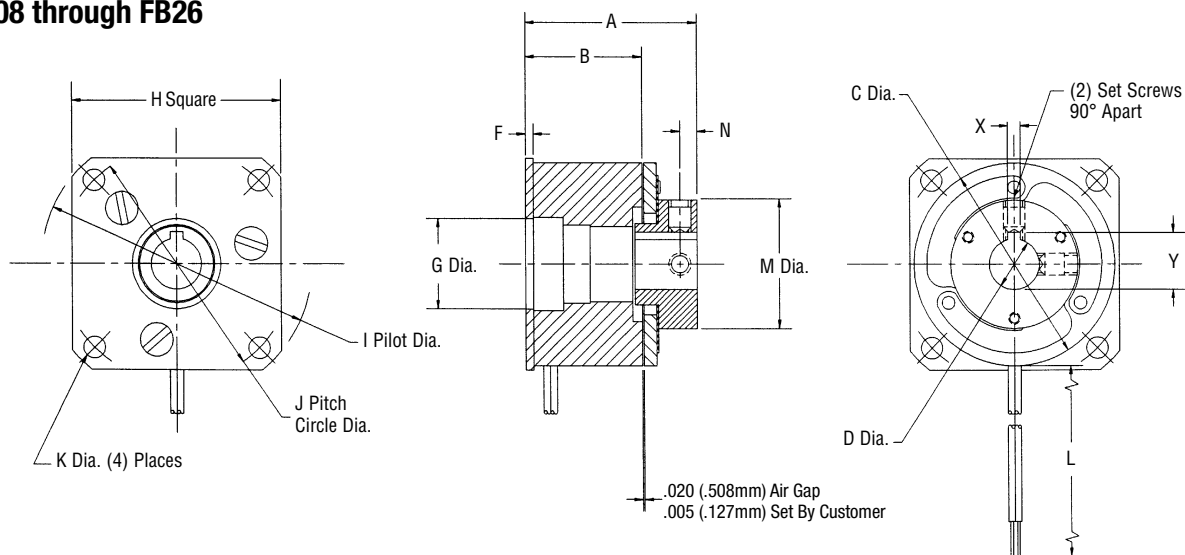

#### Model FB30 and FB42

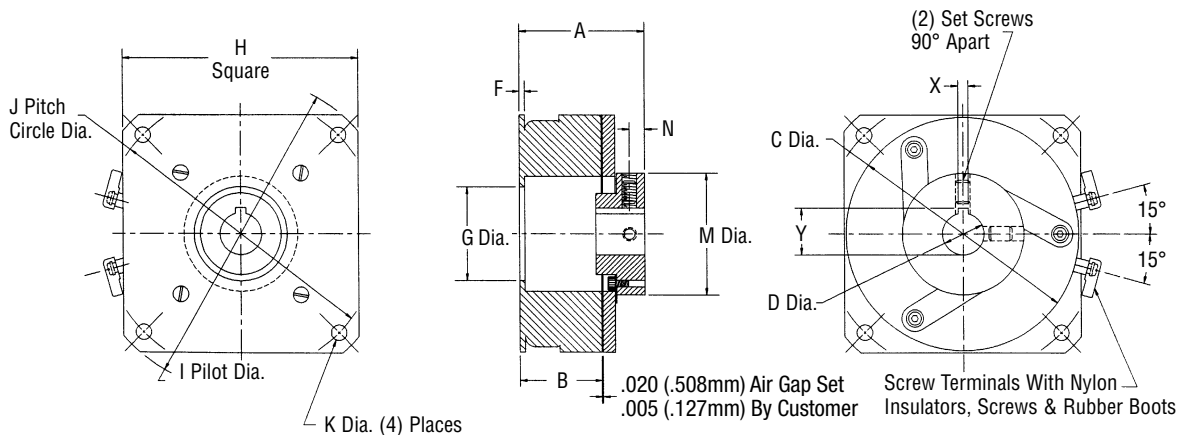

# Electromagnetic Friction Clutches & Brakes

## Flange Mounted Brakes – Type FB Imperial

### Mechanical

MODEL NO.	STATIC TORQUE LB. - IN.	INERTIA LB. - IN. <sup>2</sup>	WEIGHT OZ.
		ARM & HUB	
FB08	2.5	.0011	2.0
FB11	6	.0024	3.2
FB15	10	.026	3.8
FB17	15	.031	11
FB19	25	.042	12
FB22	50	.070	20
FB26	80	.320	28
FB30	125	.561	35
FB42	250	2.30	60

### Electrical

MODEL NO.	90 VDC		24 VDC		12 VDC	
	AMPS	OHMS	AMPS	OHMS	AMPS	OHMS
FB08	.049	1970	.117	205	.246	48.8
FB11	.047	1930	.198	121	.447	26.8
FB15	.042	2150	.183	132	.380	31.6
FB17	.066	1369	.289	83	.561	21.4
FB19	.074	1213	.322	74.4	.574	20.9
FB22	.079	1140	.322	74.6	.628	19.1
FB26	.092	980	.374	64.2	.760	15.8
FB30	.091	988	.378	65.3	.729	16.5
FB42	.124	722	.468	51.2	.934	12.84

Lead wire is UL recognized style 1213, 1015 or 1430, 22 gage.  
 Insulation is .050 O.D. on 08, 11, 15 units; .064 or .095 O.D. on all other units.

### Dimensions

MODEL NO.	A MAX.	B NOM.	C MAX.	D NOM.	F MAX.	G ±.001	H MAX.	I ±.001	J NOM.	K MIN.	L ±.500	HUB KEYWAY		M MAX.	N NOM.	
												BORE	KEYWAY			
													X			Y
FB08	.885	.634	.905	1/8 3/16 1/4	.034	N.A.	.980	1.1995	1.030	.094	12.00	N.A.	SET SCREWS ONLY	.500	.070	
FB11	.954	.650	1.160	3/16 1/4 5/16	.052	N.A.	1.230	1.498	1.312	.123	12.00	N.A.	SET SCREWS ONLY	.687	.093	
FB15	1.304	.867	1.500	1/4 5/16 3/8	.063	N.A.	1.567	1.999	1.750	.156	12.00	N.A.	SET SCREWS ONLY	.960	.125	
FB17	1.269	.848	1.780	1/4 5/16 3/8	.064	.751	1.943	2.436	2.125	.186	12.00	1/4 5/16 3/8	.0625 - .0655 .0625 - .0655 .094 - .097	.285 - .290 .347 - .352 .417 - .427	1.190	.115
FB19	1.330	.901	2.000	5/16 3/8 1/2	.062	.751	1.943	2.436	2.125	.186	12.00	5/16 3/8 1/2	.0625 - .0655 .094 - .097 .125 - .128	.347 - .352 .417 - .427 .560 - .567	1.190	.115
FB22	1.757	1.173	2.260	3/8 1/2	.096	1.001	2.322	2.873	2.500	.160	18.00	3/8 1/2	.094 - .097 .125 - .128	.417 - .427 .560 - .567	1.005	.115
FB26	1.815	1.300	2.645	3/8 1/2 5/8	.080	1.062	2.630	3.499	3.125	.182	18.00	3/8 1/2 5/8	.094 - .097 .125 - .128 .1885 - .1905	.417 - .427 .560 - .567 .709 - .716	1.440	.150
FB30	1.900	1.310	3.268	1/2 5/8 3/4	.097	1.751	3.200	4.186	3.750	.182	SCREW TERMINALS	1/2 5/8 3/4	.125 - .128 .1885 - .1905 .1885 - .1905	.560 - .567 .709 - .716 .836 - .844	1.825	.150
FB42	2.280	1.490	4.270	1/2 5/8 3/4 7/8 1	.097	1.875	4.255	5.624	5.000	.276	SCREW TERMINALS	1/2 5/8 3/4 7/8 1	.125 - .128 .1885 - .1905 .1885 - .1905 .1885 - .1905 .251 - .253	.560 - .567 .709 - .716 .836 - .844 .962 - .970 1.113 - 1.121	2.195	.250

### Notes:

- 08 units have set screws 120° apart.

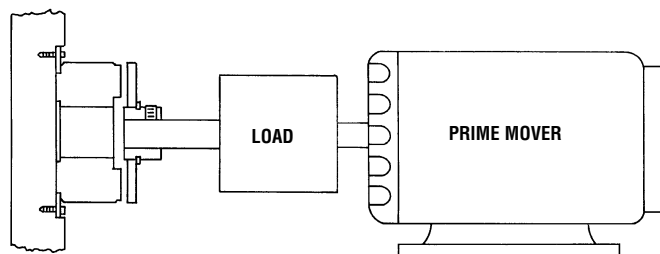

See page 4 for Ordering Information

# Electromagnetic Friction Clutches & Brakes

## Flange Mounted Brakes – Type FB Metric

### Mechanical

MODEL NO.	STATIC TORQUE N-m	INERTIA	WEIGHT kg
		kg - cm <sup>2</sup> ARM & HUB	
FB08	.28	.003	.057
FB11	.68	.007	.091
FB15	1.13	.076	.108
FB17	1.70	.091	.312
FB19	2.83	.123	.340
FB22	5.65	.205	.567
FB26	9.04	.936	.794
FB30	14.12	1.642	.992
FB42	28.24	6.731	1.70

### Electrical

MODEL NO.	90 VDC		24 VDC		12 VDC	
	AMPS	OHMS	AMPS	OHMS	AMPS	OHMS
FB08	.049	1970	.117	205	.246	48.8
FB11	.047	1930	.198	121	.447	26.8
FB15	.042	2150	.183	132	.380	31.6
FB17	.066	1369	.289	83	.561	21.4
FB19	.074	1213	.322	74.4	.574	20.9
FB22	.079	1140	.322	74.6	.628	19.1
FB26	.092	980	.374	64.2	.760	15.8
FB30	.091	988	.378	65.3	.729	16.5
FB42	.124	722	.468	51.2	.934	12.84

Lead wire is UL recognized style 1213, 1015 or 1430, 22 gage.

Insulation is .127 mm O.D. on 08, 11, 15 units; 1.63 mm or 2.41 mm O.D. on all other units.

### Dimensions

MODEL NO.	A MAX.	B NOM.	C MAX.	D NOM.	E NOM.	F MAX.	G ±.025	H MAX.	I ±.025	J NOM.	K MIN.	L ±12.7	HUB KEYWAY		M MAX.	N NOM.	
													BORE	KEYWAY			
														X			Y
FB08	22.479	16.104	22.987	5H9	14.529	0.864	N.A.	24.892	30.4673	26.162	2.388	304.800	N.A.	SET SCREWS ONLY	12.700	1.778	
FB11	24.740	16.510	29.464	6H9 8H9	15.138	1.321	N.A.	31.242	38.049	33.325	3.124	304.800	N.A.	SET SCREWS ONLY	17.450	2.362	
FB15	33.122	22.022	38.100	8H9 10H9	20.371	1.600	N.A.	39.802	50.775	44.450	3.962	304.800	N.A.	SET SCREWS ONLY	24.384	3.175	
FB17	32.233	21.539	45.212	8H9 10H9	18.847	1.626	19.075	49.352	61.874	53.975	4.724	304.800	8H9 10H9	1.988-2.060 2.988-3.060	9.00-9.10 11.40-11.50	30.226	2.921
FB19	33.782	22.885	50.800	10H9	19.710	1.575	19.075	49.352	61.874	53.975	4.724	304.800	10H9	2.988-3.060	11.40-11.50	30.226	2.921
FB22	44.628	29.794	57.404	10H9	25.984	2.438	25.425	58.979	72.974	63.500	4.064	457.200	10H9	2.988-3.060	11.40-11.50	25.527	2.921
FB26	46.101	33.020	67.183	10H9 15H9	29.210	2.032	26.975	66.802	88.875	79.375	4.623	457.200	10H9 15H9	2.988-3.060 4.985-5.078	11.40-11.50 17.30-17.40	36.576	3.810
FB30	48.260	33.274	83.007	15H9 17H9	29.464	2.464	44.475	81.280	106.324	95.250	4.623	SCREW TERMINALS	15H9 17H9	4.985-5.078 4.985-5.078	17.30-17.40 19.30-19.40	46.355	3.810
FB42	57.912	37.846	108.458	17H9 20H9 25H9	N.A.	2.464	47.625	108.077	142.850	127.000	7.010	SCREW TERMINALS	17H9 20H9 25H9	4.985-5.078 5.985-6.078 7.982-8.098	19.30-19.40 22.80-22.90 28.30-28.50	55.753	6.350

### Notes:

- 08 units have set screws 120° apart.

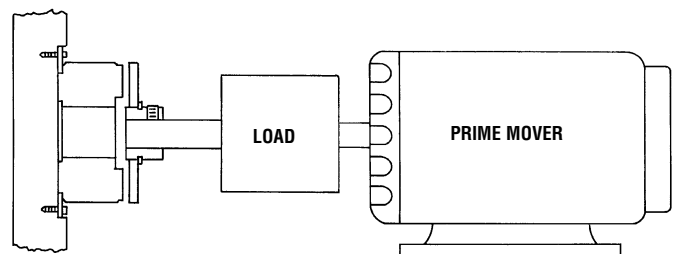

See page 4 for Ordering Information